

# Novosibirsk ERL facility

**G.N. Kulipanov and NovoFEL team**

*Budker INP, Novosibirsk, Russia*



The 59th ICFA Advanced Beam Dynamics Workshop on Energy Recovery Linacs

*CERN, 18-23 June 2017*

# NovoFEL Team

N.A. Vinokurov, V.M. Borin, I.V. Davidyuk, E.N.Dementyev,  
V.I. Dorokhov, Ya.V.Getmanov, B.A.Knyazev, E.I.Kolobanov,  
A.A.Kondakov, E.V.Kozyrev, V.V.Kubarev, G.N.Kulipanov,  
I.V.Kuptsov, G.Ya.Kurkin, O.I. Meshkov, S.V.Motygin,  
V.N.Osipov, V.M.Petrov, L.E.Medvedev, V.K.Ovchar,  
V.M.Popik, V.V.Repkov, T.V.Salikova, M.A.Scheglov,  
I.K.Sedlyarov, S.S.Serednyakov, O.A.Shevchenko,  
A.N.Skrinsky, S.V.Tararyshkin, V.G.Tcheskidov, A.G.  
Tribendis, V.N. Volkov.



## Later the project was modified, the base lines kept:

- A four-turn normal conductance linac with energy recovery;
- Low RF cavities (180 MHz)
- A grid-controlled DC gun with  $Q \sim 1\text{nC}$ ,  $t = 1\text{nsec}$ , and  $f_{\text{rep}} = 10\text{kHz} \div 22.5\text{MHz}$ ;
- The ERL can operate in three modes, providing an electron beam for the three different FELs, from  $5\ \mu\text{m}$  up to  $240\ \mu\text{m}$

## Advantages of the low frequency (180 MHz) RF system

- High threshold currents for instabilities
- Operation with long electron bunches (for narrow FEL linewidth)
- Large longitudinal acceptance (good for operation with large energy spread of used beam)
- Relaxed tolerances for orbit lengths and longitudinal dispersion



- Low RF frequency (180 MHz) allows to use normal-conducting RF

Advantage: high beam current.

Disadvantage: high RF power consumption.

Indeed, the characteristic stability parameter is

$$\frac{P_{beam}}{P_{RF}} = \frac{I_{beam} U}{U^2 / (2R)} = \frac{2I_{beam} R}{U} = \frac{Q I_{beam} 2(R/Q)}{U} \sim \frac{Q I_{beam}}{10\text{kA}}$$

Therefore, the “critical” beam current is

$$I_{beam\ cr} = \frac{U}{2R} = \frac{U}{2Q(R/Q)} \sim \frac{10\text{kA}}{Q}$$

- Construction and commissioning four track ERL was divided on three stages;
- The first stage of Novosibirsk high power free electron laser (NovoFEL) working in spectral range  $(90 \div 240) \mu\text{m}$ , based on one track energy recovery linac (ERL) with energy 12 MeV, was commissioned in 2003.
- The second stage of NovoFEL working in spectral range  $(35 \div 80) \mu\text{m}$ , based on two track energy recovery linac with energy 22 MeV, was commissioned in 2009.
- The third stage of NovoFEL working in spectral range  $(8 \div 15) \mu\text{m}$ , based on four track energy recovery linac with energy 42 MeV, was commissioned in 2015.

## 2. Status of NovoFEL - First stage

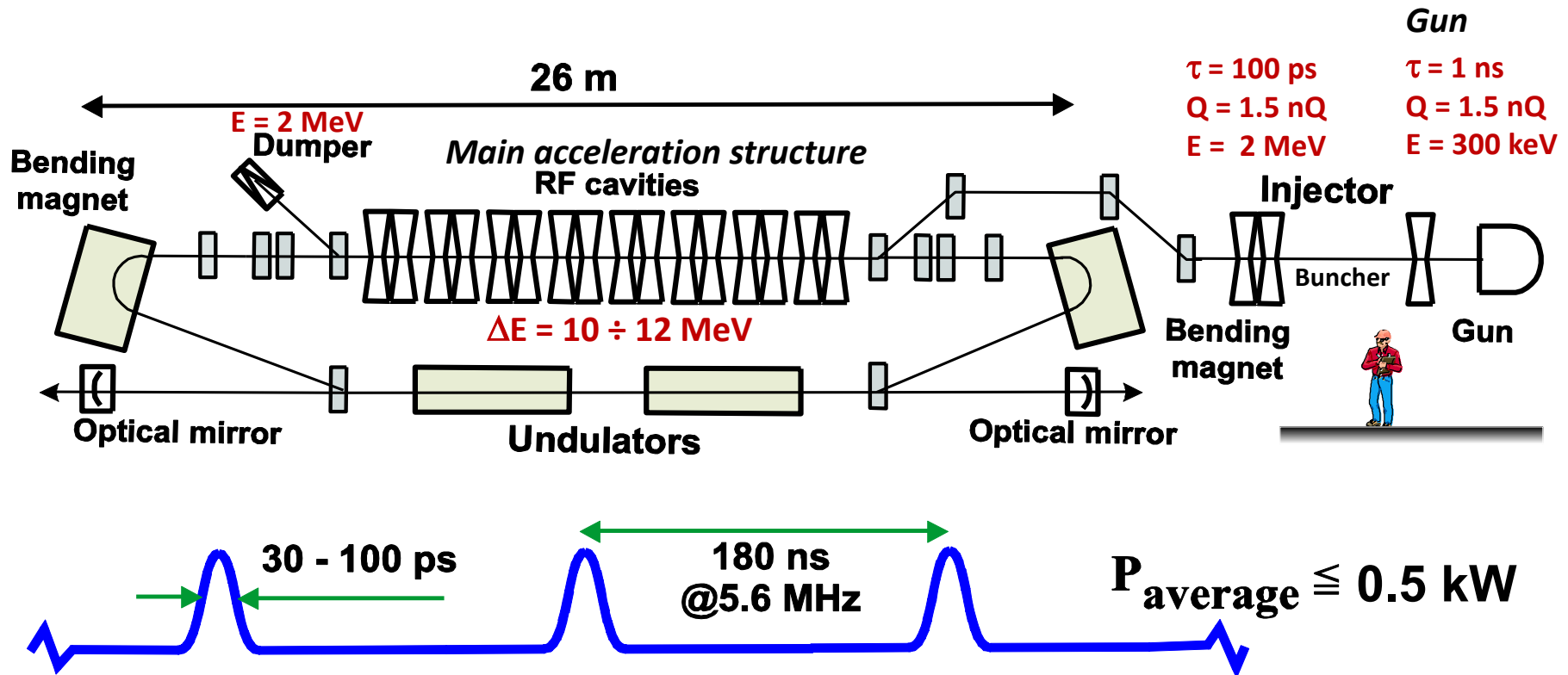

Electron beam from the gun passes through the buncher (a bunching RF cavity), drift section, 2 MeV accelerating cavities, the main accelerating structure and the undulator, where a fraction of its energy is converted to radiation.

After that, the beam returns to the main accelerating structure in a decelerating RF phase, decreases its energy to its injection value (2 MeV) and is absorbed in the beam dump.

# Main linac

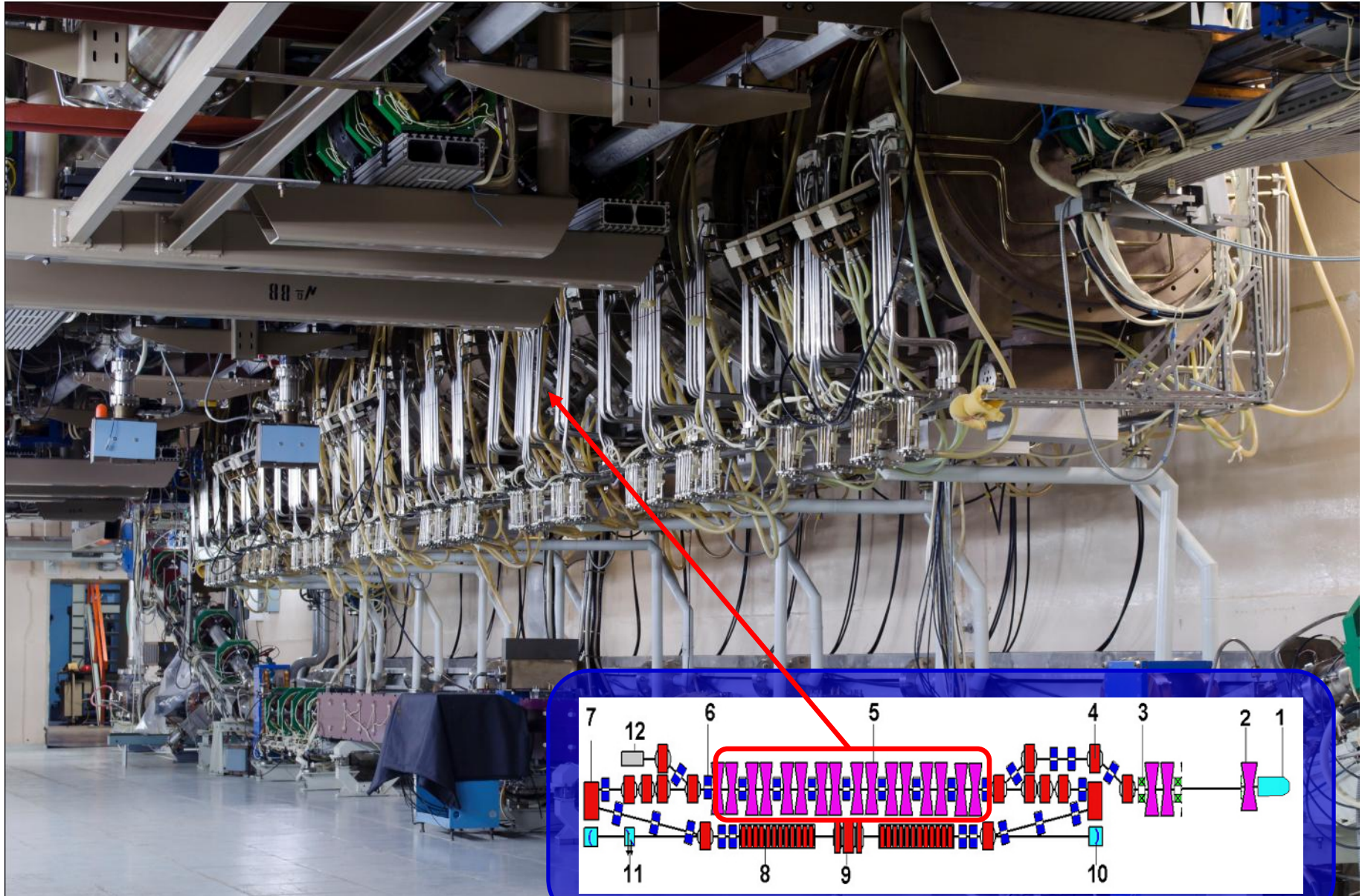



# RF cavities of main linac

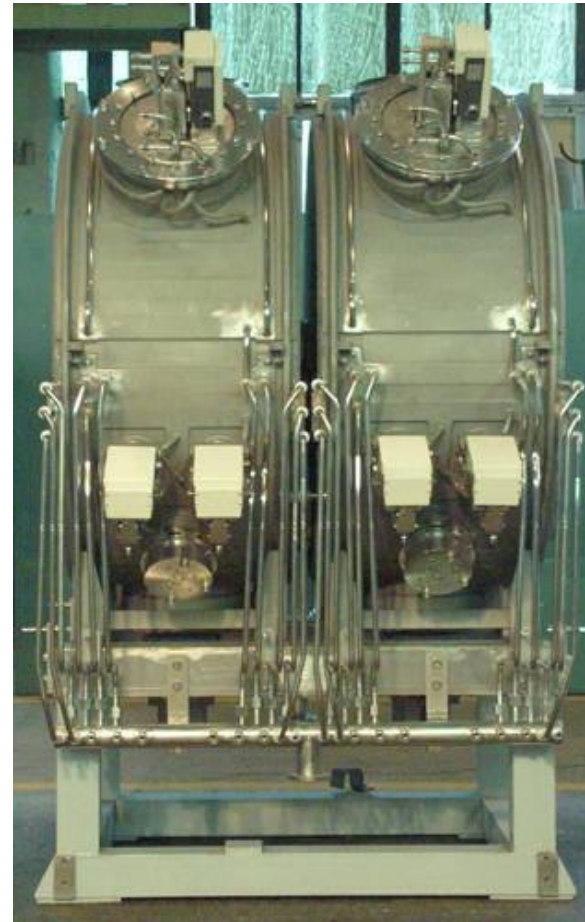
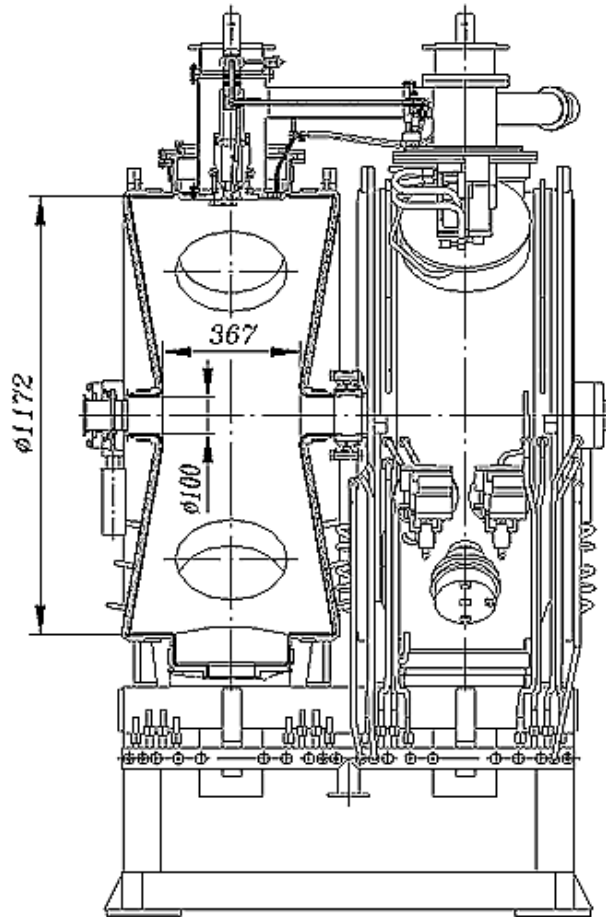

$$F_0 = 180 \text{ MHz}, \quad \Delta f_0 = 320 \text{ kHz}, \quad U_{\text{max}} = 950 \text{ kV},$$

$$U_{\text{eff}} = 850 \text{ kV}, \quad P_{\text{dis}} = 85 \text{ kW}$$

# RF power amplifier



Frequency, MHz	180.4
Power, MW	2 x 0.6



# RF waveguides and feeders



### **3. Second and third stages of NovoFEL design and commissioning**

Novosibirsk energy recovery linac has rather complicated magnetic system. First stage of NovoFEL with 12-MeV electron energy lies in vertical plane.

Other four orbits lie in the horizontal plane.

The beam is directed to these orbits by switching on of two round magnets. In this case electrons pass four times through acceleration RF cavities, obtaining 43-MeV energy. Then, (at the fourth orbit) the beam is used in FEL and decelerated four times.



# NovoFEL Accelerator Design and status

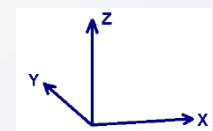
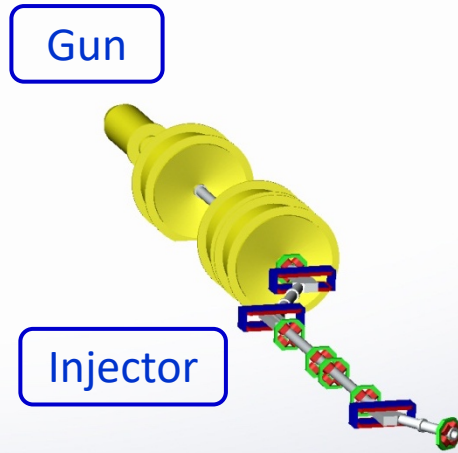

# NovoFEL Accelerator Design and status

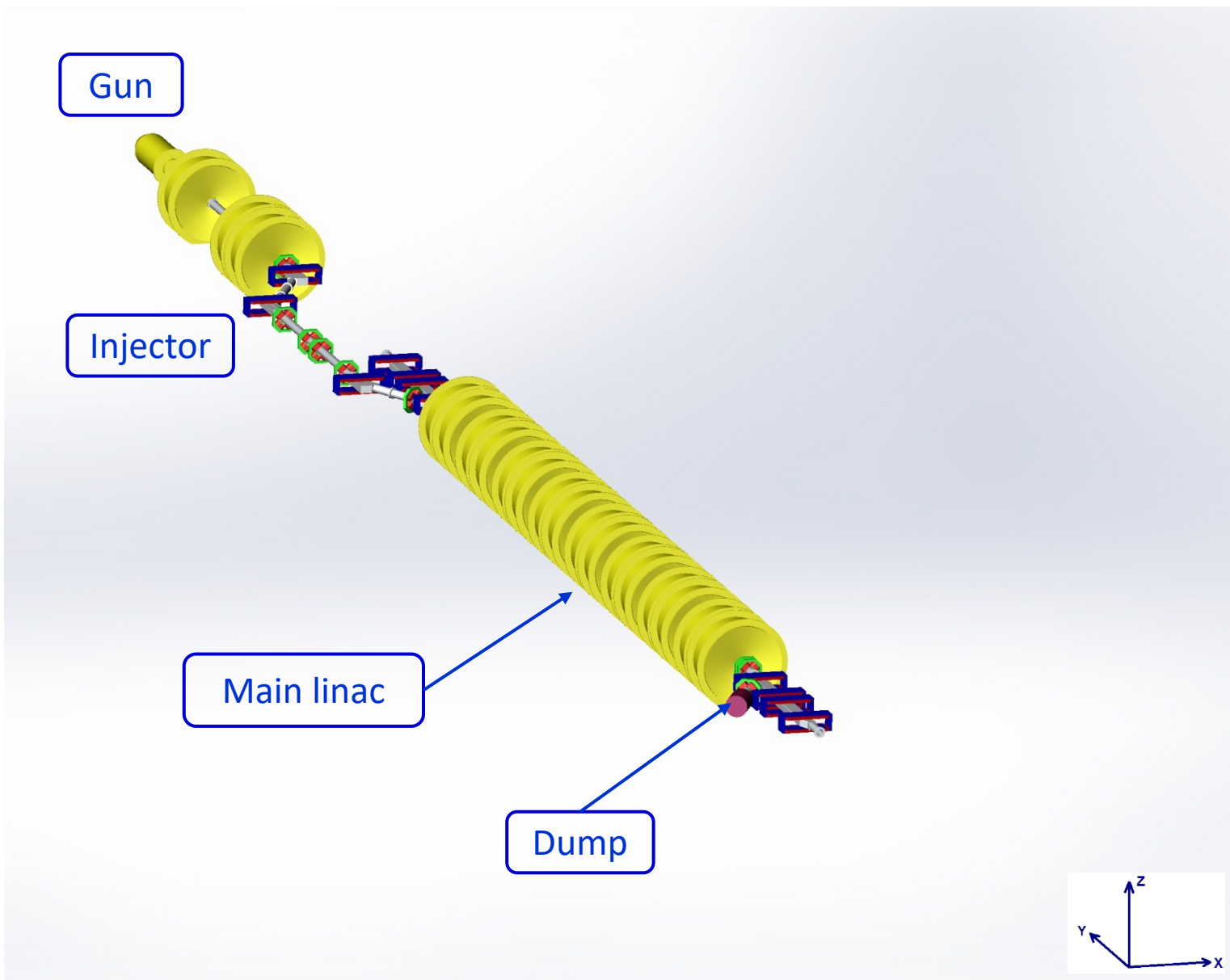

# NovoFEL Accelerator Design and status

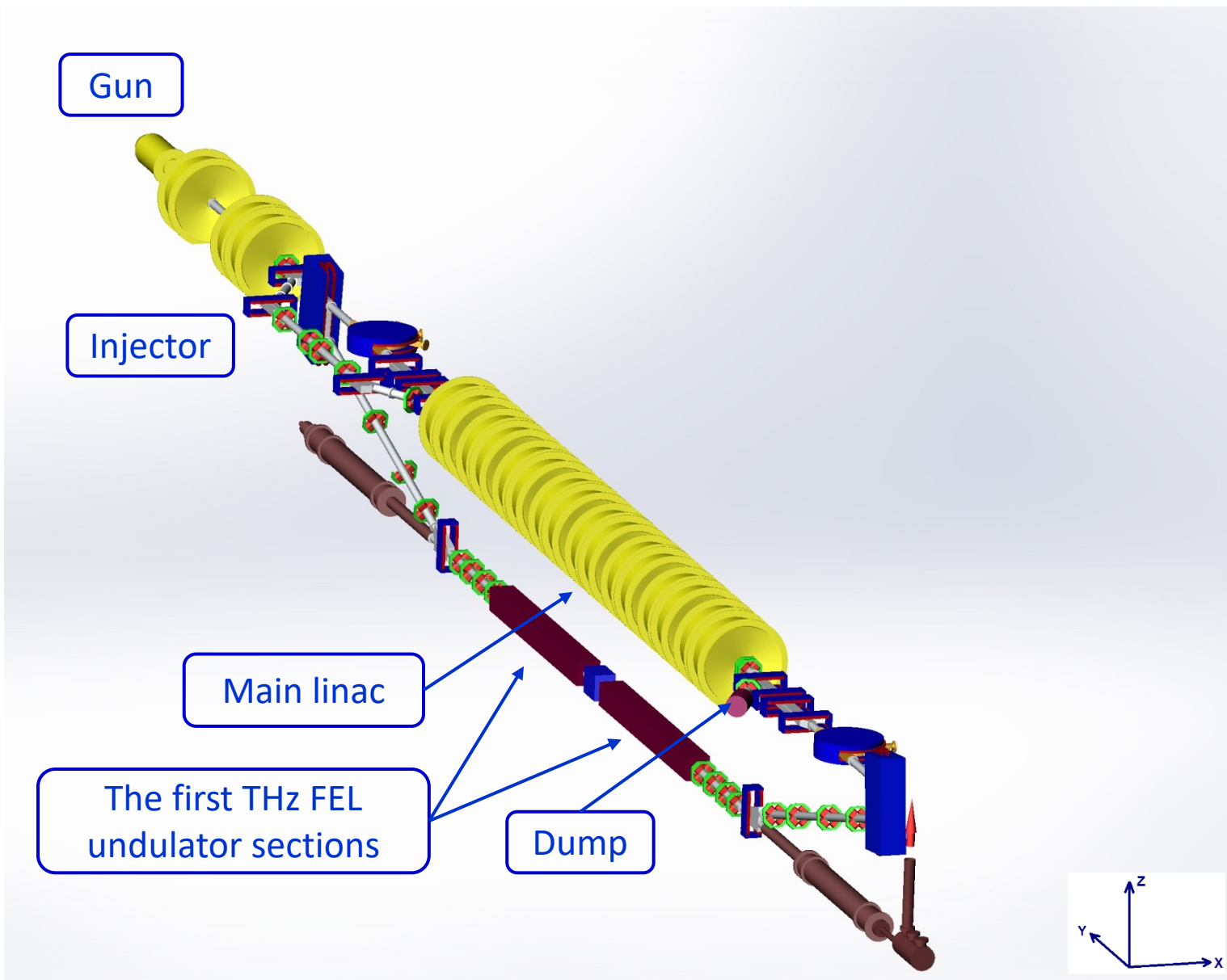

# NovoFEL Accelerator Design and status

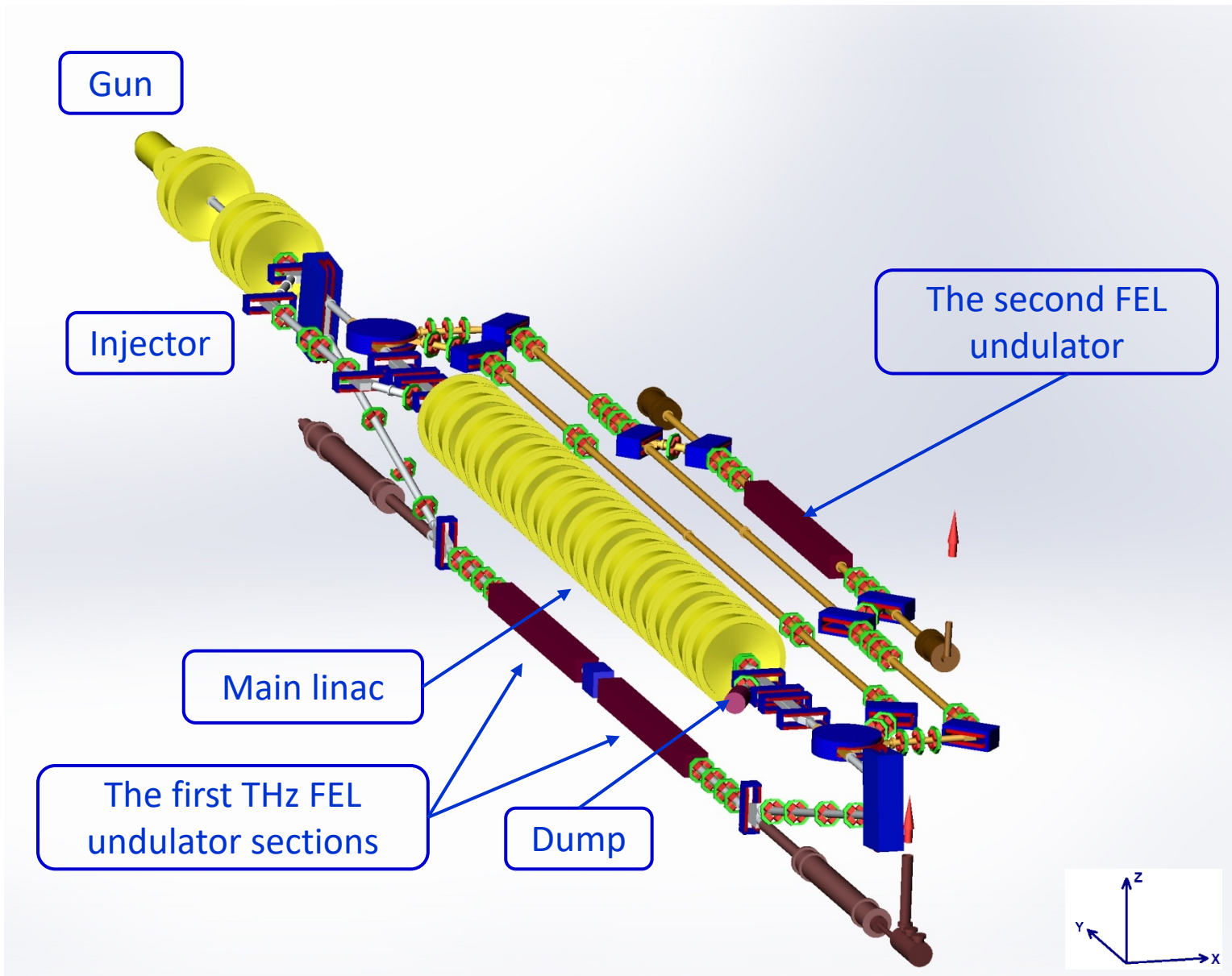

# NovoFEL Accelerator Design and status

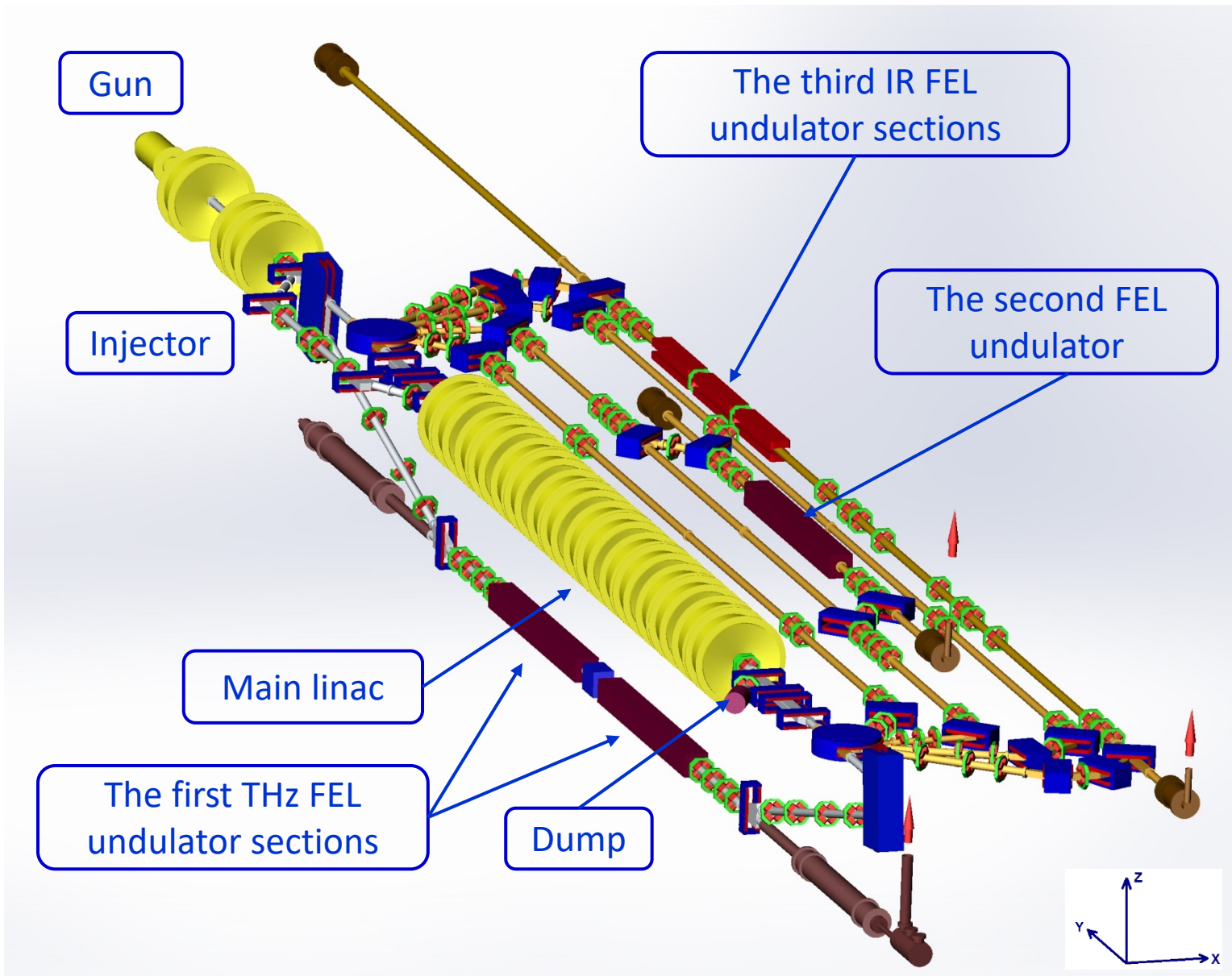

# Second and third stages beamlines

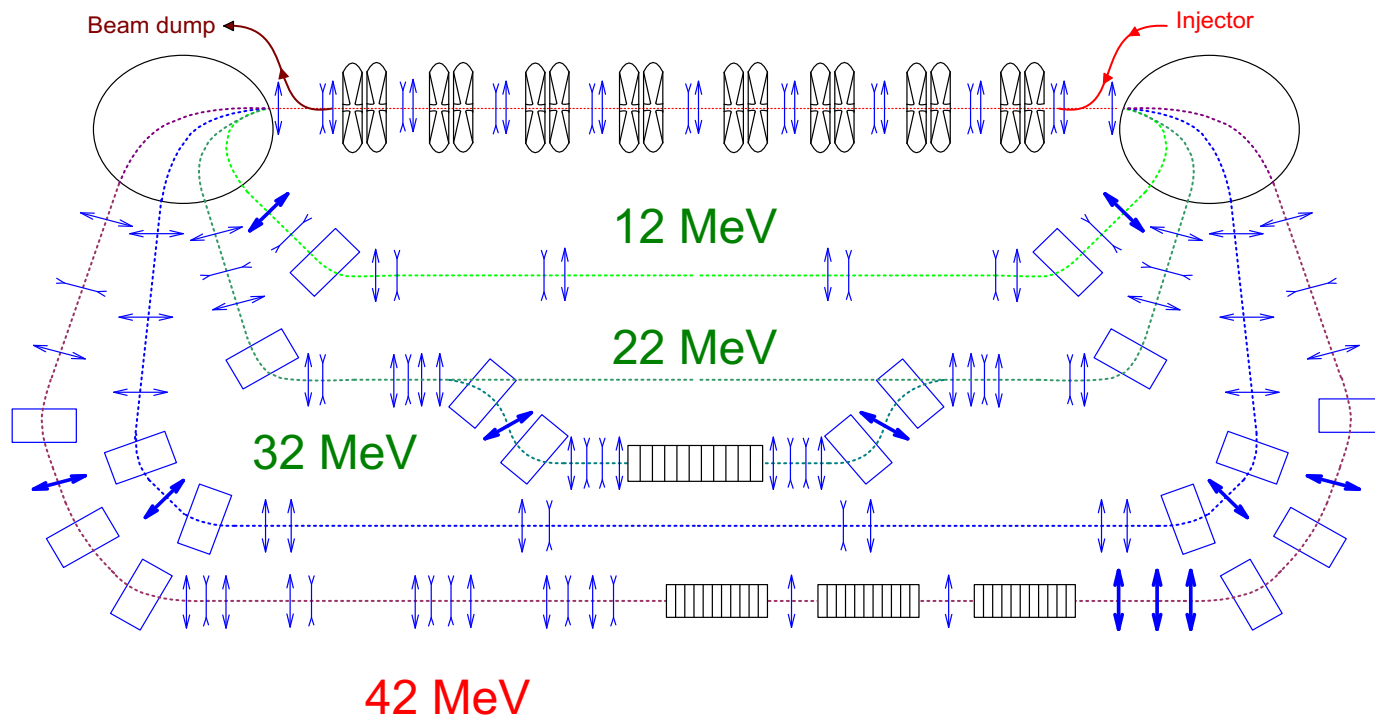

*(horizontal plane)*



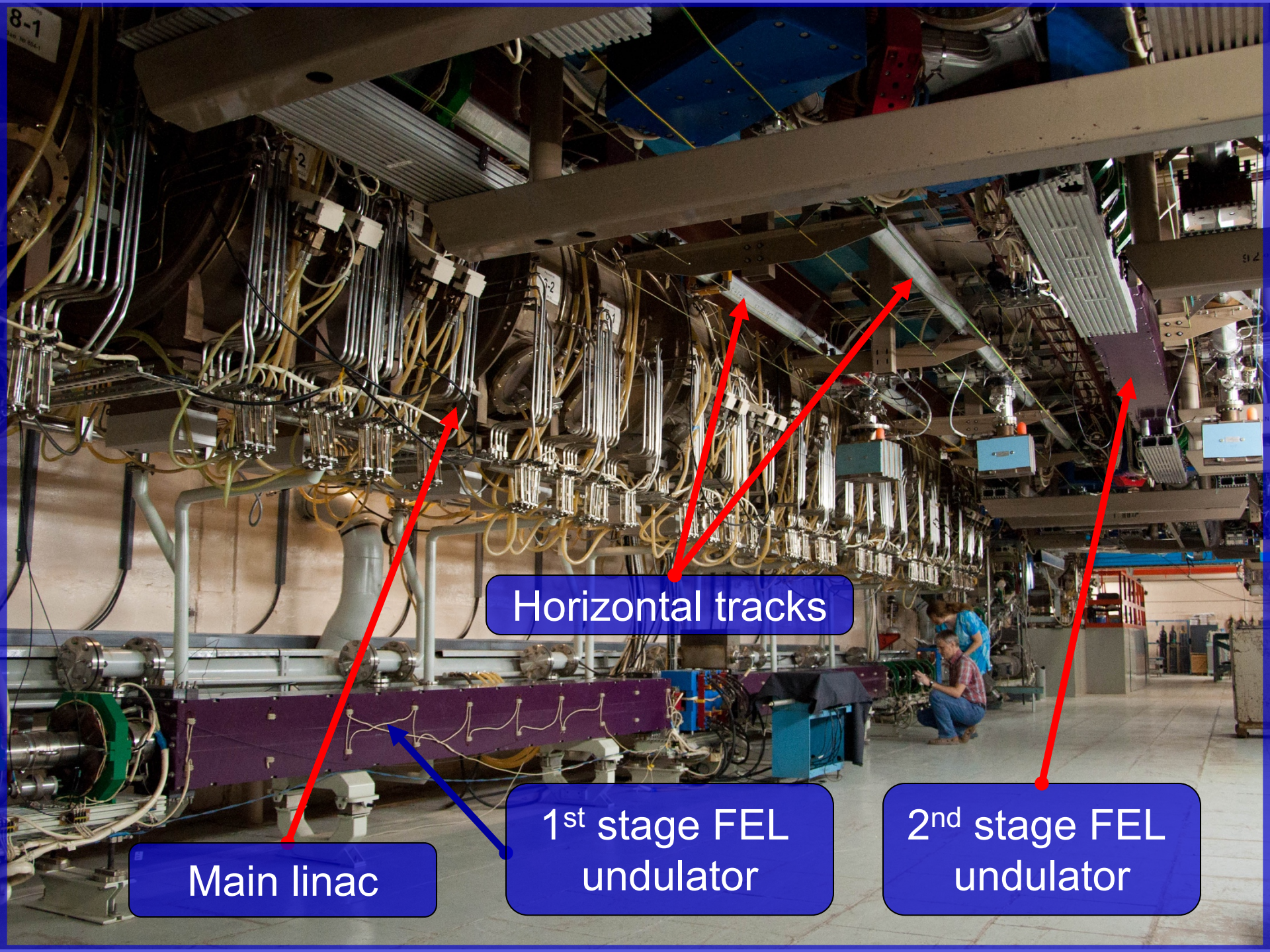

8-1

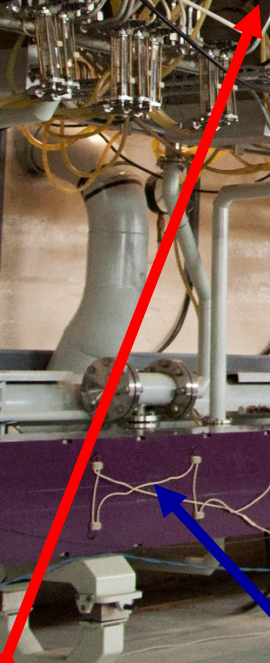

Main linac

Horizontal tracks

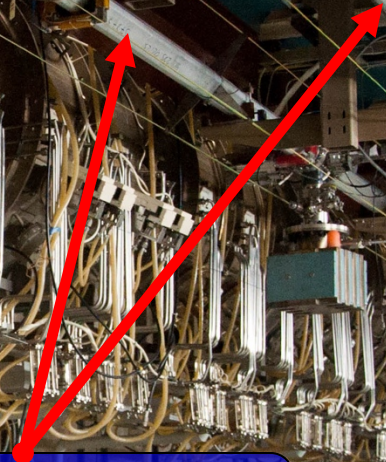

1<sup>st</sup> stage FEL undulator

2<sup>nd</sup> stage FEL undulator





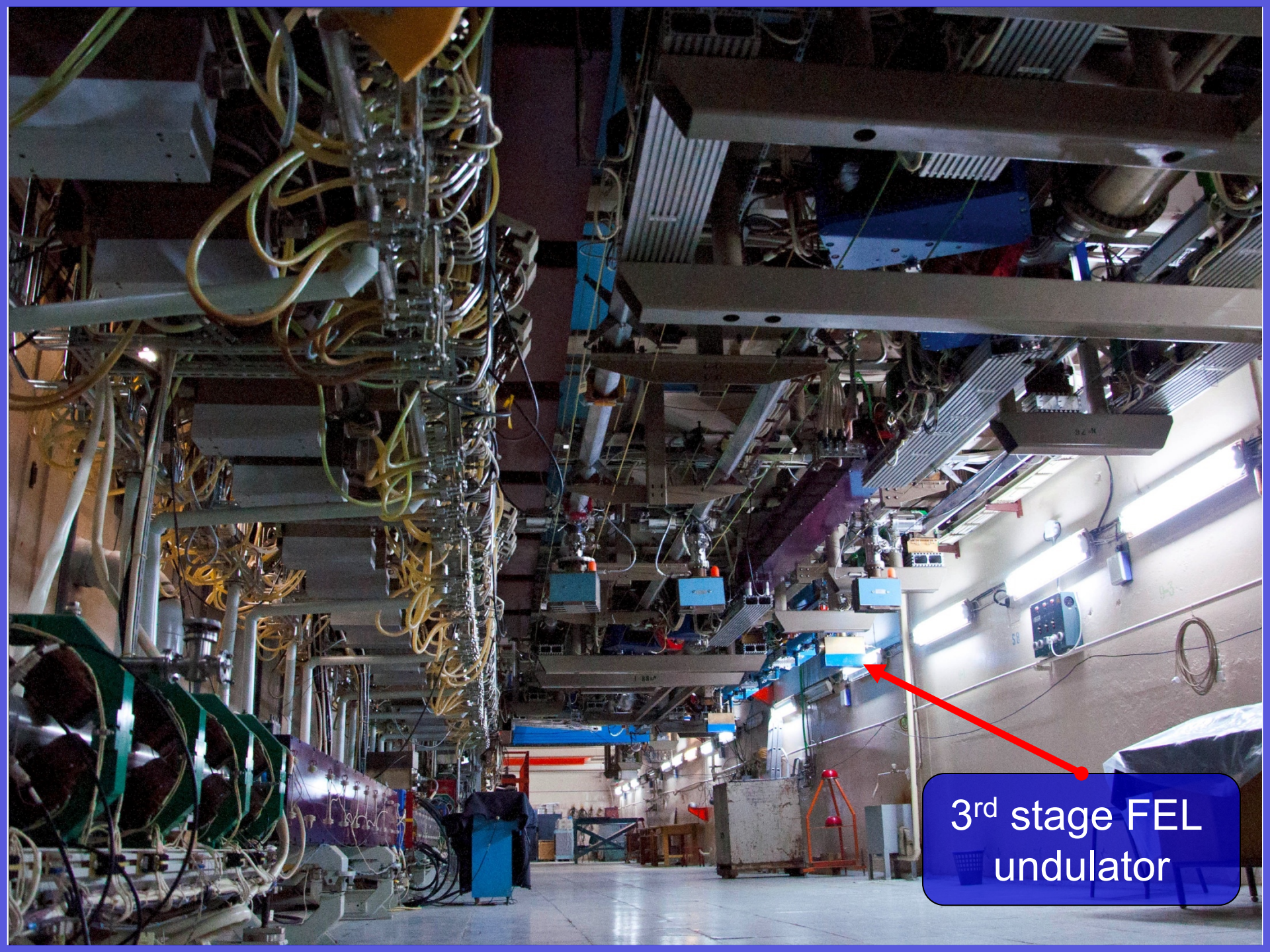

3<sup>rd</sup> stage FEL undulator



## Electron beam and radiation parameters (1)

	1 <sup>st</sup> E=12 MeV			2 <sup>nd</sup> E=22 MeV		3 <sup>rd</sup> E=42 MeV	
	lasing	working	max	lasing	max	lasing	max
Current, mA	5.5	11	30	7.0	7.5	3.0	5
Rep. rate, MHz	5.6	11.2	22.4	7.52	7.52	3.76	5.64
Q nQ	1	1	1.4	0.9		0.8	
P, W	300	500	1000	500		100	

## Electron beam and radiation parameters (2)

	1 <sup>st</sup>	2 <sup>nd</sup>	3 <sup>rd</sup>	
Energy, MeV	12	22	<b>42</b>	46
Current, mA	30	7.5	<b>5</b>	50
Wavelength, $\mu\text{m}$	90-240	40-90	<b>8-11</b>	5-20
Radiation power, kW	0.5	0.5	<b>0.1</b>	5
Electron efficiency, %	0.6	0.3	<b>0.2</b>	0.5

## 4. Nearest and far future plans

- Install optical (SR) diagnostics of electron beam parameters
- Install undulator with variation of period
- Install RF gun
- Improve x-ray and neutron radiation shielding

# RF Gun Test Setup

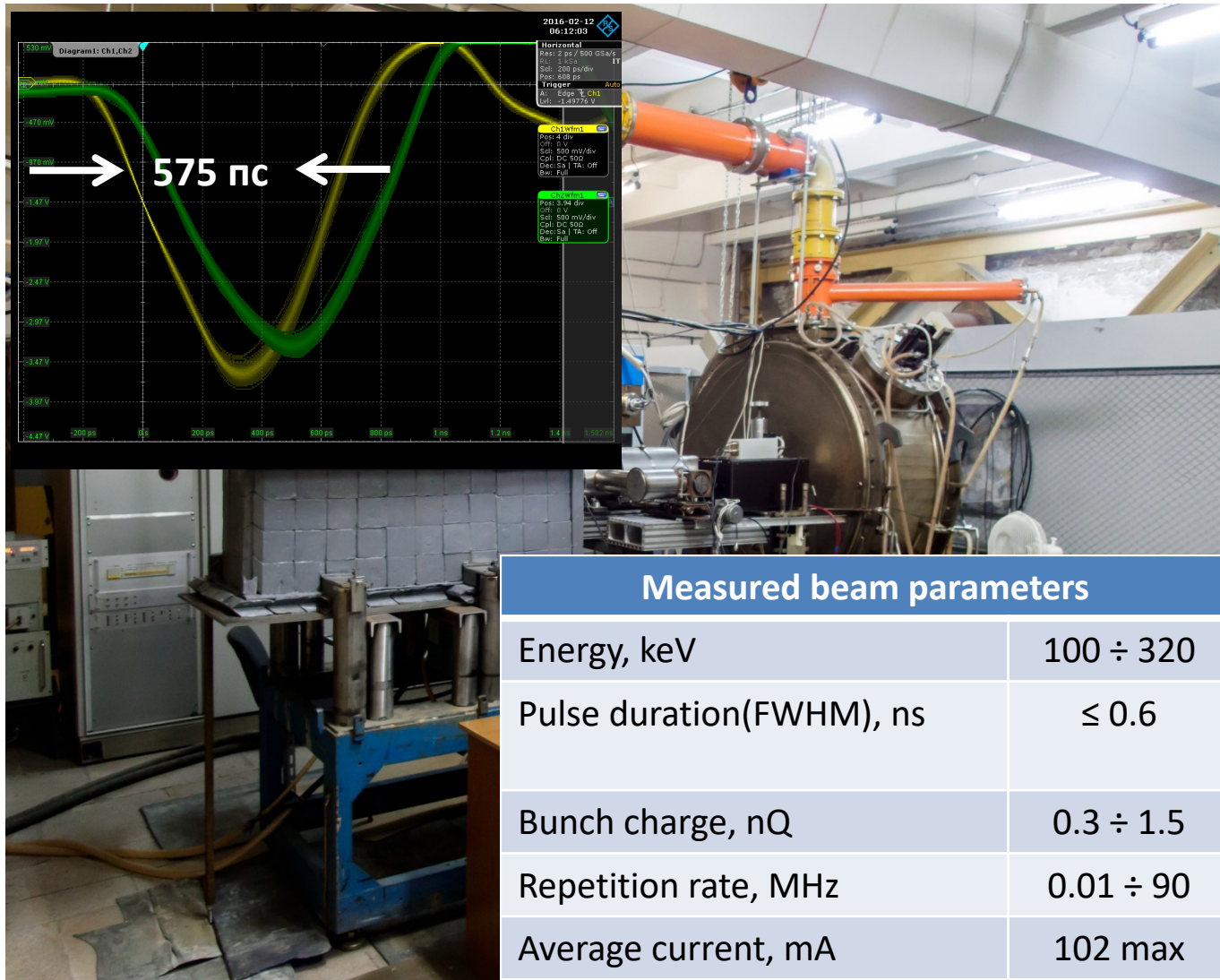

Vladimir N. Volkov CW 100 mA Electron RF Gun for Novosibirsk ERL FEL  
(RUPAC2016)

<http://accelconf.web.cern.ch/AccelConf/rupac2016/papers/tucamh02.pdf>

# RF Gun Installation Layout

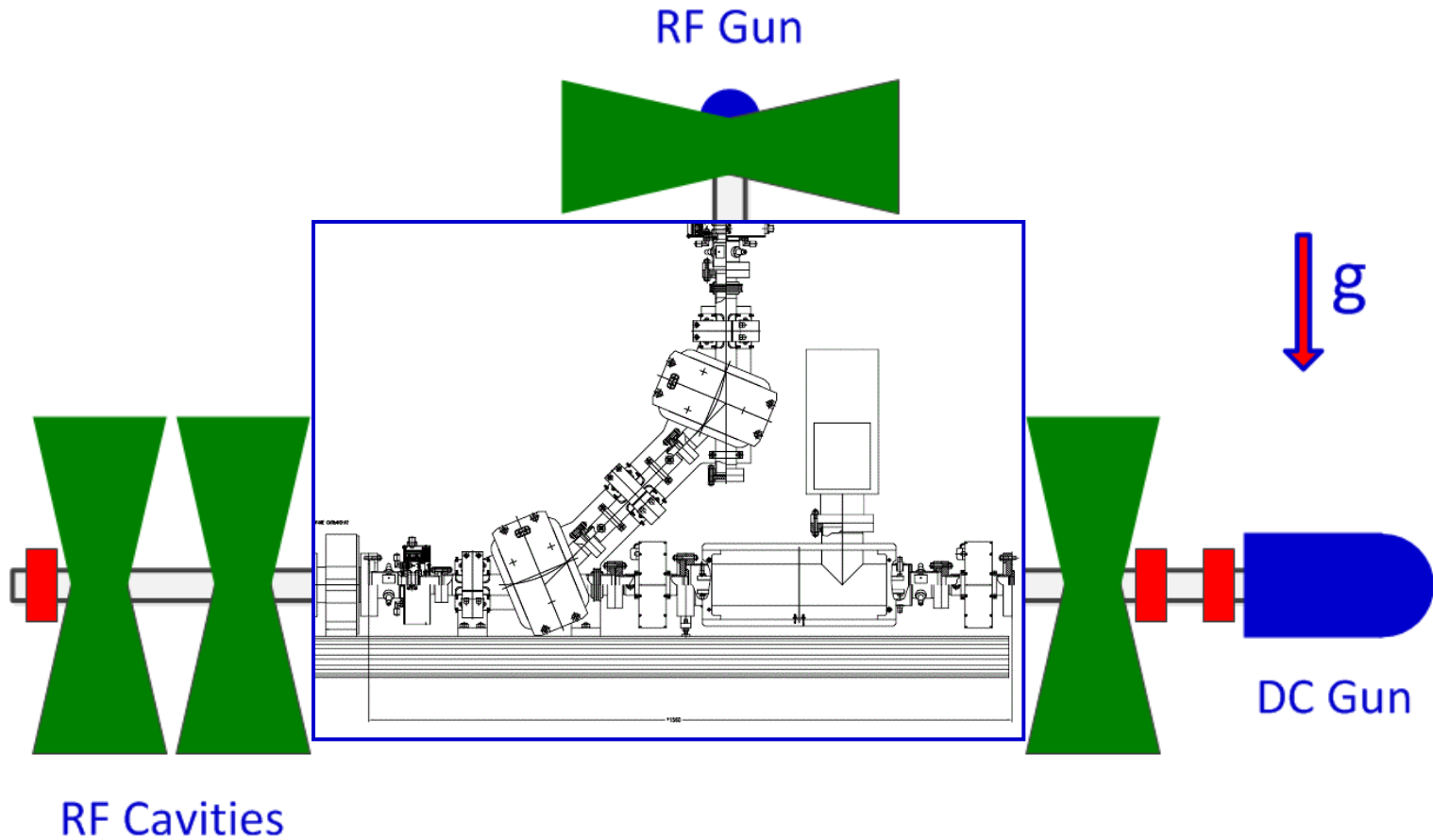

# Undulator with variation of period

One of the main FEL advantages is the ability to adjust the wavelength

$$\lambda = \lambda_u \frac{1}{2\gamma^2} \left( 1 + \frac{K^2}{2} \right)$$

Variation of magnetic field

$$\lambda_u = 12 \text{ cm}$$

$$\lambda_u = 6 \text{ cm}$$

Electromagnetic undulator

Variable gap undulator

$$K \sim 0 \dots 1.5$$

$$K \sim 0.4 \dots 2.5$$

Variation of beam energy

$$E1 \sim 10 \dots 13 \text{ MeV}$$

$$E2 \sim 20 \dots 24 \text{ MeV}$$

$$E3 \sim 40 \dots 46 \text{ MeV}$$

Variation of undulator period  
(N. Vinokurov)

$$K \sim 0.42 \dots 1.79$$

$$\lambda_u \sim 4.8 \dots 9.6 \text{ cm}$$

Variable period undulator



# Variable period undulator at magnetic measurements



# Optical diagnostic of electron beam parameters

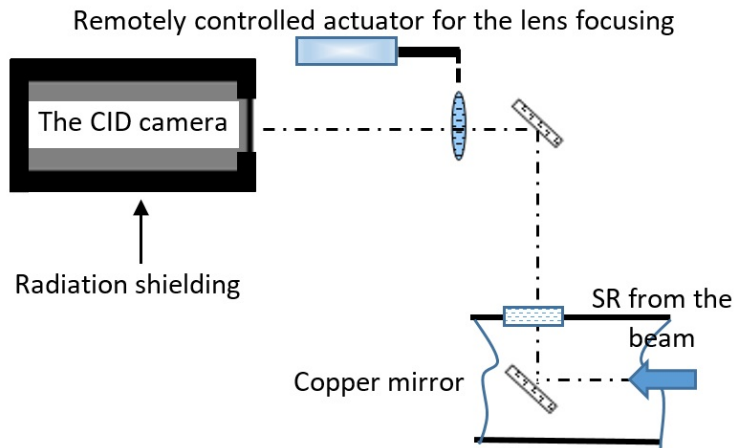

Layout of the diagnostics for acquisition of the transverse profile of the beam

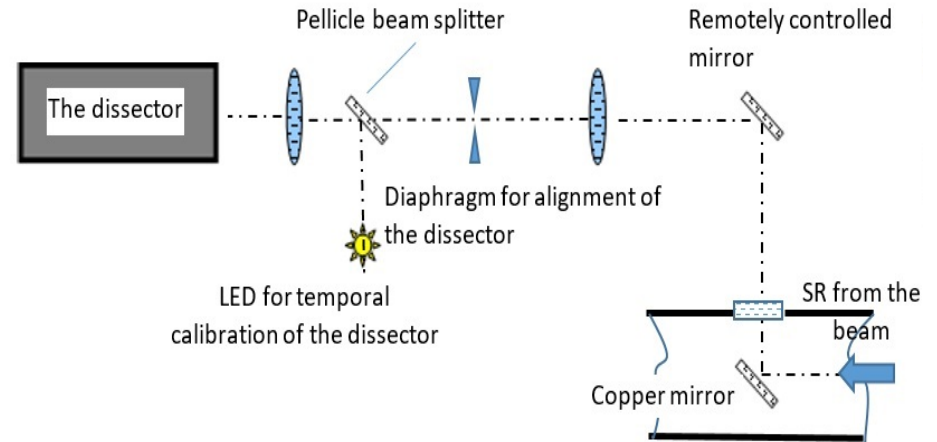

Layout of the diagnostics for acquisition of the longitudinal profile of the beam



# Optical diagnostic of electron beam parameters

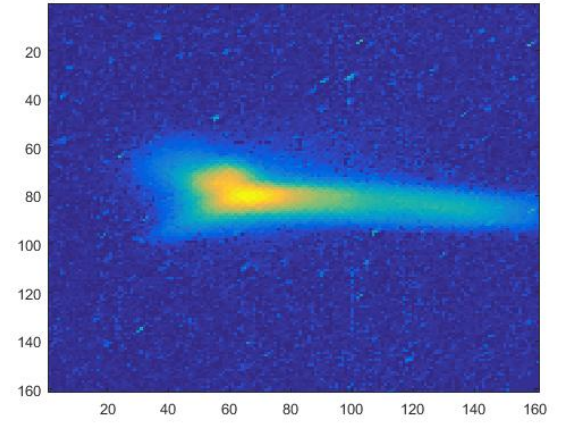
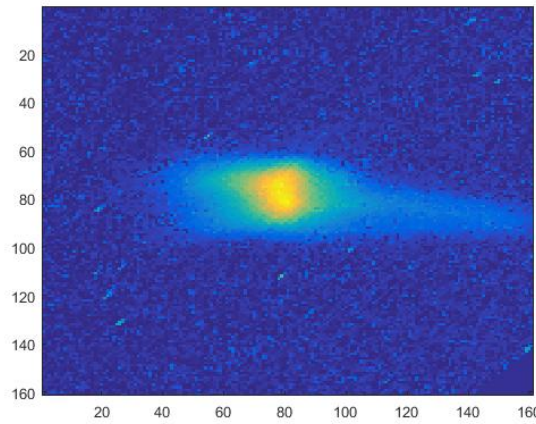
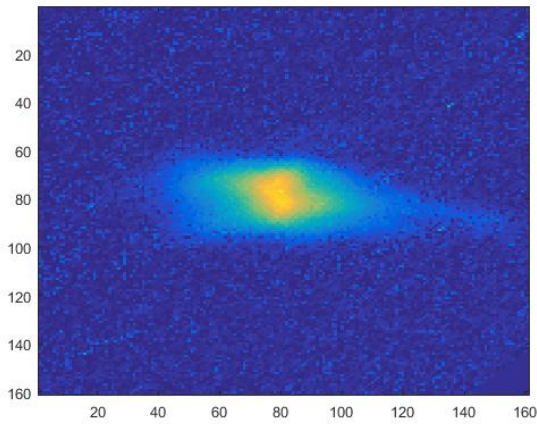

## Examples of acquired transverse beam profiles

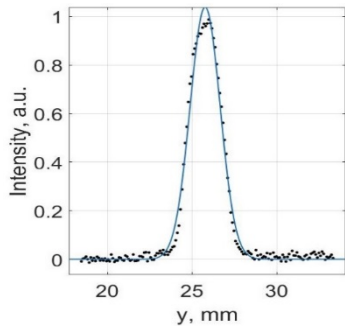

Vertical beam profile

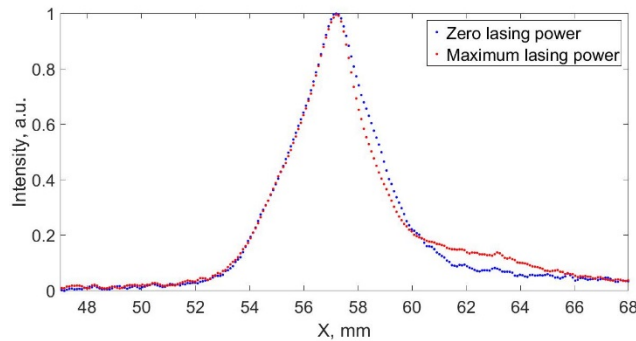

Horizontal profiles acquired during the 2<sup>nd</sup> run

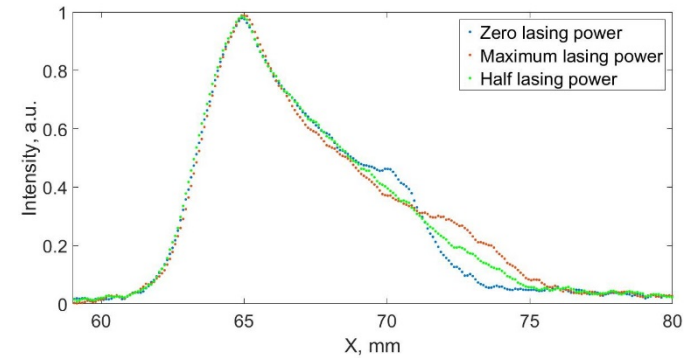

Horizontal profiles acquired during the 1<sup>st</sup> run

## 5. Perspective of ERL with SC cavities at Budker INP

### 5.1 MARS –Multiturn Accelerator Recuperator Source

- At SRI-97 conference for realization of a fully spatially coherent X-ray source was proposed by Kulipanov G., Skrinsky A., Vinokurov N. using of accelerators-recirculators with energy recuperation (SRI-97)

See: [1] *MARS - recirculator-based diffraction limited X-ray source. // Budker INP preprint No 97-103 (1997);*

[2] *Kulipanov G., Skrinsky A., Vinokurov N. Synchrotron light sources and recent development of accelerator technology. // J. of Synchrotron Radiation –1998 V.5 pt.3 P.176).*

- After SRI-2000, the idea of using the accelerators-recuperators for creation of 4<sup>th</sup> generation of SR sources has been actively discussed at Jefferson Lab, Cornell Uni., KEK, BNL, LBL, Erlangen Uni., Daresbury Lab.

# Layout of 5.7 GeV four-pass accelerator-recuperator

At "SRI-2000" (Berlin, Germany)

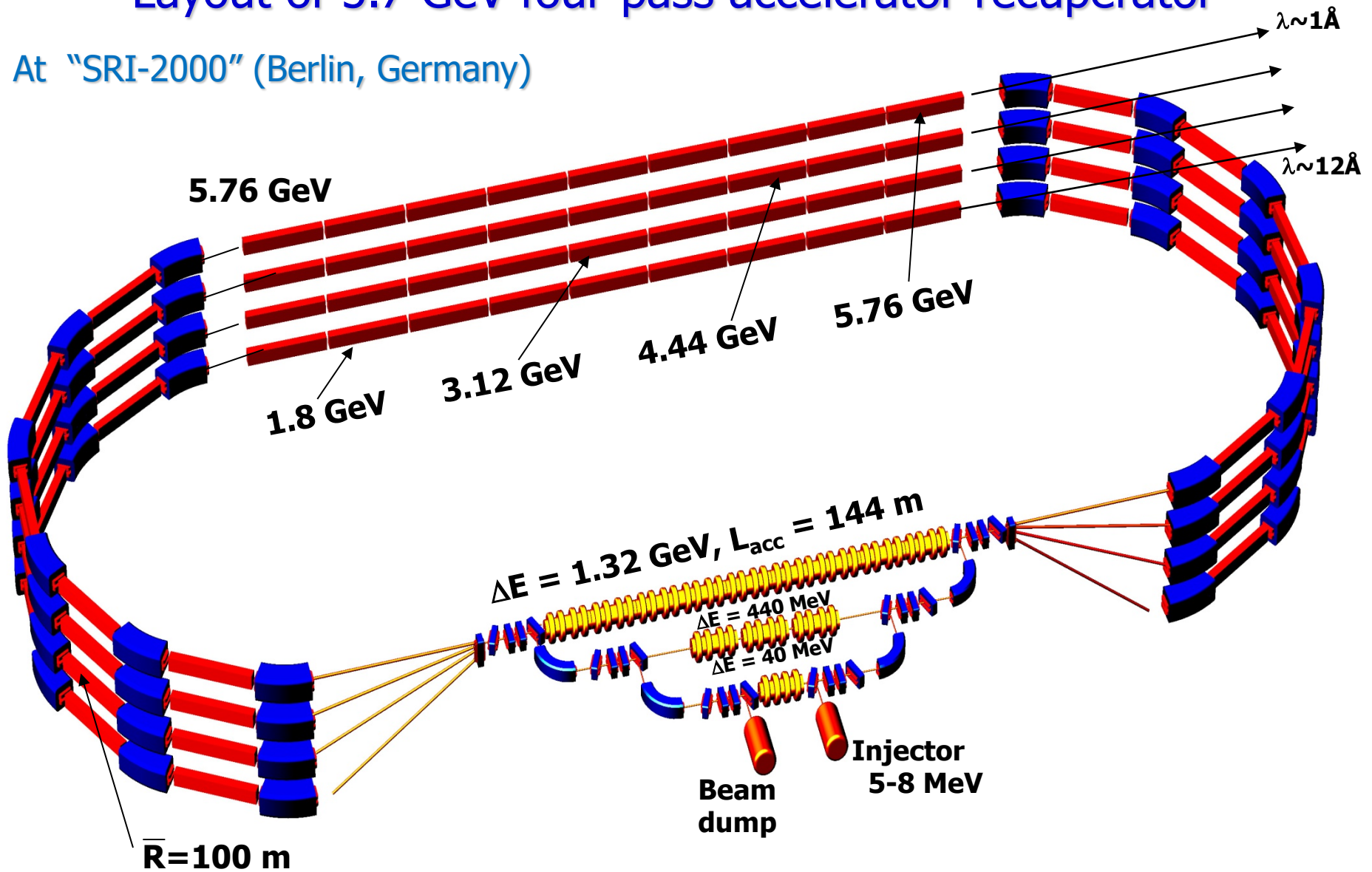

# Cascade injection – effective solution of important problems of ERL

- ❑ Decrease in radiation hazard and limitation of induced radioactivity due to low energy of electrons at dump (5-8 MeV).
- ❑ Reduction in the cost of construction and RF power system for the injector
- ❑ Simplification the problem of focusing particles of different energies travelling simultaneously in the accelerating structure, because the cascade scheme enables injection of electrons into all accelerating structures with energies of no less than  $E_{max}/10$  ( $E_{max}$  is the maximum energy of electrons traveling in the accelerating structure).

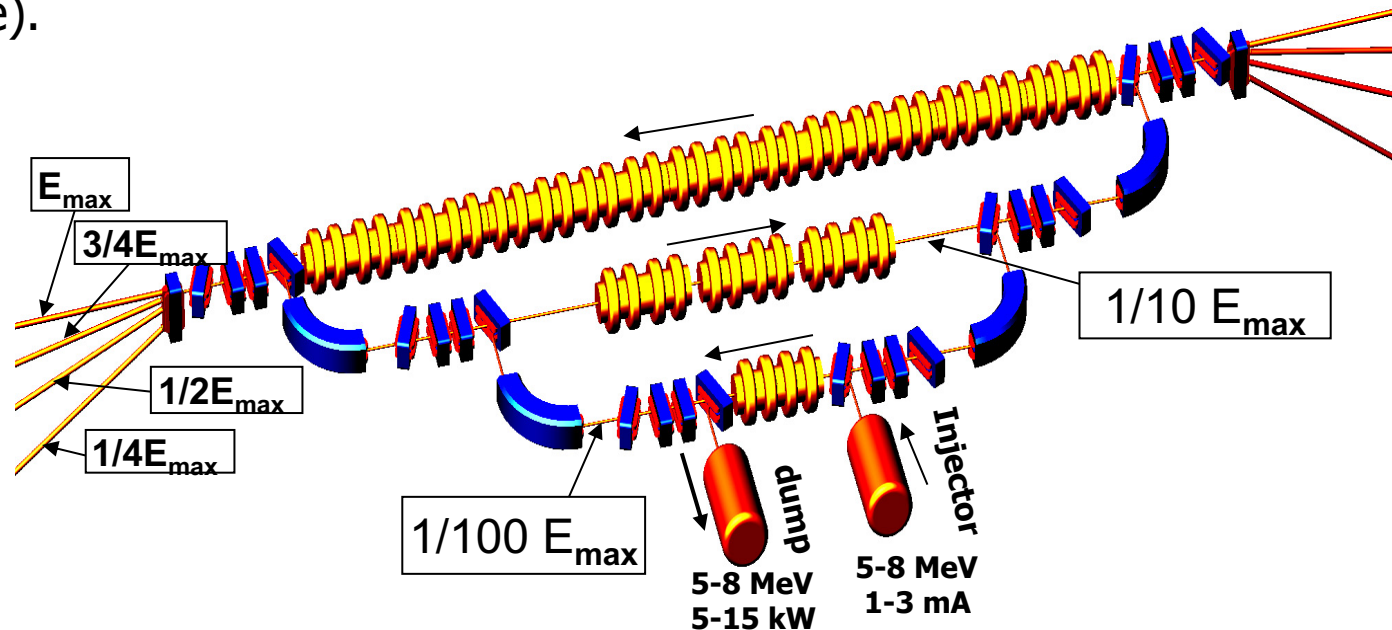

**First linac has 5-8 MeV energy and does not use energy recovery.  
For booster linacs (30 MeV and 330 MeV energy gain) energy recovery is used.**

## 5.2. ERL with separated tracks for accelerated and decelerated beams

It was suggested at ERL-2011 (G. Kulipanov, Ya. Getmanov, O. Shevchenko, A. Skrinsky, A. Tribendis, N. Vinokurov, V. Volkov, “Multiturn ERL X-ray Source(MARS) Feasibility study,” ERL-2011, October 2011, KEK) to turn to an accelerator-recuperator scheme with two acceleration sections, similar to the scheme of the US accelerator CEBAF. Such schemes are considered below.

# The simplest scheme of ERL (for understanding) with separated tracks

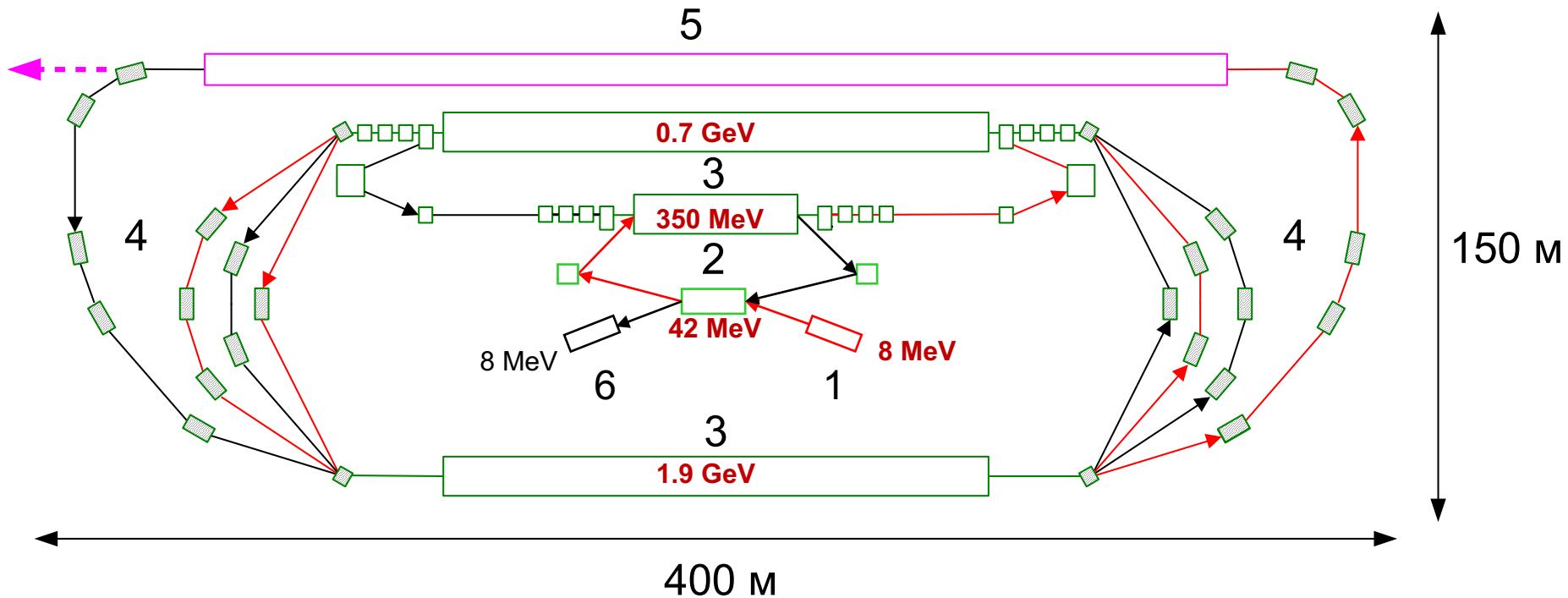

1 – injector, 2 – preliminary accelerating system, 3 – main accelerating RF structure, 4 – magnets, 5 – undulator, 6 – dump.

red arrows – accelerating bunch

black arrows – used decelerating bunch



# Full Spatial Coherent multiturn ERL X-Ray Source MARS

MULTIPASS ACCELERATOR-RECUPERATORS SOURCE

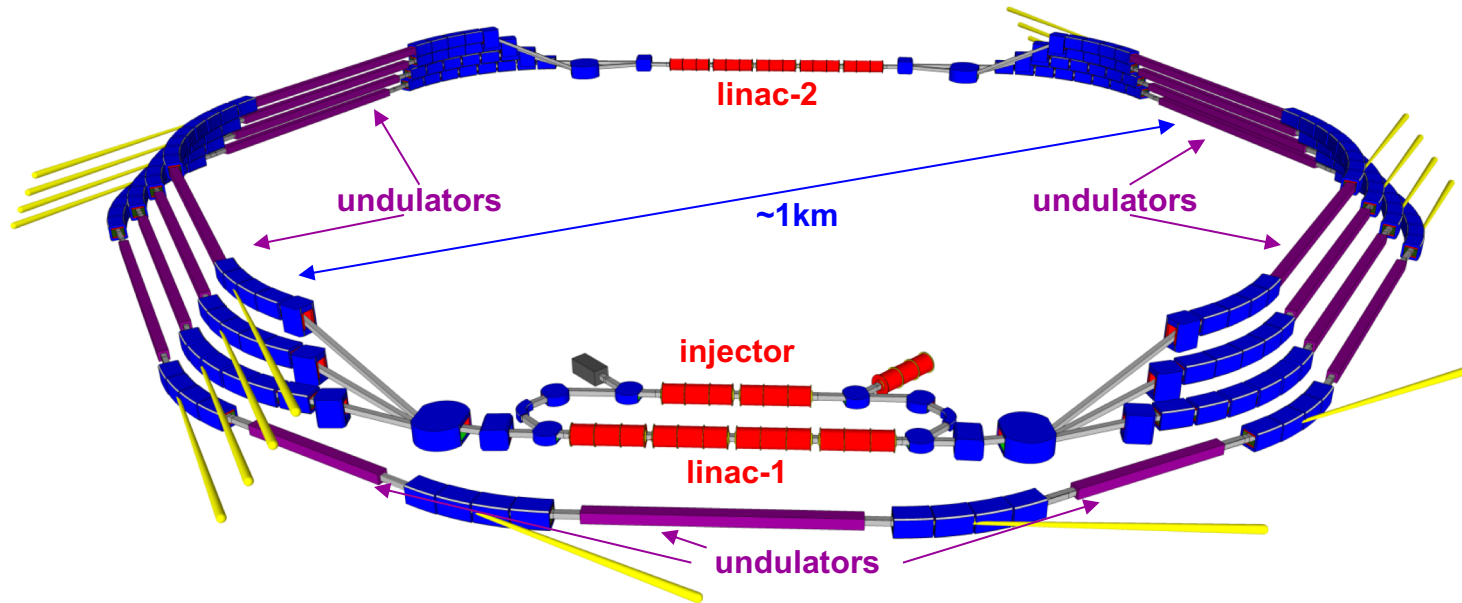

◆ Energy range	5.6, 3.8, 3, 1.2 GeV	◆ Bunch length	0.1 – 1 ps
◆ Average current	10 mA	◆ 7 undulators for	5.6 GeV
◆ Peak current	10 A	◆ 4 undulators for	3.8 GeV
◆ Normalized Emittance	$10^{-7}$ m·rad	◆ 4 undulators for	3 GeV
◆ Bunch charge	$10^{-11}$ C	◆ 4 undulators for	1.2 GeV

# Project of FEL for EUV Lithography

(compact 13.5-nm free-electron laser for extreme ultraviolet lithography, Y. Socol, G.N. Kulipanov, A.N. Matveenko, O.A. Shevchenko, and N.A. Vinokurov, Phys. Rev. ST AB, Vol. 14, No 4. – 040702-1 – 040702-7, 2011).

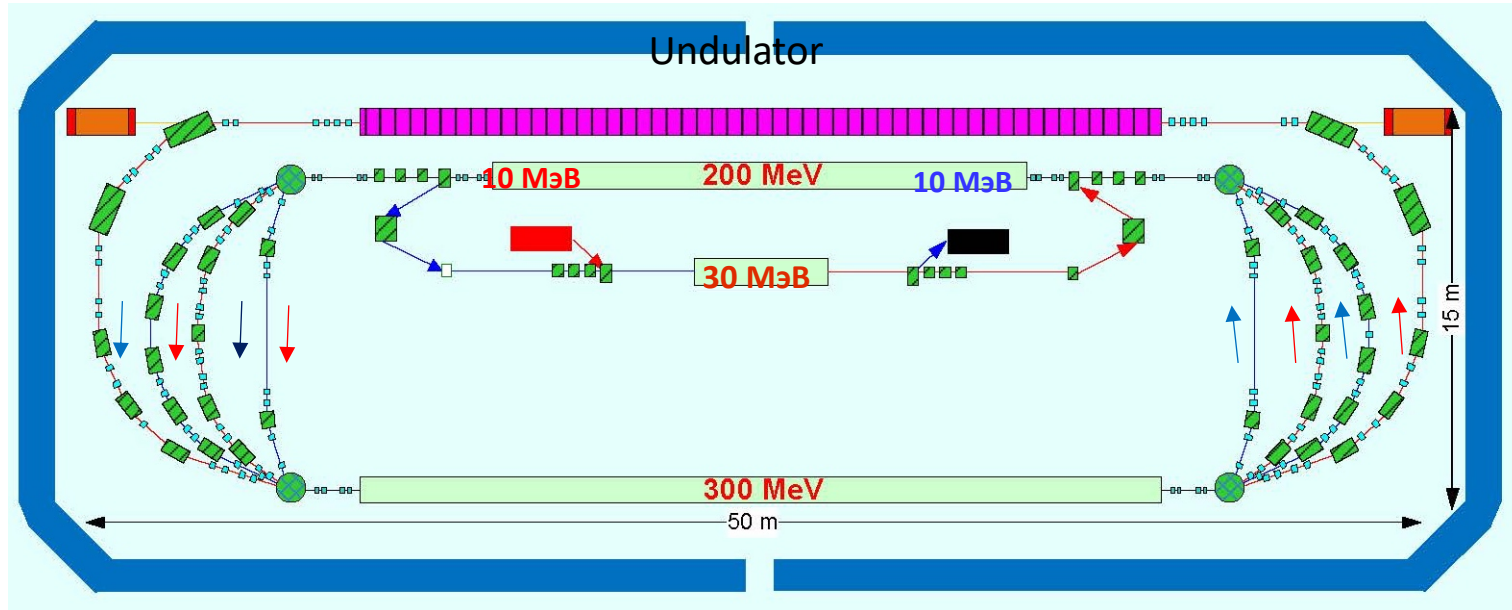

$\lambda$	13.5 nm
$E_e$	1 GeV
$P_{av}$	10 kW
$I$	10-20 mA
$\lambda_u$	3 cm

→ accelerated beam  
→ decelerated beam



*Thank you for your attention!*