

PIN DIODE IN A MEDICAL ACCELERATOR – A PROOF OF PRINCIPLE AND PRELIMINARY MEASUREMENTS

A. Pozenel¹, M. Eichinger, S. Enke, M. Furfinger, C. Kurfurst, M. Repovz
EBG MedAustron, 2700 Wr. Neustadt, Austria

Abstract

The MedAustron Ion Therapy Center located south of Vienna, Austria, is a cancer treatment facility utilizing a particle therapy accelerator optimized for protons and carbon ions. The beam is injected into the synchrotron, accelerated to the desired speed and extracted to be guided into one of four irradiation rooms. During extraction a certain amount of particles is lost which is measured with a PIN diode. In this paper the measurement method of this system is presented, as well as some measurement attempts documented.

INTRODUCTION

MedAustron is a therapy center capable of both offering cancer treatment with proton and carbon beams up to 250 MeV and 400 MeV/n, respectively. In addition to that higher energy beams up to 800 MeV will be available soon for non-clinical research purposes.

The particle beam is circulated in a synchrotron until it has reached a given energy and is then extracted to reach one of three irradiation rooms. Naturally one wants to extract in an efficient way and avoid particle losses on physical components of the accelerator. As such, thorough commissioning of the extraction process and components is needed, which heavily relies on beam diagnostic devices. One of these devices at MedAustron is the PIN system described in this paper [1].

A description of the measurement principle will be given, followed by the theoretical implementation at MedAustron and concluded by the development process, challenges and lessons learned. Finally, an outlook on further plans at MedAustron regarding the PIN system and extraction efficiency investigation will be given.

PRINCIPLE OF OPERATION

A PIN diode is a diode with a wide intrinsic region, compared to a standard diode which has a much narrower P and N junction. The idea is to operate the diode in reverse bias mode so it does not conduct in normal conditions, except for a small dark current. When a charged particle impacts on the intrinsic region it creates electron-hole pairs. The carriers are immediately swept out of the region by the reverse bias field which creates a measurable current. The depletion region extends almost over the complete intrinsic region of the diode, and naturally the bigger the intrinsic region is, the more area there is where impacting particles can be detected.

By adjusting the reverse bias voltage across the diode anode and cathode the size of the depletion region can be influenced. Naturally, a higher voltage results in a wider region. However, a higher voltage also results in a higher dark current, which can be a problem for small signals.

IMPLEMENTATION AT MEDAUSTRON

In MedAustron's case (see Figure 1) the diode is made from hydrogenated² amorphous silicon (a-Si:H) with chromium-gold metallization on both surfaces. The active detector area is 15 mm by 40 mm and has a thickness of 0.3-0.5 mm.

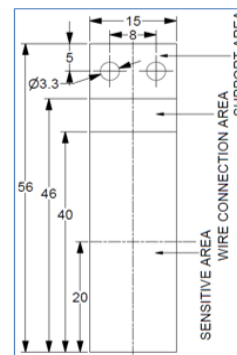

Figure 1: Mechanical structure of PIN.

The PIN diode used at MedAustron is suited for voltages from -10 V to +1 V. However, these reverse bias levels only apply for vacuum and should be applied gradually (e.g. over 30 s). Depending on the voltage level it can take up to one hour until a stable dark current is reached [2].

Connections to the electrodes are established using two clamps made from copper beryllium that can be adjusted with screws, with cables leading to two SMA connectors.

The PIN is mounted on a flange that is fixed to the beam-line and located in the extraction magnetic septum in a way that the active detector area covers most of the wall area (see Figure 2). This way, close to all particles that are lost on this surface during extraction should be detected.

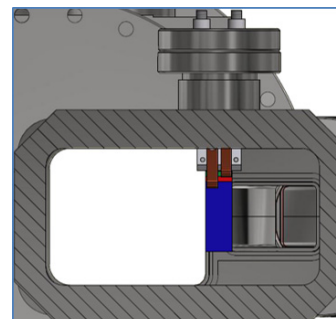

Figure 2: PIN as seen by beam.

¹ alexander.pozenel@medaustron.at

² Hydrogenation is necessary to improve photoconductivity in amorphous silicon

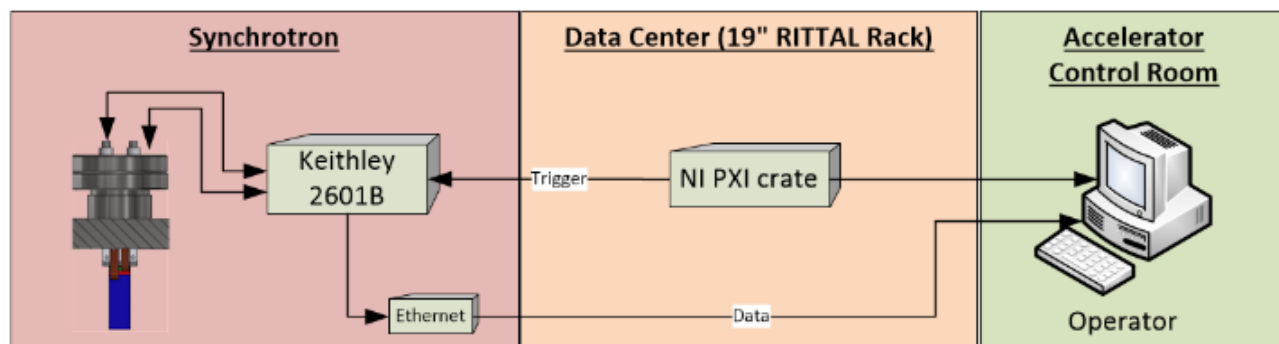

Figure 3: PIN system block diagram.

For supplying power to the diode and reading signals back a Keithley 2601B sourcemeter unit (SMU) is used. Two CB50 cables with SMU connectors, about 15 meters in length each, are used to establish a connection between the diode and the SMU. A connection to the control system is established using the Ethernet port of the SMU and the TSP-Link which is extensively explained in the manufacturer documentation [2].

Triggers for starting a measurement are provided to the device from a National Instruments PXI crate [3] via optical signals that are converted to TTL logic using a simple circuit that was developed in-house, connected to the Digital IO DSUB25.

For a complete system block diagram please refer to Figure 3. It is split into the three regions where PIN hardware or software is located.

MEASUREMENTS SO FAR

As mentioned before, it was known from previous research and basic electrical principles that the diode has some kind of charge-up time until the depletion region is fully formed and the dark current does not change significantly any more.

The first measurements with a PIN at MedAustron were performed using the aforementioned sourcemeter connected directly to a laptop running the software KickStart available from the manufacturer. A remote desktop connection to the laptop was established from the Accelerator Control Room (ACR) and the accelerator settings were changed so a lot of beam would impact on the PIN. As can be seen in Figure 4 the current generated by the beam particles hitting the PIN is visibly measurable.

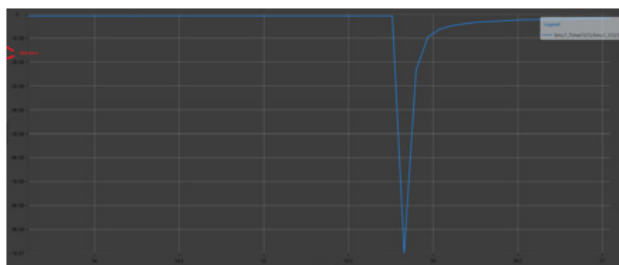

Figure 4: First PIN measurement.

With this proof of principle a complete system design was done to fit to the MedAustron Beam Diagnostic architecture. As the next step was developing a setup that would allow us to control and read out the sourcemeter remotely via MedAustron's Accelerator Control System (ACS) [4] a communication protocol needed to be chosen. It was decided to use an Ethernet connection to the sourcemeter and control it via TSP-Link.

The Controls team developed a GUI that was integrated into the accelerator control system that allows the user to change parameters like the voltage applied to the diode, the measurement time and a deadtime before values are added to the measurement. It also shows a plot of the acquired values over time, collected charge and the time elapsed since the device was turned on. This last parameter is of great importance as the manufacturer of the sourcemeter recommends a waiting time of 60 minutes before performing any measurements to guarantee a certain accuracy.

The first voltage applied was -1 V, which did beautifully show the charge-up time of the diode (see Figure 5). The oscillations can most likely be traced back to measurement noise. As one always has to send a cycle to the PIN to start a measurement of, in this case, 30 seconds interruptions between the individual measurements can be seen in the plot. From the graph one can estimate that it takes about six minutes until the dark current is somewhat stable³, i.e. does not have a significant slope any more.

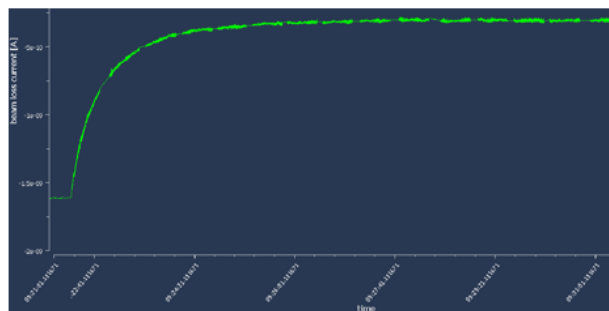

Figure 5: PIN charge-up at -1V.

The next voltage applied was +1 V, mainly to see what would happen. As expected, the results were not very good (see Figure 6) and the diode did not settle on a stable dark current. This proves that the measurement calls for the diode being used in reverse biased mode.

³ Eleven 30-second increments plus some time in between to start the measurements

Content from this work may be used under the terms of the CC BY 3.0 licence (© 2018). Any distribution of this work must maintain attribution to the author(s), title of the work, publisher, and DOI.

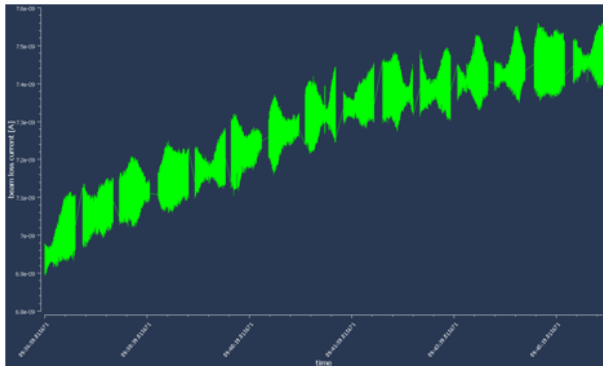

Figure 6: PIN charge-up at +1V.

Naturally, it was decided to go back to reverse bias mode with an increased voltage of -3 V. Again, the charge-up can nicely be seen in Figure 7 plus it is worth noting that it happened much faster at this voltage.

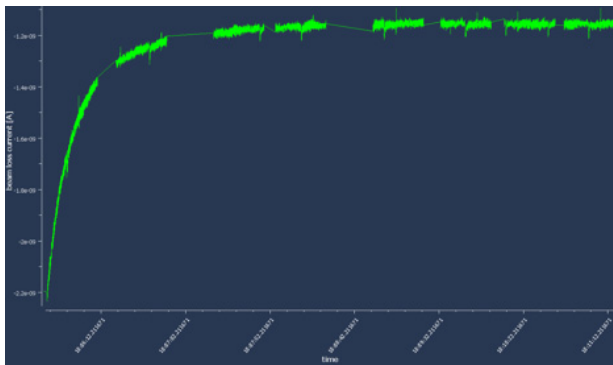

Figure 7: PIN charge-up at -3V.

It is not yet clear what the spikes visible in the plot are, as their pattern cannot be related to anything specific at the moment. More measurements are needed to investigate these occurrences, unfortunately this will not be possible in time to be included in this paper.

SUMMARY AND CONCLUSIONS

The measurements taken seem to prove that the PIN works in principle, however there is still a great need for further investigation and fine-tuning. Further extensive studies of the PIN system's behaviour, finding of optimum parameters or acquisition of sufficient data for the investigation of impacts that machine settings have on the measurement are important topics for the future.

Further measurements are planned and will hopefully allow the relation of beam behaviour and PIN measurement. The measurements taken certainly look promising.

For the future it is planned to compare the measurement results of the PIN system to the profile intensity monitor at the immediate start of the Extraction line, the QIM.

It is furthermore planned to use the PIN to compare the efficiency of two extraction principles: RF-Knockout and Betatron extraction, the latter being the currently used one at MedAustron.

REFERENCES

- [1] F. Osmic, M. Feurstein, A. Gyorgy, A. Kerschbaum, M. Repovz, S. Schwarz, "Overview of the Beam Diagnostic in the MedAustron Accelerator: Design Choices and Test Beam Commissioning"
<http://accelconf.web.cern.ch/accelconf/ipac2012/papers/moppr002.pdf>
- [2] Tektronix Keithley Current SourceMeter SMU Manuals
<https://www.tek.com/keithley-source-measure-units/smu-2600b-series-sourcemeter>
- [3] M. Caldara, H. Caracciolo, Univ. Milano Bicocca, Italy, "Diamond Detector Specifications in CNAO machine"
- [4] J. Dedič, Z. Kroflič, R. Štefanič, R. Tavčar, J. Gutleber, „Timing System for MedAustron Based on Off-The-Shelf MRF Transport Layer”, Proceedings of IPAC2011, held from 4 - 9 September 2011 in San Sebastián, Spain, <https://accelconf.web.cern.ch/accelconf/IPAC2011/papers/mopc147.pdf>
- [5] J. Gutleber, A. Brett, R. Moser, M. Marchhart, C. Torcato de Matos, J. Dedič. „The MedAustron Accelerator Control System”, Proceedings of ICALEPCS2011, held from 10-14th October 2011 in Grenoble, France, [http://accelconf.web.cern.ch/AccelConf/icaleps2011/papers/mobaust03.pdf](http://accelconf.web.cern.ch/AccelConf/icalleps2011/papers/mobaust03.pdf)