

Content from this work may be used under the terms of the CC BY 3.0 licence (© 2015). Any distribution of this work must maintain attribution to the author(s), title of the work, publisher, and DOI.

LATTICE AND BEAM DYNAMICS OF THE ENERGY RECOVERY MODE OF THE MAINZ ENERGY-RECOVERING SUPERCONDUCTING ACCELERATOR MESA*

D. Simon[†], K. Aulenbacher, R. Heine, F. Schlander
 Institut für Kernphysik, Johannes Gutenberg-Universität Mainz,
 D-55128 Mainz, Germany

Abstract

The Mainz Energy-recovering Superconducting Accelerator (MESA) is a proposed multi-turn energy recovery linac for particle physics experiments [1, 2]. It will be built at the Institute for Nuclear Physics (KPH) at Mainz University. Because of the multi-turn energy recovery mode, there are particular demands on the beam dynamics. We present the current status of the lattice development.

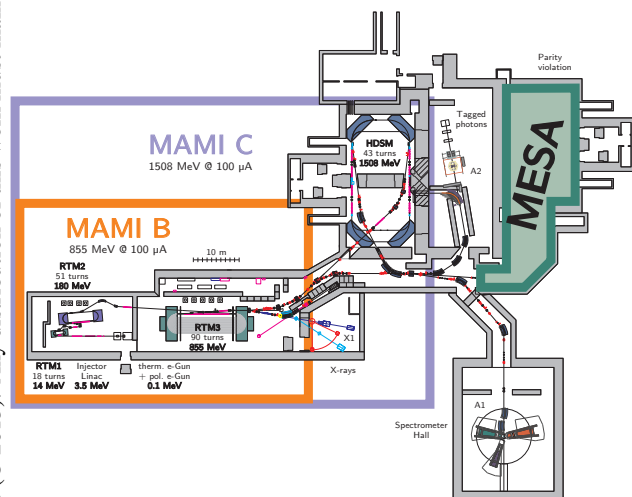

Figure 1: Floor plan of the MAMI facility. Space intended for MESA is marked in green.

INTRODUCTION

The MESA accelerator will be a CW-electron beam accelerator and will operate in two modes: an energy recovery mode (ER) with currents up to 1 mA (up to 10 mA in stage-2) and a polarized external beam mode (EB) with up to 150 μA. As presented in [3], MESA will be a double-sided recirculating linac with vertical stacking of the return arcs similar to a proposal for the LHeC ERL test facility [4]. A normal conducting linac with an extraction energy of 5 MeV will be used as injector. The linear lattice was designed with our own matrix optics program "Beam Optics" and also with

* Work supported by the German Federal Ministry of Education and Research (BMBF) and German Research Foundation (DFG) under the Cluster of Excellence "PRISMA"

[†] simon@kph.uni-mainz.de

Mad X [5]. To allow for space charge effects and pseudo-damping of the TESLA 9-cell cavities [6], the lattice was additionally simulated with PARMELA [7].

As shown in Fig. 3, MESA consists of:

- a 100 keV polarized photo-cathode electron gun [8],
- a normal conducting injector linac with an extraction energy of 5 MeV [2, 9],
- two superconducting linac modules with an energy gain of 25 MeV each [10],
- four spreader sections for separating and recombining the beam [3] vertically,
- five 180° arcs for beam recirculation,
- two chicanes for the injection and extraction of the 5 MeV beam,
- an 180° bypass arc for ER mode incorporating the internal experiment and a chicane to adjust the path-length (not shown in Fig. 3),
- a beam line to the external experiment.

SPACE CONSTRAINTS

MESA will be built in three existing halls formerly used for Experiments at the Mainz Microtron (MAMI) [11] (as shown in Fig. 1). These halls are located 10 m underground. Therefore alteration of the building is a challenge, due to the building statics. The main accelerator will be located in two of these halls; the third is appointed for the experiments. Due to the space restrictions, the lattice for MESA was optimized for a footprint area of circa 7.7 m × 27 m [3].

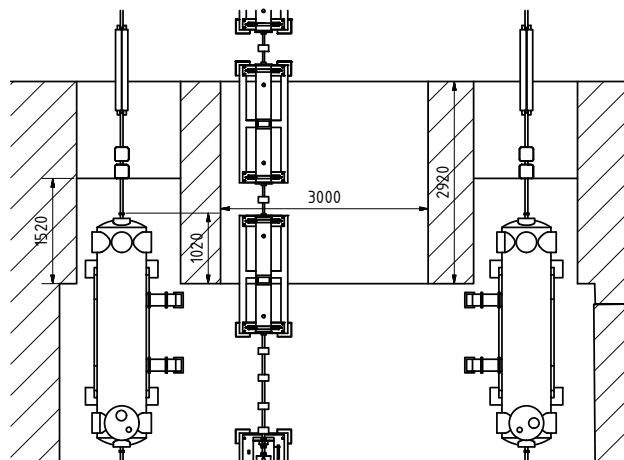

Figure 2: Sketch of the top view of the walls including the cryomodules and the injector linac (old concept).

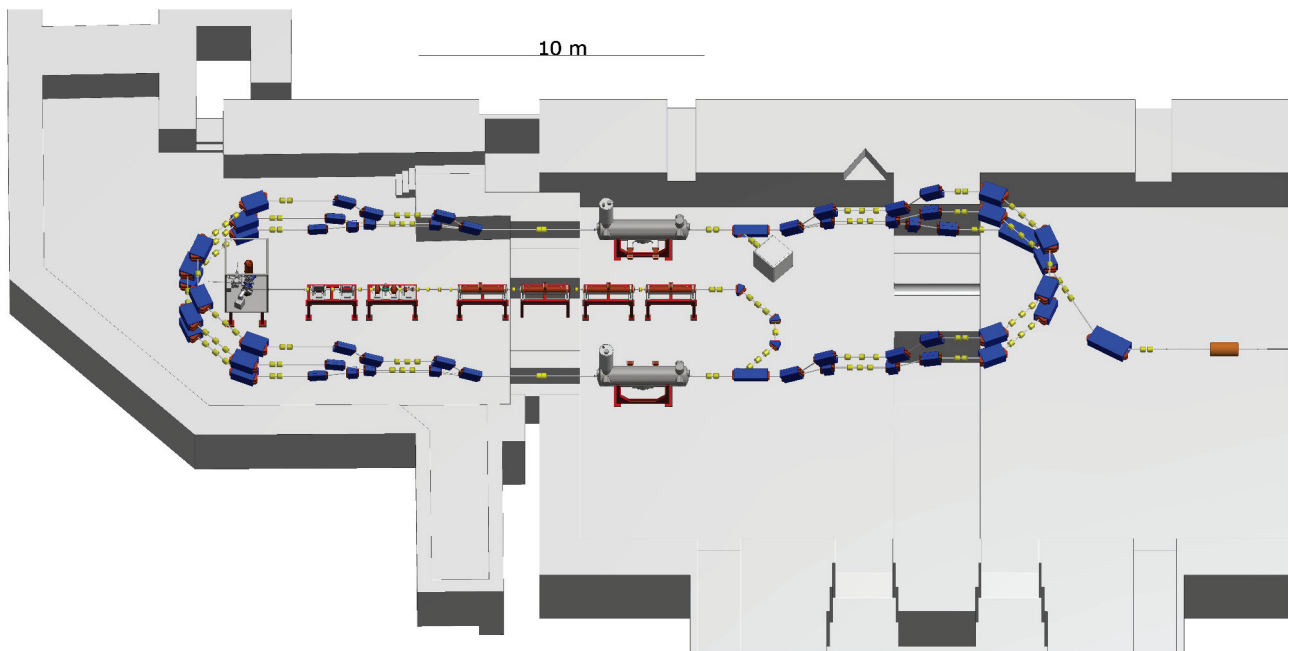

Figure 3: A 3D sketch of MESA, without the beamline for the internal experiment (new concept).

Further investigations have shown that, due to the statics of the building, the desired wide penetration of the wall for the accelerator is out of budget. Therefore, a structurally more stable aperture for the accelerator with three separated openings leaving two pillars as support for the building as shown in Fig. 2 was considered. In this concept, the cryomodules would be partly located in the aperture of the wall. This would limit the access to the cryomodules and maintenance of the cryomodules would nearly be impossible.

Because of the limited access to the cryomodules, this concept was dismissed. As possible solution, the position of the cryomodules could be relocated outside the wall, as shown in Fig. 3. This would increase the large semi-axis of the accelerator to 31 m, it would expand the accelerator into the third hall and would reduce the space for the experiments. To counteract this, an extension of the experimental hall has been requested, but has not yet been approved.

The changes of the lattice for this concept have been checked with "Beam Optics", but have not been fully modeled in the PARMELA simulations yet.

PARMELA SIMULATION ER MODE

The PARMELA simulation is based on the lattice shown in [3]. It is not based on the lattice shown in Fig. 3, since this is a rather recent development. For the simulation, the dimensions of the cryomodules were taken from the ELBE modules [12, 13]. The accelerating field data was obtained from Superfish for a TESLA 9-cell cavity; each cell was modeled individually. The two end-group cells also include the beam pipes to allow for fringe field effects [3].

In ER mode, there are four passes through the cryomodules, of which two are accelerating. This results in an energy of 105 MeV for the internal experiment. To reduce the energy

spread of the beam, MESA is designed as a non-isochronous recirculator, as proposed in [14]. But if isochronous recirculation is needed, it should be possible as well. Thus, highly flexible arcs are mandatory to adjust R_{56} and to compensate the momentum compaction of the beam spreaders.

Due to the asymmetrical beta functions, energy recovery is not possible with the beam optics of the EB mode as proposed in [3]. Therefore, a symmetrical adjustment of the beam optics around the mirror plane of the main linac cryomodules and the arcs is necessary. One also has to take into account the M_{12} -matrix element or M_{34} -matrix element respectively, of each turn for beam break-up [15, 16].

$$M_{12}(i \rightarrow f) = \gamma_i \sqrt{\frac{\beta_i \beta_f}{\gamma_i \gamma_f}} \sin \Psi \quad (1)$$

M_{12} : matrix element; β : initial (final) Twiss parameter;
 γ : Lorentz factor; Ψ : Betatron phase advance

This is the reason why the beta functions in the cryomodules have to be as small as possible. A too restricted confinement by the betatron phase advance could lead to restraints of the momentum compaction factor. It follows that the allowable beta functions enclosing the main linacs are of the order of magnitude of the modules' length and have to be the same for all arcs.

Furthermore, one has to take the large difference of space charge forces into account due to very different beam currents at the two modes of operation. This also strongly influences the lattice focussing. Moreover, the beta functions at the end of the injector vary for the different beam currents, as does the focussing of the cryomodule for the first passing. The injection arc has to be capable of matching these beta functions on the main accelerator.

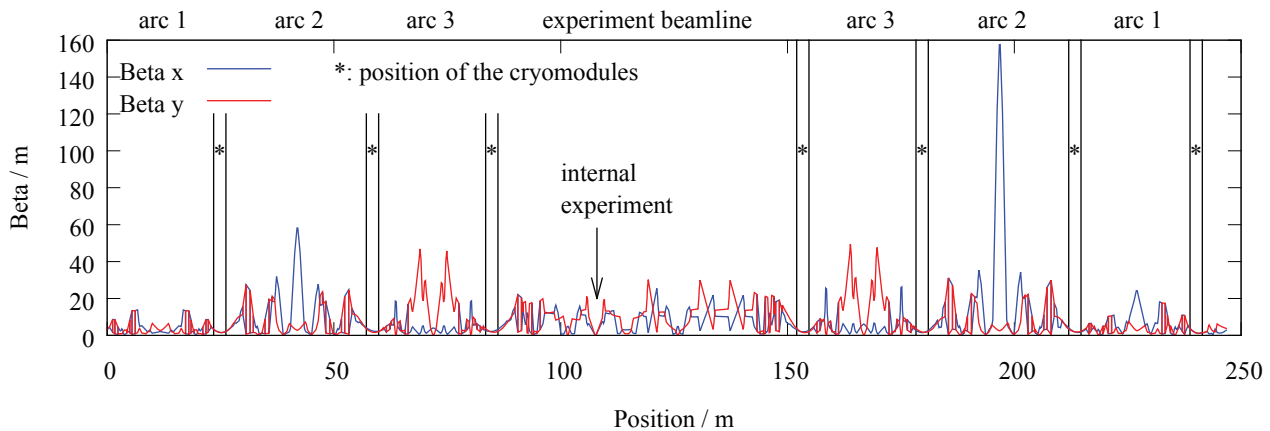

Figure 4: Beam beta functions of MESA in ER mode from 30 MeV up to 105 MeV and back down to 5 MeV, including space charge calculated with PARMELA.

Fig. 4 shows the beta function of the main accelerator including the experiment beam line and the deceleration of the beam for a beam current of $I = 150 \mu\text{A}$. As a start-to-end simulation for the ER mode has not been finished yet, the simulation starts at 30 MeV. For this simulation, the momentum compaction of all arcs was set at $R_{56} = -0.3 \text{ mm}/\%c_0$ and the synchronous phase was set at $\psi_s = 3^\circ$. For the deceleration, the phase was set to $\psi_s = 177^\circ$ in order to use phase focussing. Therefore, a chicane in the beam line of the internal experiment is mandatory to adjust the path length by $(1 - \frac{2\psi_s}{\pi})\lambda_{RF}$. This is to achieve the synchronous phase of the deceleration passes for different accelerating synchronous phases.

Further optimization of the optics is needed, because the envelope of the beam rises after deceleration up to 3.5 mm in the arcs. This could lead to beam losses in the arcs through the halo of the beam. The rise of the beam size is mainly caused by a rise of energy spread due to the deceleration. A scan of R_{56} vs. a synchronous phase ψ_s of the main linac should help to find a better setting of the optics and minimize the beam size.

SUMMARY & OUTLOOK

We have presented the current status of the lattice development and discussed the challenges we are confronted with in the design process.

The next step is to redesign the beam line for the internal experiment due to the increased footprint enforced by the building constraints, and implement the changes for a start-to-end simulation in PARMELA. Furthermore, a scan of R_{56} vs. a synchronous phase ψ_s of the main linac, as done for the EB mode in [3], has to be done for the ER mode in order to find the optimum settings for different beam currents.

REFERENCES

[1] R. Heine, et al. "MESA-Sketch of an Energy Recovery LINAC for Nuclear Physics Experiments at Mainz", IPAC 2012, New Orleans, USA, TUPPR073, (2012).

[2] R. Heine, K. Aulenbacher, "Injector LINAC for the MESA Facility", IPAC 2013, Shanghai, China, WEPWA011, (2013).
 [3] R. Heine, et al., "Lattice and start to end simulation of the Mainz Energy-recovering Superconducting Accelerator MESA", IPAC 2014, Dresden, Germany, MOPRO108, (2014).
 [4] A. Valloni, et al., "Strawman Optics Design For the LHeC ERL Test Facility", IPAC2013, Shanghai, China, TUPME055, (2013).
 [5] W. Herr, F. Schmidt, "A MAD-X Primer", Geneva, Switzerland, CERN-AB-2004-027-ABP, (2004).
 [6] B. Aune, et al., "Superconducting TESLA cavities", Phys Rev ST-AB **3** 092001, (2000)
 [7] L.M. Young, "PARMELA", Los Alamos, USA, LA-UR-96-1835, (2005).
 [8] S. Friederich, et al. "A new photoemissive electron source for MESA", IPAC 2015, Richmond, USA, TUPWA044, (2015).
 [9] R. Heine, et al. "Further investigation on the MESA injector", IPAC 2015, Richmond, USA, TUPWA045, (2015).
 [10] F. Schlander, et al., "1.3 GHz SRF cryomodules for the Mainz Energy-recovering Superconducting Accelerator MESA", IPAC 2015, Richmond, USA, WEPMA041, (2015).
 [11] M. Dehn, et al., "The MAMI C accelerator", The European Physical Journal Special Topics **198.1** (2011).
 [12] P. McIntosh, et al. "SRF System Operation On the ALICE ERL Facility At Daresbury", SRF2009, Berlin, Germany, MOOBAU05, (2009).
 [13] J. Teichert, et al. "RF status of superconducting module development suitable for CW operation: ELBE cryostats", NIM A **557** 239-242, (2006).
 [14] H. Herminghaus, "On the inherent stability of non-isochronous recirculating accelerators", NIM A **314** 209-211, (1992).
 [15] S. Chen, et al. "Study on the multi-pass, multi-bunch beam breakup for 9-cell TESLA cavities in ERL", Chinese Physics C **37** 087001, (2013).
 [16] F. Schlander, et al. "Investigation of Cryomodules for the Mainz Energy-Recovering Superconducting Accelerator MESA", IPAC14, Dresden, Germany, WEPRI013, (2014).