

UPGRADE OF THE EXISTING PID CONTROLLER AND OXYGEN DETECTION ALARM SYSTEM FOR SRF MODULES OPERATING IN THE TAIWAN LIGHT SOURCE

F.-T. Chung[†], M.-S. Yeh, T.-C. Yu, Ch. Wang, M.-H. Chang, L.-H. Chang, L.-J. Chen, C.-H. Lo, Z.-K. Liu, M.-C. Lin, C.-L. Tsai, F.-Y. Chang
National Synchrotron Radiation Research Center, Hsinchu, Taiwan

Abstract

A Cornell-type superconducting RF cavity module was installed in the Taiwan Light Source (TLS) in 2004. New control electronics for the existing SRF modules have been designed, based on the original designs. In addition to the functions for operation, this SRF electronics system in the TLS also provides protection for the SRF modules and cryogenic system.

This paper presents the SRF electronics modifications, which will enhance machine protection and make it easy to adjust and optimize operational parameters.

INTRODUCTION

The initial analog electronics system for the SRF cavity module in TLS was designed by Connell University and made by ACCEL, a Germany manufacturer [1]. All PID controllers, which are used to regulate liquid helium levels and gas pressure in the helium vessel, were made by Omega Inc.

In the new SRF electronics, all OMEGA controllers will be replaced by an OMRON product. The reasons for the replacement will be explained below together with a new design of an improved protection mechanisms for the SRF cryogenics.

PID Controller Upgrade

In the TLS, the SRF electronics system uses OMEGA products for the main control and display components. To control the valves on the Cryogenic-Valve Box, a CN2001 controller (current loop control) with PID functions is used to regulate the liquid helium (LHe) levels, the helium vessel gas pressure and the Heat-Exchange (Hex) Gas temperature of the cavity's RF window as shown in Fig. 1.



Figure 1: Old PID controller CN2001 for cold gas/liquid control in the TLS.

All analog output signals will be recorded by an archiver system (ILC) at the NSRRC. Besides the analog output, the PID controllers also send internal operation parameters through RS232 (serial protocol) to another ILC system.

The old PID controllers cause now some problems. The first one is that communication faults, causing data loss, in the RS232 cannot be easily found intuitively. One way to fix the problem is to restart the ILC system.

The second trouble is that the CN2001 module, driving the output current or display panel, also gradually malfunctions after more than ten years. We replaced failed modules with spare modules, but that supply dwindles fast.

Although OMEGA Inc. announced a replacement version for the CN2001 (model: CN8261-FH1-AL1), the new wiring pin assignments is totally different and can't be adopted immediately in the TLS.

In addition, this new PID controller (CN8261-FH1-AL1) which was tested and used in the RF Lab (as shown in Fig. 2) for years, suffers from a high failure rate of its current output. Although the new model features rapid exchange capability and is hot-swappable by direct control from the front panel, its high failure rate becomes a reliability concern for daily operation of the TLS.

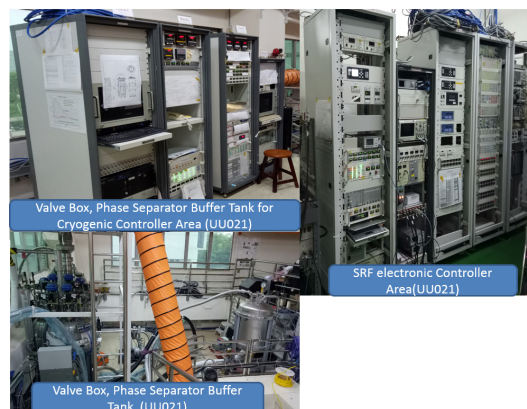

Figure 2: SRF electronics in the RF Lab at NSRRC.

Other PID temperature modules made by Omron Inc. (model: E5AC-CX2ASM-004) have been used for the TPS storage ring and the AC model has the same size as the current operational PID module (96x96 mm) in the TLS as shown in Fig. 3. The selected Omron PID controllers in the new TPS have been run now for over one year, and valve openings (current output percentage) can be seen through the display meter. The current-output is also robust. The disadvantage of the controller is that

[†] gofor@nsrrc.org.tw

only positive voltages are available, which however can be solved by adding an external potential offset.



Figure 3: Front panel for the new Omron PID controller.

To replace the old PID controllers by new modules, the RS232 communication is missing. To support this, a set of 12 channels current-to-voltage transducer, 14 display meters and 2 channels of heater power display by voltage divider and hall effect current measurement IC (ASC712 5A) are designed and assembled as shown in Fig. 4 and the results of heater power calibrations are shown in the Fig. 5.

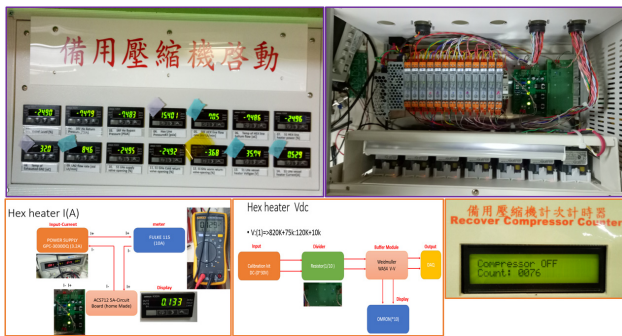

Figure 4: Integration of the Hex Power, Recovery Compressor display.

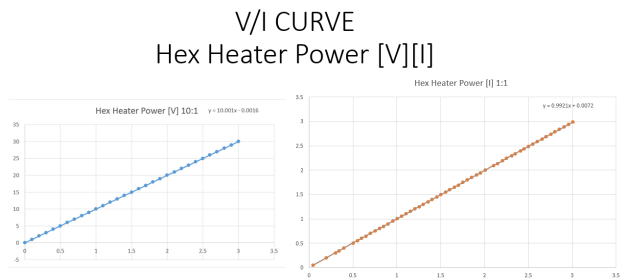

Figure 5: Voltage and current linearity for the hex power.

The display of the new module is using OMRON (k3gn-ndc) which is connected to current-to-voltage transducers (Weidmuller model: was4 pro) and the converted signals have a buffered output. After installation of the advertising panel for the recovery compressor status, the signals for the RS232 communication can be replaced gradually.

The final goal is to completely use a new version for the PID controller. That will ensure a continuous supply of spare parts and the complete replacement is scheduled for August of this year.

TLS Voice Broadcast System Integration

The old oxygen detection system activates a flash light and alarm horn when triggered. However, nearby in the TLS tunnel there are many noisy pumps and motors and the oxygen, O₂, deficiency detector signals may not be able to attract the attention of personnel nearby due to the high sound level.

To improve this, a set of voice systems (MP3 Wave), warning slogans and flashing lights, are installed as a reminder to nearby personnel. An MP3 player module TDR025 is commonly used. Eight status signals in this package can be selected by commands from the SD card. Except for an external SERIAL communications protocol to control the module, there are also fixed modes to be selected through an internal identification code in the SD card like recycle, assign or manual coding with up to 256 sets. The MP3 module is thus easy and convenient to update for new voice signals. These features are different from the first version which requires a download of voice files to the ROM (Read Only Memory) and the use of a microphone while downloading.

Because the sound must be heard in each corner, a 100 W power amplifier, model LIN-A960, is used with matching speakers YCN-R200 (impedance: 4 OHM) installed at six points along the tunnel walls. Warning lights are inserted into the door, to remind people of hypoxia as shown in Fig. 6.



Figure 6: Oxygen, O₂, deficiency detector module.

Although MP3 modules have been used and tested to broadcast alarms in the TPS [2] and RF Lab, we are not yet fully satisfied with the quality of the modules. Hence, the Mp3 modules need to be augmented with external improvements due to missing watch-dog functions. Using a PLC (Fatek) controller with a programmable state-machine (as shown in Fig. 7) and continuous test, the function is ready to be connected to the whole system.

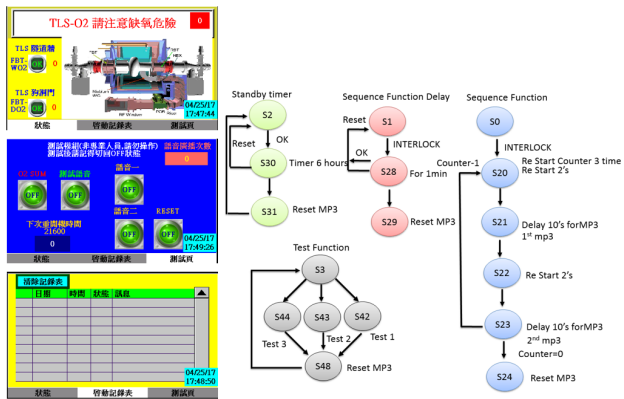

Figure 7: State machine for the MP3 alarm system.

Commonly used status displays are lights and switching modules. In this improved version, a man-machine interface (MMI) is used which can be mounted on a 3U rack, and the MMI has RS232 and USB connections to other devices. New rack mount kits are developed in house for quick installation or disassembly on the 3U Panel. The MMI control pages are divided into three parts: The first is the main page to display status or values. The second one is to record the status with event time and recovery status. The third one is provided for test and the operator can work through this page to test the design functions prior to on-site installation.

Update the Function of the Cryo Area Trip

The original trigger signal for the TLS Cryo Area Trip comes from a fast pressure switch (model: psw521 by Omega Inc.). The signal requires an external calibration kit to correct its corresponding pressure value. The Cryo Area Trip function will close the LHe supply valve, cold and warm return valves and heater power if the pressure is more than 18.9 psia isolating He gas between the SRF module and the cryogenic system. In addition to the single fast pressure switch control, there is also a SPRING Relief Valve to release over-pressure within the vessel as shown in Fig. 8. For debugging and security requirements following a Cryo Area Trip, the trip signal will trigger the ready chain and latch on the state. The operator won't know the real recovery time of the Cryogenic system (the ready chain needs the whole system to recover to release the latch), and it would be necessary to display the actual status on-line and update the history records.

This requirement can be solved by adding a comparator after the Omron meter and use the no latch output contact as a new output. For Safety and redundant protection, the fast pressure switch and pressure transducer (px209-30psai) are serially connected in the SRF system of the TPS and RF lab. The design of the TLS system thus adds two sets of pressure sensors, one for an alarm call for staff to recover the TLS SRF system and the other for activating mechanical protection. Since the Cryo Area Trip panel can't be modified to add display LEDs for new pressure sensors, only a single mark is assigned on the system schematic.

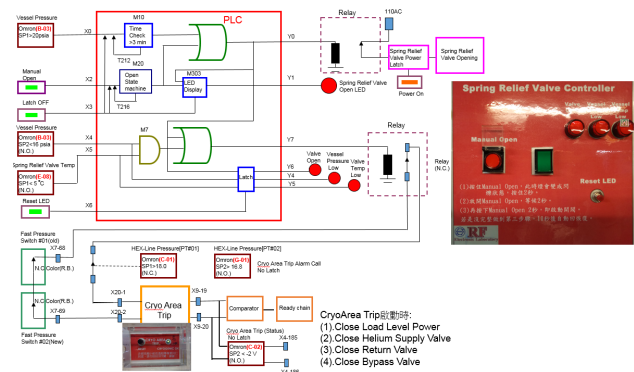

Figure 8: Control logic for the spring relief valve with a new pressure transducer in the TLS.

SUMMARY

After completion of the PID module update project at the TLS, the availability of spare parts can be extended by several years. With the upgrade of modern electronic components, the operation and communication interface is also changing. Choice and stability tests of the new modules are time-consuming work. To select a proper replacement while keeping, at the same time, the original system in operation without interruption continues to be an engineering challenge.

REFERENCES

[1] Ch. Wang *et al.*, "Operational experience of the superconducting RF module at TLS," *Physica C: Superconductivity*, Vol. 441, 2006, pp.277-281.
 [2] F.-T Chung *et al.*, "Design and upgrade of The SAFETY SYSTEM for the SRF electronic system at Taiwan Photon Source", in *Proc. IPAC'16*, 2016, paper MOPMY032, pp.567-569.

Copyright © 2017 CC-BY-3.0 and by the respective authors