

UPGRADE OF THE FERMILAB SPOKE TEST CRYOSTAT FOR TESTING OF PIP-II 650 MHz 5-CELL ELLIPTICAL CAVITIES*

A. Sukhanov[†], S. K. Chandrasekaran, C. Contreras-Martinez¹, B. M. Hanna, T. H. Nicol, J. P. Ozelis, Y. Pischalnikov, D. Plant, O. Prokofiev, O. Pronitchev, V. Roger, W. Schappert, I. Terechkine, V. Yakovlev, Fermilab, Batavia, USA
¹also at FRIB, East Lansing, USA

Abstract

Design of the high beta 650 MHz prototype cryomodule for PIP-II is currently undergoing at Fermilab. The cryomodule includes six 5-cell elliptical SRF cavities with accelerating voltage up to 20 MV and low heat dissipation ($Q_0 > 3 \cdot 10^{10}$). Characterization of performance of fully integrated jacketed cavities with high power coupler and tuner is crucial for the project. Such a characterization of jacketed cavity requires a horizontal test cryostat. Existing horizontal testing facilities at Fermilab, Horizontal Test Stand (HTS) and Spoke Test Cryostat (STC), are not large enough to accommodate jacketed 650 MHz 5-cell cavity. An upgrade of the STC is proposed to install extension to the cryostat and modify cryogenic connections and RF infrastructure to provide testing of 650 MHz cavities. In this paper we describe STC upgrade and commissioning of the upgraded facility. We discuss mitigation of issues and problems specific for testing of high- Q_0 650 MHz cavities, which require low residual magnetic field and low acoustic and mechanical vibrations environment.

INTRODUCTION

Fermilab builds Proton Improvement Plan II (PIP-II) project to deliver intense neutrino beam to LBNF/Dune experiment [1]. Superconducting RF (SRF) linac is the major part of PIP-II accelerator. It comprises five different types of SRF cavities, including Half-Wave resonators (HWR) at 162.5 MHz, two types of Single Spoke Resonators (SSR1 and SSR2) at 325 MHz and two types of 5-cell elliptical cavities, low- and high-beta at 650 MHz, (LB650 and HB650). Design of the first prototype HB650 cryomodule is nearing its completion. The cryomodule consists of six cavities providing accelerating voltage up to 20 MV with low heat dissipation, $Q_0 > 3 \cdot 10^{10}$. It is extremely important for the successful cryomodule construction to characterize performance of fully dressed HB650 cavities assembled with high power coupler and tuner in a horizontal test facility. Because of its large size, jacketed 5-cell cavity does not fit into Fermilab Horizontal Test Stand (HTS) and Spoke Test Cryostat (STC). We propose upgrade of STC, which includes installation of the STC vacuum vessel extension with magnetic and thermal shields, modifications of cryogenic connections and RF infrastructure to accommodate testing of 650 MHz cavities, while also retaining capability of testing SSR1 and

SSR2 cavities. In the following sections we describe design of the STC upgrade and ongoing activities of installation and commissioning of the upgraded facility. Testing of high- Q_0 cavities requires low residual magnetic field and low acoustic and mechanical vibrations environment. We discuss efforts to mitigate these issues.

DESIGN OF THE STC UPGRADE

Figure 1 shows original STC facility in configuration for testing SSR1 cavities. Stainless-steel vacuum vessel (VV) has two hinged dome doors on each side providing access for cavity installation. Magnetic shield is located at the inner surface of VV. Thermal shield is actively cooled with liquid Nitrogen at 80 K. Cool down/warm up line comes from the top the vessel. Two-phase pipe is located above cavity. It has a canister welded at one end for liquid Helium level and temperature instrumentation. Cavity support post attached to VV and thermal shield, with provision of thermal intercept at 80K to reduce heat load.

For radiation safety purposes STC resided inside of an enclosure built out of concrete blocks. An access to enclosure is provided through a labyrinth corridor, which is only 35 inch wide in its narrowest part. Picture on the left side of Fig. 1 is taken from the entrance to the STC enclosure. Cryogenic connection lines located directly above STC and HVAC and Oxygen Deficiency Hazard ventilation systems atop of the far side of the STC enclosure roof limit use of the building overhead crane, complicating assembly and installation of upgraded components.

The original STC vacuum vessel is 39.5 inch long, while HB650 cavity length is approximately 55 inch. In order to accommodate longer cavities, we add extension to the STC VV equipped with its own magnetic and thermal shields, and cavity support post as shown in Fig. 2. Extension sits on a separate support post. It is bolted to the far end of STC in place of the dome door, which is re-hinged at the end of VV extension.

To accommodate longer 650 cavity, two-phase pipe is elongated, Fig. 3. It re-uses instrumentation canister and cryogenic system/SSR1 interface cross-part of the original pipe and adds longer horizontal pipe with thermal intercepts for coupler and interface for connection to 650 cavity chimney/Helium vessel. Due to its size, new 2-phase pipe requires support at the canister side.

Upgraded STC configuration for testing 650 cavities is shown in Fig. 4. An aluminum platform with a rail is set on top of the two support post inside VV, bolted to one post

* Work supported by D.O.E. Contract No, DE-AC02-07CH11359

[†] ais@fnal.gov

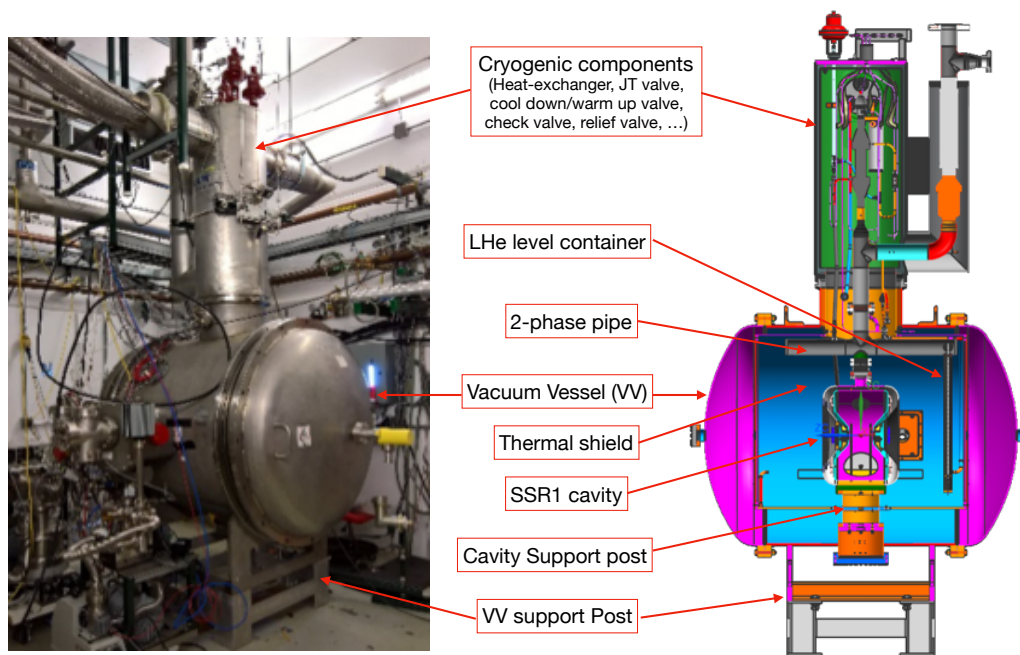

Figure 1: Original Spoke Test Cryostat (STC) facility in configuration for testing SSR1 cavities.

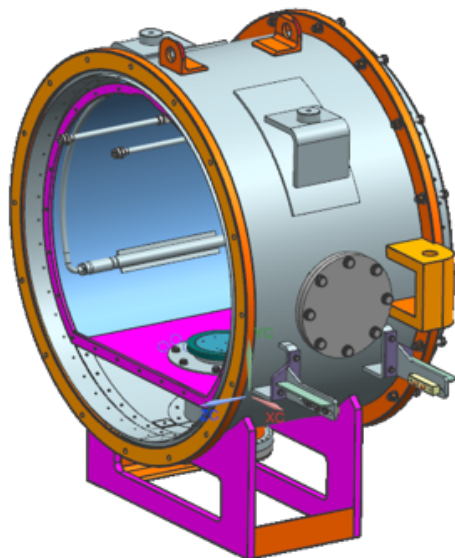

Figure 2: STC extension.

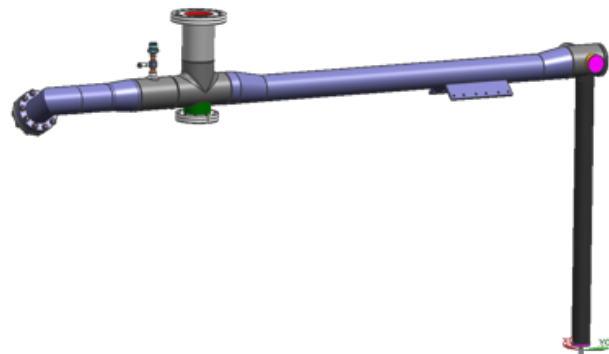

Figure 3: 2-phase pipe.

INSTALLATION AND COMMISSIONING

Design of the STC upgrade has been completed in the Summer 2017 and purchasing orders have been placed for major components in the Fall 2017. All components have been received at Fermilab in Summer 2018. By that time STC was occupied by the SSR1 test program [2]. After successful completion of SSR1 testing, we started installation of new components at the end of 2018.

By the end of June 2019, we have finished mechanical assembly of the STC upgrade. At the time of writing this paper we commission STC cryostat and getting ready for first cooldown.

In this section we describe installation and commissioning of the STC upgrade. We focus on discussion of various issues encountered during the upgrade.

and capable of sliding over a Teflon insert at the second post. Figure 4 top right shows HB650 cavity assembled with cold part of high power coupler, tuner, magnetic shield, liquid Helium fill line and interface elbow for two-phase pipe mounted at the aluminum insertion cart on top of the installation table. After cavity preparation outside cryostat is complete, it slides together with the insertion cart inside the vacuum vessel, bottom part of Fig. 4.

Figure 5 demonstrates configuration of upgraded STC for testing of SSR cavities. In this configuration the aluminum platform is removed from the support posts. SSR cavities are inserted inside VV using existing tooling.

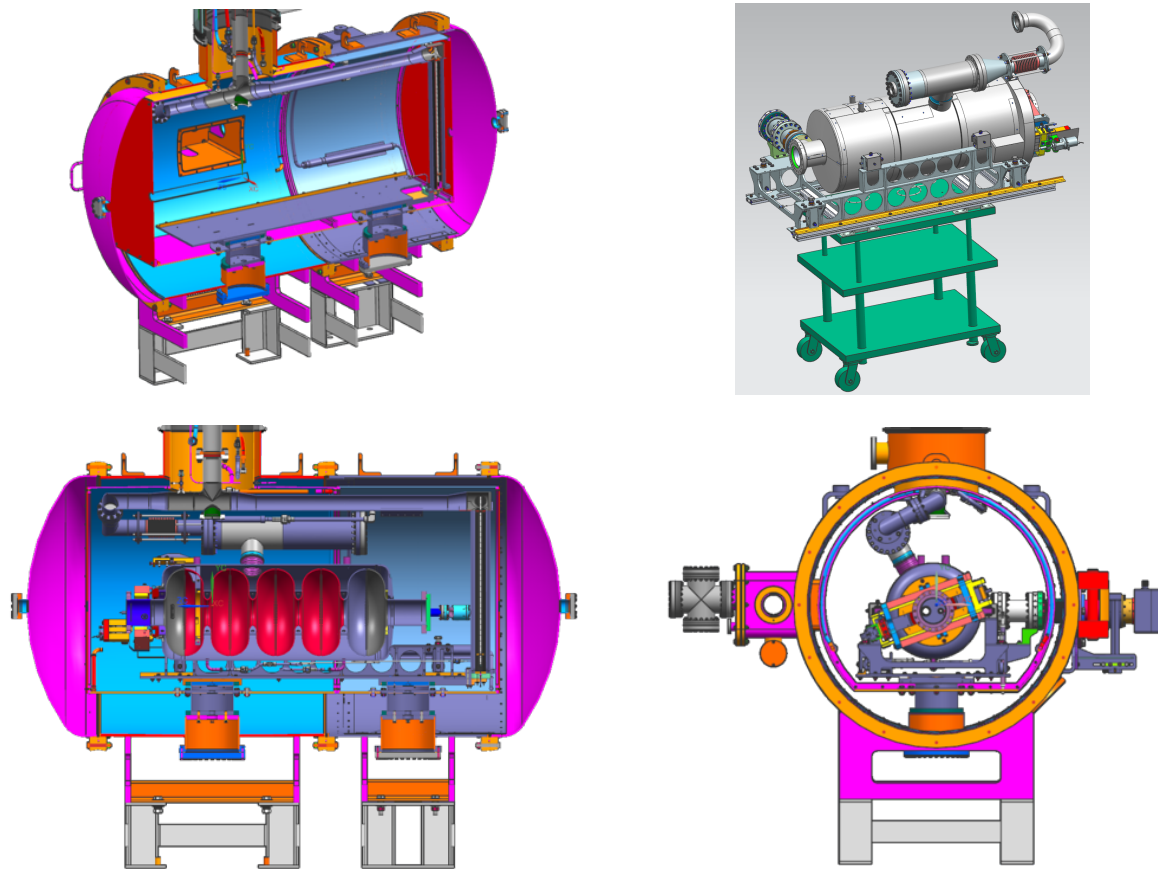

Figure 4: STC in 650 MHz testing configuration.

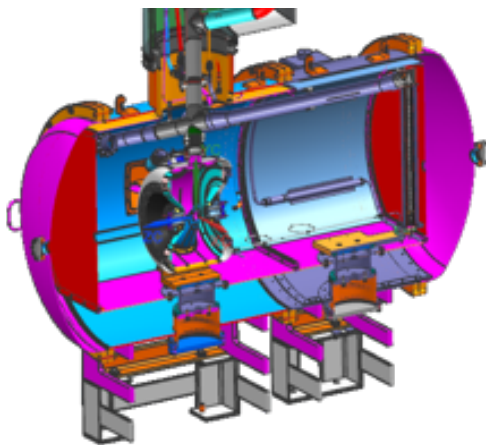

Figure 5: STC in SSR1 testing configuration.

Installation

As one of us (T.H.N.) has mentioned, STC, which started its life many years ago as a test cryostat for testing superconducting magnets at a different location in Fermilab, is now living its 9th life.

Mechanical design of the STC upgrade components is essentially based on 3-D models, which were built from older drawings. While the cryostat, which eventually become STC, was modified multiple times during the course of its service

life, not all details of these modifications got captured into models. This created issues with fitting of the new parts to the older parts of STC during installation, required “dry”-fitting of all parts and additional mechanical work on mis-fit parts and caused delays in installation and completion of the project.

An example of such mis-fit are holes at the large flanges of VV extension. These flanges interface with the old STC vacuum vessel and dome door and have 16 holes in them. While the hole pattern comply with drawings generated from 3-D models, “dry”-fit of the real dome door to extension reveal misalignment of some holes by as much 1/8 inch.

Another example is the extension magnetic shield. The shield consists of two semi-cylindrical parts, joined at the bottom and the top inside of the extension vacuum vessel to form the complete cylindrical shield. The shield semi-cylinders designed for a snug fit around the cavity support post flange at the bottom of the vessel. There is a 1/4 inch wide welding seam at the flange-vessel joint, which bulges under shield semi-cylinder at the bottom and makes them to overlap with 1/2 inch excess at the top.

Cryogenic hoses interconnecting nitrogen cooling lines between thermal shields and providing connection to the supply/return lines needed to be re-worked to avoid too much slack or too tight stretch.

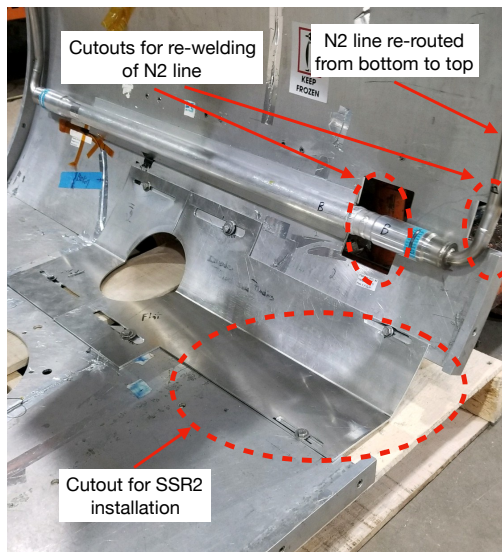

Figure 6: Modifications to the original STC thermal shield.

Initial design of the STC upgrade in 2017 did require any modifications to the original STC thermal shield. While finalizing mechanical design of SSR2 cavity at the end of 2018, we realized that a cutout in the thermal shield needs to be made and nitrogen cooling line needs to be re-routed from the bottom of the shield to the top to provide space for installation of SSR2 cavity into STC, see Fig. 6.

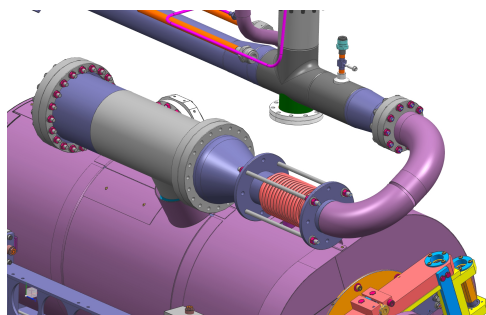

Figure 7: Re-designed interface between two-phase pipe and 650 cavity.

Due to very tight space limitation we use mitter elbows in design of the interface between 650 cavity and two-phase pipe, which is visible in Fig. 4, bottom. This design has been reviewed and approved by the Fermilab cryogenic safety committee in 2017. In April 2019 we became aware that mitter elbows are not compliant with safety code for certain cryogenic piping. We re-design interface using radius elbows as shown in Fig. 7.

Commissioning

After assembly of the STC cryostat extension and internal plumbing we perform leak check. Vacuum vessel is evacuated. With reduced pumping power, operating only one out of three available vacuum pumping stations, we are able to reach 3–4 μm of the cryostat insulating vacuum. Helium background is better than 10^{-8} Torr-l/s and does not fluctuate

much when we spray outside of the cryostat with Helium gas or pressurize Helium and Nitrogen lines inside cryostat to 5 psi with Helium.

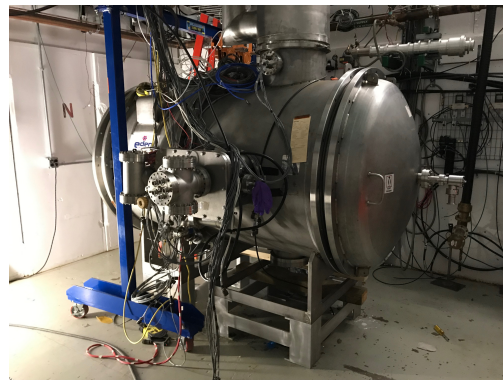

Figure 8: STC cryostat upgraded for testing of 650 MHz cavities: completely assembled, leak checked and Helium and Nitrogen circuits pressure tested. Ready for commissioning cool down.

In compliance with safety requirements we perform pressure tests of newly installed pipes. We use Nitrogen gas from bottle and pressurize two-phase pipe to 65 psig, while thermal shield Nitrogen cooling lines are pressurized to 90 psig. Since no leaks detected and pressure remain stable during these tests, we declare pressure tests successful and STC piping ready for safe cryogenic operation. Figure 8 shows STC cryostat assembled.

As a final step in commission of the STC before cooling down actual cavity, we prepare 0-cavity test. For such a test, cool down line is connected only to the instrumentation canister of the two-phase pipe, cavity connector at the cool down line and cavity interfaces at two-phase pipe are cupped. We install instrumentation to measure thermal behavior of the shield, piping and support structures inside cryostat. Figure 9 shows inside of the STC cryostat prepared for commissioning cool down. We expect to perform this test and report results by the end of June 2019.

First prototype HB650 cavity has been jacketed at Fermilab. Preparation is ongoing for assembly of the cavity with high power coupler and tuner. We plan to bring this cavity to STC and start installation for the test in July 2019, pending readiness of 650 MHz high power RF distribution system.

MITIGATION OF ENVIRONMENTAL ISSUES

Preservation of high intrinsic Q_0 of 650 MHz cavities requires their operation in low residual magnetic field and low acoustic and mechanical vibrations environment.

Magnetic shielding of the STC cryostat is essential. Simulation and direct measurements [3] show that with the shield residual field of 10–15 mG can be reached inside STC. Estimation of [4] show, that residual magnetic field at the external cavity surface should exceed 5 mG, therefore both LB650 and HB650 cavities are also equipped with individual



Figure 9: Inside of the upgraded STC cryostat: prepared for commissioning 0-cavity cool down.

magnetic shields. While installing components of the STC upgrade, we pay attention to magnetic hygiene, carefully measuring magnetization of installed parts and hardware and demagnetizing, when needed. Preliminary measurements of residual magnetic field inside STC vacuum vessel without endcup magnetic cones installed, show that field at the cryostat axis between cavity support posts varies in the range 15–40 mG, with higher values above posts, closer to the unshielded ends of the cryostat and smaller values in the middle of the cryostat. We plan to perform more accurate evaluation of residual magnetic field inside STC cryostat with endcup shielding installed after 0-cavity cool down.

Acoustical and mechanical vibrations and noise (so called “microphonics”) are one of the factors limiting performance of narrow bandwidth SRF cavities, such as HB650. Microphonics require mitigation at environmental level and at the level of the cavity resonance control system (LLRF). From our experience at STC during SSR1 program we know that the worst noise level can be as high as 200 Hz. We associate this large level of microphonics with the noise due to cryogenic system. After installation of STC vacuum vessel extension while cryogenic system is still shutdown and physically disconnected from the cryostat, we perform evaluation of mechanical vibrations in the STC enclosure and inside vacuum vessel. We do not find significant noise. We plan to continue evaluation of microphonics during 0-cavity cool down and subsequent testing of HB650 cavities.

CONCLUSION

We present upgrade of the Fermilab STC horizontal testing facility which enables us to test and characterize fully integrated 650 MHz cavities for PIP-II project. We complete installation of the STC upgrade and prepare cryostat for commissioning and 0-cavity cool down. We describe various problems encountered during installation of the STC upgrade project. Finally, we discuss mitigation of environmental issues relevant to testing of high- Q_0 narrow bandwidth cavities, such as HB650.

REFERENCES

- [1] V. Lebedev *et al.*, “PIP-II Reference Design Report”, http://pxie.fnal.gov/PIP-II_RDR
- [2] A. Sukhanov *et al.*, “Characterization of SSR1 Cavities for PIP-II Linac”, presented at the SRF’19, Dresden, Germany, Jun.-Jul. 2019, paper THP090.
- [3] Y.Terechkine, Private communication
- [4] M.Martinello, Private communication