

MODULAR LOGARITHMIC AMPLIFIER BEAM POSITION MONITOR READOUT SYSTEM AT THE UNIVERSITY OF HAWAII*

B. T. Jacobson, M. R. Hadmack, J. M. J. Madey, P. Niknejadi

Department of Physics & Astronomy, University of Hawai'i, Honolulu, HI 96826, USA

Abstract

High brightness electron beams for inverse Compton photon sources driven by thermionic microwave guns require real-time position measurements in order to achieve the spatial and temporal coincidence necessary to ensure statistically measurable signals. True logarithmic amplifiers are more adequately suited to signal comparison than are sigma-delta methods. A low-cost, modular and scalable readout and data acquisition system for strip-line beam position monitors utilizing the AD640 log-amp is being developed at University of Hawai'i MkV Linear Accelerator and Free Electron Laser Lab. Initial measurements and prototyping of the hardware is complete with commissioning and deployment of the system currently ongoing. We present the methodology and early results of this project.

INTRODUCTION

The University of Hawai'i (UH) MkV Linear Accelerator facility and Free Electron Laser (FEL) Lab utilizes a thermionic LaB₆ cathode electron source in a microwave gun injector followed by a single section of traveling wave S-Band linear accelerator to produce a ~ 200 mA average macro-pulse current 40 MeV electron beam. This beam drives a hybrid NdFeB planar undulator and Michelson interferometer phase-locked resonator based infrared FEL. Constructed on UH campus and occupying roughly one-third of the first floor of the physics department, the accelerator beamline was commissioned by 2009 and the lab produced first laser light in 2010; current experiments are focused on initial demonstration of inverse Compton x-ray photon production via FEL laser output and electron beam collision. A pico-second resolution x-ray detector and multi-gigabit per second sampling electronics are also being developed in parallel by collaborators in the University of Hawai'i Instrumentation Development Lab (IDLab) for measurement of the resulting micro-bunch x-ray train.

The electron beam transport system configuration for these experiments requires strong focusing to achieve small transverse size of the e-beam (and similarly for the optical beam used in the collision) in order to achieve optimum x-ray flux. One of the machine upgrades underway in support of the objective of a well-centered beam in the quadrupole magnets of the transport system and measurement of the electron beam transverse position for injection into the x-ray interaction point (IP) is the instrumentation

of the beam position monitors (BPM's) installed along the UH MkV beamline.

Two varieties of BPM's are installed along the MkV beamline, a stripline type and a wall current variety. The stripline BPM's (shown installed on beamline in Fig. 1) consist of a stainless steel body with four copper electrodes oriented with $\frac{\pi}{2}$ symmetry mounted on standard $2\frac{3}{4}$ inch conflat flanges and are surplus from the SPEAR project at SLAC[1]. These stripline BPM's are installed in four locations along the diagnostic chicane transport system, which transports the e-beam from the linac to the FEL, as well as injects the e-beam into the scattering chamber where the x-ray IP is located.

The so-called "tin-can" wall current BPM's contain an FR-4 printed circuit board (PCB) sandwiched between a pair of conflat-type knife edge flanges that make vacuum seal against the copper plating on the board, routed with traces which carry induced wall current at four cardinal positions around the beam pipe with a minimum of temporal distortion to a 4-port connector block at the perimeter of the PCB. A suitably placed toroid provides a large inductance that forces all of the image currents that otherwise might flow along the outside of the beam pipe to instead flow along the impedance-matched PCB traces, insuring that all the components of the wall currents so sampled will emerge on the inner conductors of the coaxial output ports of the BPM. The frequency response of these wall current BPM's is nearly flat from below 100 kHz to beyond 20 GHz. Figure 2 shows one of the two wall current beam position monitors that have been installed in the MkV beamline (one at the linac output and one at the input to the FEL). Further description of these devices will be published separately.

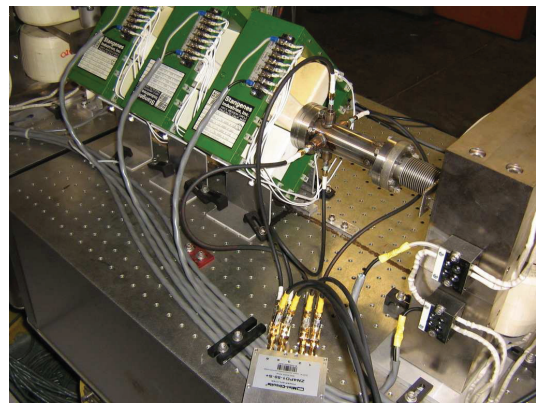

Figure 1: Stripline BPM installed on University of Hawai'i MkV FEL beamline.

* Work supported by DHS Agreement Number: 2010-DN-077-AR1045-02, Amendment 2

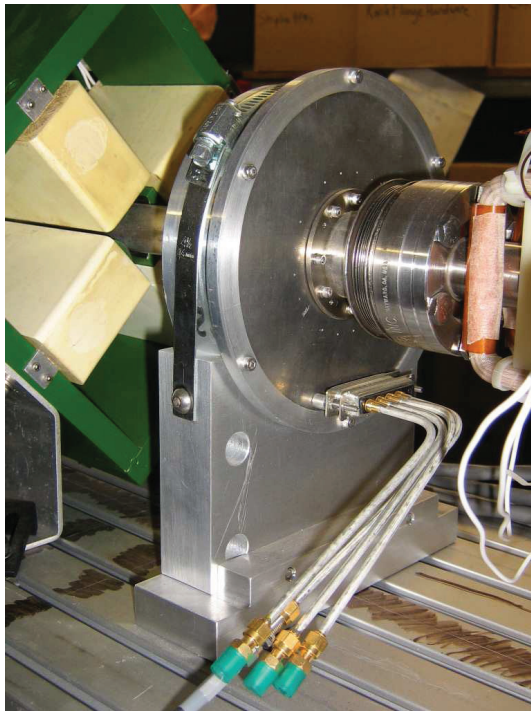

Figure 2: Photo of the so-called “tin-can” wall current beam position monitor installed in two locations on the University of Hawai’i MkV FEL beamline.

BPM SIGNAL READOUT SCHEME

The timing structure of the accelerated electron beam exhibits both a micro-pulse and a macro-pulse structure. The short micro-pulses are a result of the thermionic microwave electron gun source filling each RF bucket in the linac and the temporal compression imparted by an alpha-magnet [2] integrated into the injector system. In practice, the alpha magnet field gradient and S-band drive frequency of 2.856 GHz yields 1-2 ps long micro-pulses separated by 350 ps. High power RF is applied to the accelerator and microwave gun for a macro-pulse length of 4.5 μ s at a 4 Hz repetition rate duty cycle. This micro-bunching in the electron beam produces strong signal at the accelerator RF frequency in both types of BPM’s.

In order to avoid the usual difficulties in BPM signal comparison (namely the phase match required to directly compare two RF voltages, detector and electronics lifetimes in intense radiation fields found near the beamline, and signal degradation and loss in long cables) the readout strategy is to mix the BPM signals with a local oscillator RF reference in the accelerator vault, resulting in an intermediate frequency (IF) between 10 - 20 MHz. The IF signal from each output port of each BPM is carried through long runs of LMR-400 coaxial cable from the accelerator vault to the operator control room.

The Analog Devices AD640 logarithmic amplifier serves as both the detector used to measure the mixer outputs for each BPM port as well as the means to provide

an essential mathematical operation in the signal comparison chain. The log-amp and supporting circuitry are implemented in a modular way on pluggable cards with a compatible multiple slot chassis that provides for system expansion, component replacement, and maintenance access. The data acquisition (DAQ) system collecting the position signals derived from the log-amp detector cards consists of a dedicated analog to digital converter (ADC) and a computer display in the operator control room.

BPM SIGNAL HETERODYNE SYSTEM

The beam position monitor readout system utilizes heterodyne mixing of the raw BPM outputs in order to convert the strong 2.856 GHz signal to the more manageable HF-Band. A sample BPM output signal chain is shown in Fig. 3, which is repeated for each output of each BPM. All connections are SMA and components are in-line devices, as seen installed in Fig. 1.

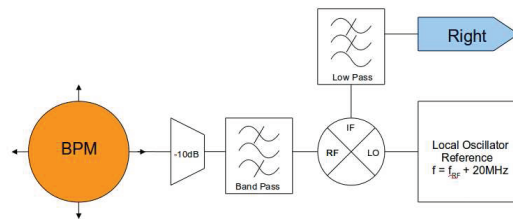

Figure 3: Block diagram of heterodyne concept for typical BPM signal channel.

A 50 Ω 10 dB attenuator helps to provide an impedance match between the stripline electrodes and the signal cables and other components (not required for the tin-can wall current BPM’s which have internal 50 Ω stripline traces). A band pass filter (Mini-Circuits VBF-2900+) ensures that no higher order harmonics (for stripline BPM’s) and other frequency components down to DC (for wall current BPM’s) enter the doubly balanced mixer (Mini-Circuits ZX05-42MH-S+). Any high frequency leakage out of the mixer is blocked by the low pass filter (Mini-Circuits VLF-190+) on the mixer IF port.

Each mixer requires +13 dBm (20 mW) input to the local oscillator port close to the accelerator frequency, and therefore a local oscillator (LO) distribution network is being assembled, which is capable of delivering the +19 dBm of power to each BPM mixer station. A 4-port power splitter (Mini-Circuits ZN4PD1-50-S+) divides the LO at each BPM mixer station to each of the four mixers. Additional power splitters will distribute the LO to each BPM, with the reference provided by a single HP-8616A RF signal generator followed by a 40 dB amplifier (Mini-Circuits ZHL-4240).

BPM LOGARITHMIC AMPLIFIER READOUT SYSTEM

The IF mixer output signals from each beam position monitor are transmitted over long cables from the accelerator vault to a patch panel in the operator control room. The readout electronics for each BPM are implemented on a dedicated PCB card which is installed into the readout system chassis slots via a 44-contact card-edge connector. Each PCB card has four input channels, and hence is capable of instrumenting a single beam position monitor.

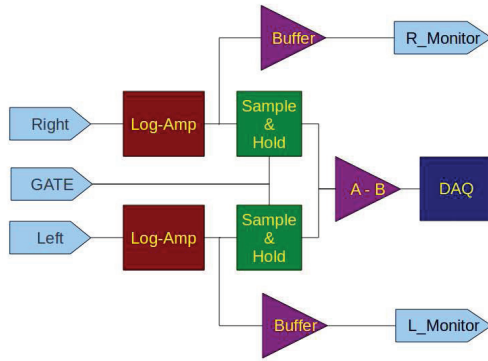

Figure 4: Block diagram of ESMAROLDA beam position monitor readout cards.

A simplified block diagram for calculating the beam position in one coordinate plane (in this case, the horizontal position) is shown in Figure 4. The log-amp block contains the AD640 logarithmic amplifier and the 60 MHz bandwidth fast slewing AD844 op amp current to voltage buffer circuit. The transfer function of the log-amp block is:

$$V_{out} = V_{slope} \log \left(\frac{V_{in}}{V_{ref}} \right), \quad (1)$$

where the constants V_{slope} and V_{ref} are controlled, trimmed, and set at the chip foundry to be uniform among devices. Each log-amp output voltage signal is buffered and sent to a monitor card for time-resolved signal monitoring.

The sample and hold block (S&H) consists of an externally gated analog switch (Fairchild CD4066) and low-leakage polypropylene film capacitors. The external gate is generated by a Berkeley Nucleonics Model 505 gate and delay generator and timing governed by the electron beam master trigger. A programmable gain difference amplifier compares the DC signals present on the S&H output and derives the position error signal. The transfer function of the difference amplifier is:

$$V_{out} = G \times (V_{out}^R - V_{out}^L), \quad (2)$$

where the sensitivity G is adjusted by changing the plug-gain resistors on the PCB. The transfer function at

the output of the difference amp (combining Eq. 1 and Eq. 2) is:

$$V_{out} = G \times V_{slope} \log \left(\frac{V_{in}^R}{V_{in}^L} \right), \quad (3)$$

which necessarily vanishes for a centered electron beam.

A BPM detector card PCB known as Electron Stripline Monitor Analog ReadOut Log-Difference Analyzer (ESMAROLDA) containing two copies of the circuit indicated in the block diagram has been designed, prototyped, tested, and finalized in a production run. Initial bench test results are shown in Fig. 5 and in Fig. 6. In each case, a 20 MHz signal source is divided by a balanced 2-way 3 dB power splitter with one output sent directly to an ESMAROLDA input and the other splitter output being passed through a variable attenuator before connection to the opposing ESMAROLDA input channel. Testing shows a logarithmic response from the log-amp and correct overall transfer function and position error signal output.

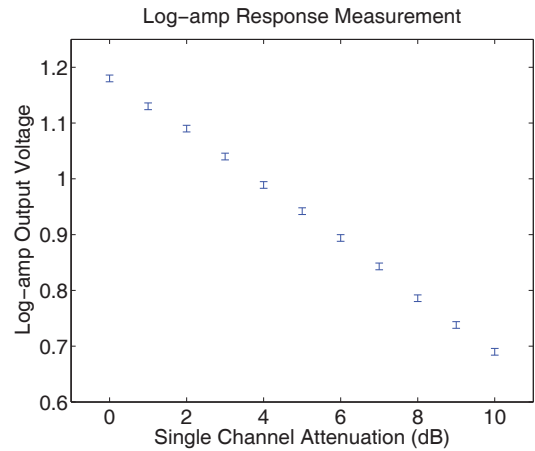

Figure 5: Response of typical BPM signal detector circuit, AD640 log-amp and AD844 current to voltage buffer, as a linear function of input attenuation.

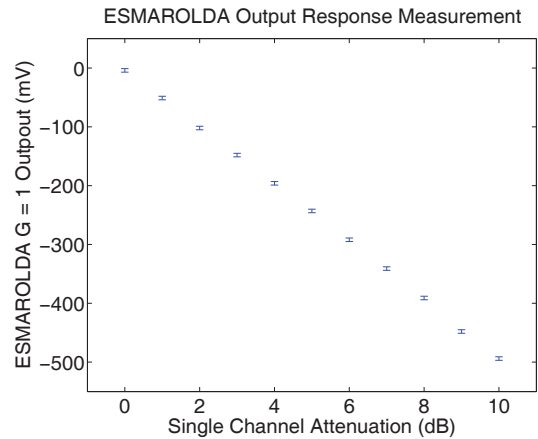

Figure 6: Output response of typical horizontal or vertical plane signal comparison circuit as a linear function of single channel input attenuation.

BEAM POSITION MONITOR GRAPHICAL USER INTERFACE

The purpose of the Beam Position Monitor Graphical User Interface (BPM-GUI) is to provide an interactive tool for the BPM hardware and software system. The BPM mixer stations and detector cards readout the beam offset, in both x and y directions, as a positive or negative voltage. The BPM-GUI is part of the DAQ system and displays these voltages in the control room where the accelerator operator can use the BPM-GUI readout to center the e-beam by adjusting the beam transport system as to null the readouts.

The BPM hardware interface is the 14-channel ADC in a LabJack UE9. The LabJack UE9 has all analog input (AIN) channels on its DB37 connector, which mates with a custom cable from the BPM patch panel chassis, and is used to read the horizontal and vertical offset signals from each BPM. The nominal input range for each AIN is ± 5 volt. When using several channels at once there is a 12 microsecond delay for 12 bit-streaming from channel to channel. The pulse rate in the accelerator is 5Hz. For accurate readouts the BPM GUI is set to read every 100ms (meeting the minimum of 2 readout per cycle). Hence the delay in the channel readouts can be neglected.

The LabJack software (LabJackPython) was implemented in the GUI code written in wxPython to provide the first version of BPM-GUI, shown in Fig. 7. Currently this development version of the BPM-GUI only provides the readout for each BPM in volt (using read only display text boxes). The button “Read Once” retrieves the voltages only once as a test at the start of the run and the “Read Continuously” retrieves and displays the voltages until the program is stopped. The “Restart” button zeros all the entries and is only functional when the program is not in continuous run mode. The “Exit” button stops the reading and closes the BPM-GUI.

Upon complete installation each BPM will be renamed to identify its position along the beamline. Finally the next version of the BPM-GUI will have a bullseye display for each BPM that will illustrate for the operator how off-center the beam is and will facilitate the centering process and also display a graphical illustration of the electron beam centroid’s evolution along the length of the machine.

EARLY BEAM TEST MEASUREMENTS

Unexpected machine down-time, maintenance, and a partially assembled local oscillator network have postponed full-up operation of the BPM readout system, however initial testing has been preformed using the fully assembled chassis and signal cable network with one BPM active at a time, for each of the stripline and wall current varieties.

Beam test was done with a single stripline BPM located downstream of the first bend magnets in the MkV diagnostic chicane. The accelerated beam parameters for the run were 170 mA average macro-pulse current and a beam

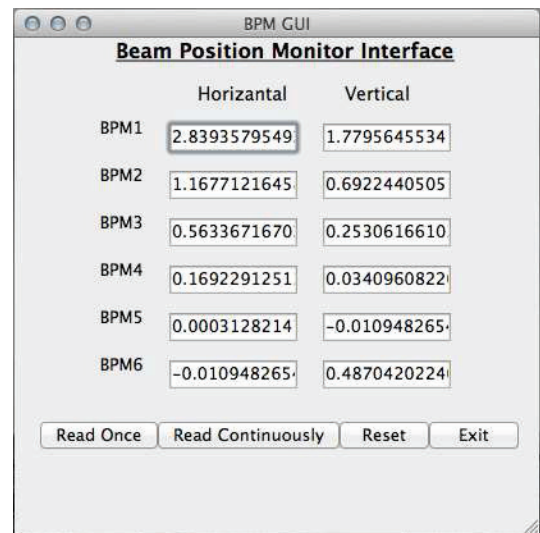

Figure 7: Screen shot of BPM GUI display.

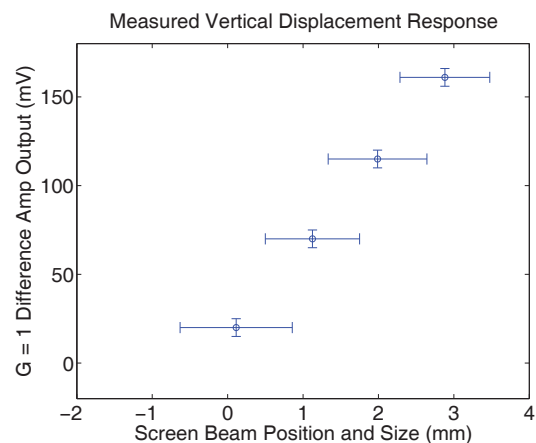

Figure 8: BPM readout response as a function of vertical electron beam position (with beam size shown by horizontal error bars) on downstream transition radiation screen.

energy of 37 MeV. The beam was imaged on a copper transition radiation (TR) screen downstream of the beam position monitor and centered in the beamline quadrupoles (and therefore roughly centered in the BPM) by minimization of beam deflection from increase in quadrupole gradient. The beam was then given kicks independently in both the vertical and horizontal directions upstream of the BPM and offset voltages from the readout system recorded. In this instance, the difference amplifier gain is set to unity.

By knowing the pixel to size calibration for the recorded TR screen images, the beam displacement can be calculated. Figure 8 shows the BPM readout offset signal as a function of the measured beam position at the screen. The beam centroid offset is estimated by simple geometric means from the relative location of the dipole kicks, BPM, and TR screen and plotted in Fig. 9.

After testing the stripline BPM, the LO was moved to one of the wall current BPM’s and the accelerator restarted.

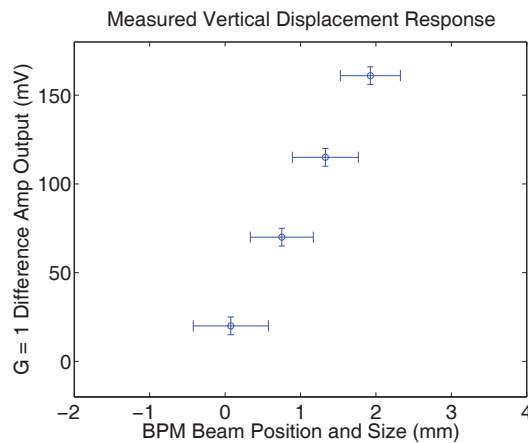

Figure 9: BPM readout response as a function of estimated electron beam position (with beam size shown by horizontal error bars) at BPM location.

Testing demonstrated that signal levels were more than adequate to measure, however it was also discovered that the angular orientation of the BPM as presently installed is skewed by a large angle from the vertical and horizontal directions in the lab. Once this rotation is corrected, the system will be re-evaluated.

SUMMARY

We have constructed a modular logarithmic amplifier beam position monitor readout system at the University of Hawai'i MkV Linear Accelerator and Free Electron Laser Lab and tested this system on both a stripline BPM and a "tin-can" wall current BPM. Favorable initial results have been met and final commissioning of the system for readout of all 6 BPM's expected in October. A basic graphical user interface is available with a clear upgrade and development path outlined.

ACKNOWLEDGMENT

We would like to acknowledge the dedication, cooperation, and support of the rest of the UH FEL group members: J. M. Kowalczyk, E. B. Szarmes, and I. Howe. Additionally we would like to thank our collaborators in the UH IDLab: G.S. Varner, M. Z. Andrews, and K. Nishimura.

REFERENCES

- [1] Chang, A K and Kang, H K and Larsen, R S, "Position and Intensity Monitoring System for the SPEAR Transport System at SLAC," PAC'73, San Francisco, March 1973, p. 624
- [2] John M. J. Madey and Glen A. Westenskow, "Microwave Electron Gun," United States Patent 4,641,103 (1984)