

RF FRONT END FOR HIGH BANDWIDTH BUNCH ARRIVAL TIME MONITORS IN FREE-ELECTRON LASERS AT DESY

A. Penirschke[#], A. Angelovski, M. Hansli, R. Jakoby, Institut für Mikrowellentechnik und Photonik, TU Darmstadt, Darmstadt, Germany

C. Sydlo, M. K. Czwalinna, M. Bousonville, H. Schlarb, DESY, Hamburg, Germany

A. Kuhl, Universität Hamburg, Institut für Experimentalphysik Gruppe Beschleunigerphysik, Hamburg, Germany

S. M. Schnepf, Laboratory for Electromagnetic Fields and Microwave Electronics, ETH Zürich, Switzerland

T. Weiland, Institut für Theorie Elektromagnetischer Felder, TU Darmstadt, Darmstadt, Germany

Abstract

High gain free-electron lasers (FELs) can generate ultra short X-ray pulses in the femtosecond range. For a stable operation of the FEL, the precise knowledge of the bunch arrival time is crucial. The bunch arrival time monitors (BAMs) at FLASH achieve a resolution less than 10 fs for bunch charges higher than 500 pC which is sufficient for the beam based stabilization system of the Free-Electron Laser in Hamburg FLASH [1]. Increased demands for low bunch charge operation mode down to 20 pC at FLASH II and the European X-ray free-electron laser XFEL require an upgrade of the existing beam diagnostic equipment. A new high bandwidth BAM with new developed cone shaped pickups [2] promises sub-10 fs resolution for both, the high and low bunch charge operation mode. This paper addresses the RF signal path of the high bandwidth BAMs for FLASH II and XFEL. It comprises radiation resistant coaxial cables, combiners and limiters up to a frequency of 40 GHz from the pickup electrodes to the Mach Zehnder Modulator (EOM). Detailed investigations of the signal path using measurements and simulations with AWR Microwave Office allows for a good prediction of the signal quality and shape at the EOM.

INTRODUCTION

In order to achieve femtosecond stability in the synchronization process, the Free Electron Laser in Hamburg (FLASH) is equipped with Bunch Arrival-time Monitors (BAM) which are part of the electro-optical detection system [1]. The BAM comprises an RF-pickup, an electro-optical front-end and read-out electronics [3].

The resolution of the BAM is proportional to the slope steepness at the zero crossing of the pickup signal [4]. The slope steepness is a function of the peak-to-peak voltage and the duration of the voltage response. These two parameters are related to the geometrical parameters of the pickup structure such as the diameter of the cone-shaped pickup and the diameter of the cut-out.

*Work supported by the Federal Ministry of Education and Research (BMBF).

[#] penirschke@imp.tu-darmstadt.de

CONE-SHAPED PICKUP DESIGN

In [5] a cone-shaped pickup was introduced which allows the detection of the arrival time with sub-fs resolution for the low charge operation mode in FLASH II and XFEL. The simulated BAM pickup system has a slope at the zero crossing of approximately 382 mV/ps and operates in the frequency range of DC - 40 GHz. Figure 1 shows a sketch of the cross-section of the cone-shaped pickup.

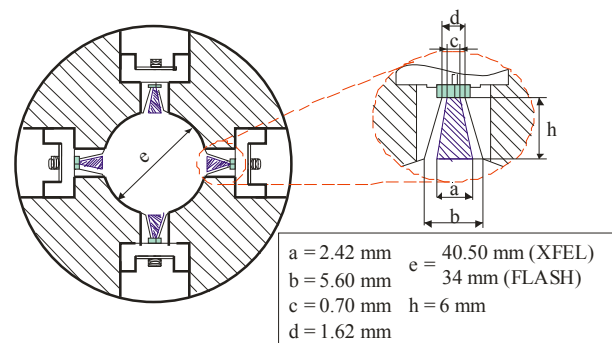

Figure 1: Cross-section of the cone-shaped pickup [5].

The cone represents a continuous transition from the button to the pin of the connector matched to the cable impedance of 50 Ω .

BAM RF-FRONT END

Due to higher operation frequencies the RF front end of the current BAM needs to be upgraded for the high bandwidth BAM. A sketch of the proposed RF front end is shown in Figure 2.

For high- and low-charge operation, two different channels are necessary. The low charge and the high charge channel consist of two opposite arranged pickups (either horizontally or vertically arranged) which are connected to a combiner via phase-matched rf-cables.

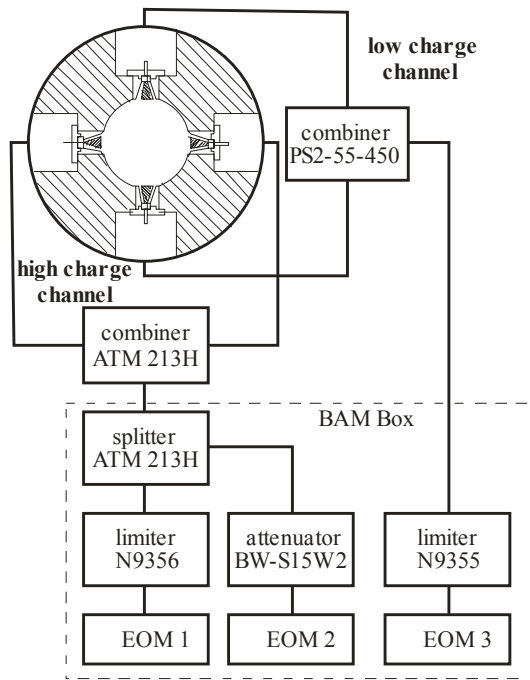

Figure 2: Proposed cabling plan and components for the 40 GHz BAM.

The combiner, a Multi-Wilkinson type from Pulsar Microwave (Type PS2-55-450) ensures a maximum phase difference of 8 degrees at 40 GHz between both input ports. The limiter Agilent N9355 (10 dBm, up to 50 GHz) protects EOM 3 from overvoltage in the high charge operation mode. The low charge channel operates up to 40 GHz.

For high charge operation a bandwidth of 13 GHz is sufficient to observe sub-10fs accuracy. Two different EOMs are proposed for the coarse and fine channel. The combiner and splitter are ATM 213H, which ensure a maximum operation frequency of 20 GHz and a maximum phase difference of 2.5 degrees. The limiter Agilent N9356 (26 dBm, 26 GHz) protects EOM 1 of the fine channel. The coarse channel also consists of a variable attenuator to adjust the slope at EOM 2.

To ensure a proper operation of the RF front end, the S-parameters of all components were measured prior to the installation.

Low Charge Channel Components

To combine the pickup signals a Multi-Wilkinson type combiner from Pulsar Microwave (Type PS2-55-450) was chosen. The measurement results, shown in Figure 3, exhibit reflection coefficients S_{11} less than -12 dB in a frequency range from 3 GHz up to 40 GHz and transmission coefficients S_{21} of less than -6 dB up to 40 GHz for both components. The combiner show a low pass characteristic with -10 dB at 45 GHz.

The limiter N9355C from Agilent technologies was chosen, since it offers a bandwidth up to 50 GHz with an acceptable power threshold of 10 dBm. The measurement results displayed in Figure 4, exhibit reflection coefficients

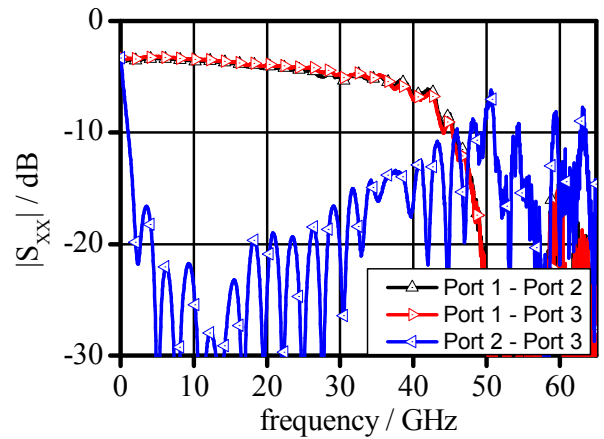

Figure 3: Transmission and reflection coefficient versus frequency of the RF-combiner PS2-55-450.

S_{11} less than -10 dB up to 52 GHz and transmission coefficients S_{21} better than 3 dB up to 40 GHz and better than -4 dB up to 50 GHz. The transmission factor of both devices is approximately linear up to 50 GHz.

High Charge Channel Components

The high charge channel comprises a much lower bandwidth up to 13 GHz so that a combiner with a cutoff frequency of about 20 GHz is sufficient. Here the combiner ATM 213H was chosen since it is already in use in the RF front end of the current BAMs. The transmission coefficient, shown in Figure 5, exhibits a flat frequency response up to 20 GHz and an acceptable transmission up to 32 GHz.

The reflection coefficient is lower than -15 dB up to 20 GHz and lower than -5 dB up to 32 GHz.

To prevent EOM 1 from overvoltage, the limiter N9356C from Agilent technologies was chosen. It limits the signal to 25 dBm in a frequency range between 0.01GHz and 26.5GHz. The measurement results of an existing limiter at DESY and two ordered limiters are shown in Figure 6. The existing limiter # MY45450217 shows a reflection coefficient S_{11} lower than -15 dB up to 35 GHz and a transmission coefficient S_{21} better than -3 dB up to 32 GHz and -6 dB up to 36 GHz.

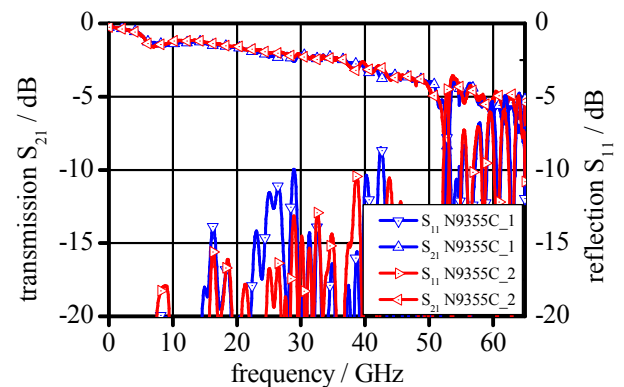

Figure 4: Transmission coefficient for the limiters Agilent N9355C.

Copyright © 2013 by JACoW — cc Creative Commons Attribution 3.0 (CC-BY-3.0)

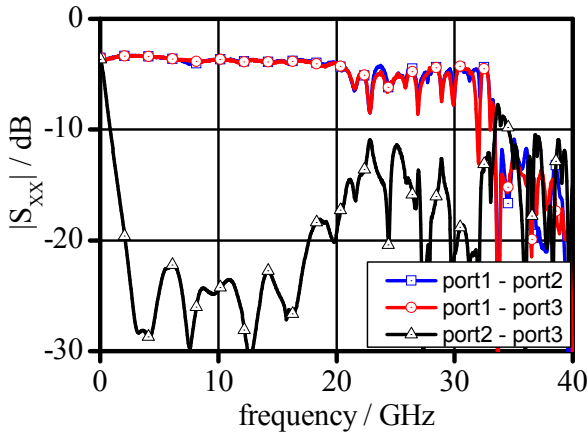

Figure 5: Transmission coefficient of the combiner ATM 213H.

Since the S-parameter measurements of the existing limiter exhibits excellent results up to 36 GHz the channel, since its power threshold of 25 dBm would allow the EOM to operate in the specified voltage range.

Therefore two additional limiters were ordered. Both new limiters unfortunately have a much lower cutoff frequency of 30 GHz (S_{11} -15 dB up to 30 GHz, S_{21} -3 dB @ 28 GHz and -6 dB @ 30 GHz). The cutoff frequency is with 30 GHz about 6 GHz lower than that for the existing device and therefore not useful for the 40 GHz path.

Cabling

For the cabling from the BAM pickups to the EOMs silicon dioxide (SiO₂) semi-rigid cables from Times Microwave were chosen. The distance between the BAM pickups and the BAM box is approximately two meters. The outer jacket of the SiO₂ cable consists of stainless steel, the outer and the inner conductor of copper and the dielectric is low density, high purity silicon dioxide (SiO₂). The temperature range of the cables with standard connectors is -200°C up to 200°C and the cable offers a excellent radiation resistance (not further specified).

Times Microwave offers different cable diameters from

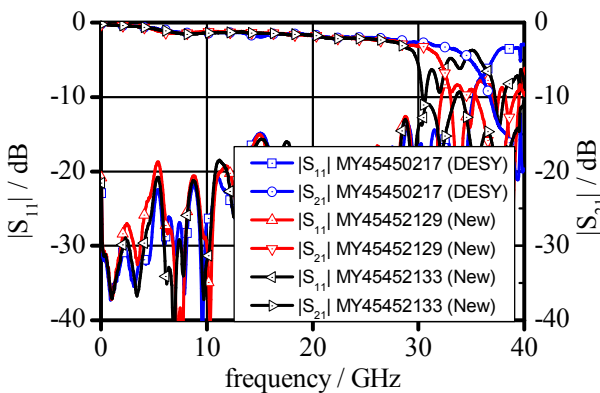

Figure 6: Transmission coefficient for Agilent N9356 limiters.

6.58 mm diameter for low frequency applications (f_{cutoff} =19 GHz) down to 2.286 mm for high frequency applications up to 65 GHz.

Two different cable types are suitable for the BAM cabling. The 38 GHz cable (3,58 mm diameter) has an attenuation of 2.75 dB/m @ 40 GHz whereas the 65 GHz cable (2,286 mm diameter) has about 50 % more attenuation (4.3dB/m).

For the BAM cabling the question raised, if a cutoff frequency of 38 GHz is sufficient, since the 3 dB roll off factor of the combiner is about 43 GHz. A conservative choice would be to use the thinner cable to prevent multimode propagation on the cable, but this would cost additional attenuation of the signal and thus a lower signal at the EOMs.

Using the software tool Microwave Office from AWR, simulations with different cable configurations were performed. The simulations include the simulation results of the BAM Pickups obtained from CST Particle Studio and the S-parameter measurements of the combiner and the limiters. The SiO₂ cables were simulated by a lossy coaxial cable model with the parameters given in Table 1.

Table 1: Dimensions of SiO₂ Cables [6]

	6.86 mm cable	3.58 mm cable	2.286 mm cable
Outer Diameter / mm	6.25	2.77	1.55
Inner diameter / mm	2.21	0.99	0.56
Attenuation / dB	1.115	2.75	5.57
f_{cutoff} / GHz	19	38	65

It is noticeable, that due to the extrapolation of S-Parameters and the exiting signal, the simulations with the Microwave office simulations sometimes show non-physically results. Nevertheless the simulation results clearly shows the trend and can therefore be used to choose the optimum setup.

To simulate the frequency response of the high charge and the low charge channel each of them was modeled with S-parameter blocks as shown in Figure 7.

All simulations are carried out with a cable length of 20 cm from the pickups to the combiner and 200 cm from the combiner to the EOM. Figure 8 shows the simulation results of the frequency response for different cable types.

It can be seen that for the red and green curve the cut-off frequency of the limiter limits the frequency response to 30 GHz. The usable bandwidth of the high charge channel is limited to 20 GHz. At 20 GHz the setup with 6.58 mm cables offers about 5.32 dB attenuation whereas the 3.58 mm cable offers 7.19 dB of attenuation. A crosscheck with a 3.58 mm cable for the connection

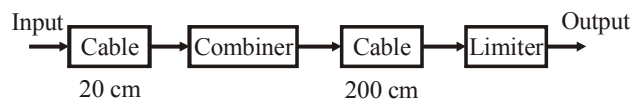

Figure 7: Block circuit diagram of the BAM RF front end.

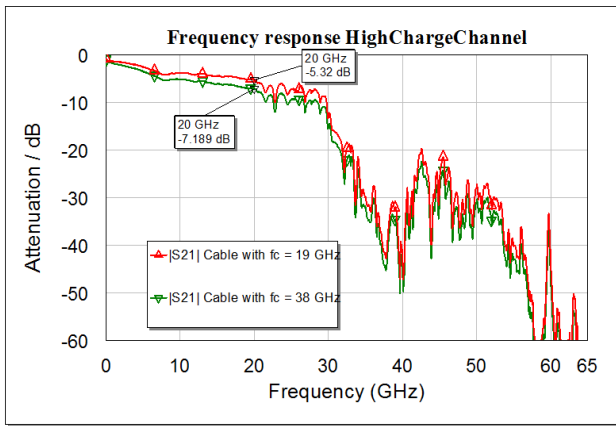

Figure 8: Simulation results for the low charge channel of the RF front end.

between pickup and combiner and a 6.86 mm cable from the combiner to the limiter shows nearly the same results as for the 6.58 mm cable setup, since the cable length between pickup and combiner is only 1/10 of the cable length from the combiner to the limiter.

When using the voltage signal obtained by simulations of the pickup with CST Particle Studio with a bunch charge of 20 pC the voltage response can be simulated. Figure 9 shows the voltage response of the single pickup and the high charge channel with 6.86 mm and 3.58 mm cables.

Using cables with higher losses as for the 3.58 mm cable causes additional attenuation and thus a reduction of the slope. Due to the fact, that within the high and low charge channel, two pickup signals are combined, the amplitude after the limiter can be higher than that for the single pickup. The slope of 394 mV/ps at a peak-to-peak voltage $V_{pp}=3.19$ V reduces to 207 mV/ps at $V_{pp}=3.28$ V and reduces further to 164 mV/ps at $V_{pp}=2.61$ V for the 3.58 mm cable. The results are summarized in Table 2.

The obtained spectrum is shown in Figure 10. Due to the lowpass characteristic of the 26 GHz limiter the usable frequency band is limited to 30 GHz. It is noticeable that the spectrum of the 3.58 mm cables is about 3 dB less than that for the 6.86 mm cables.

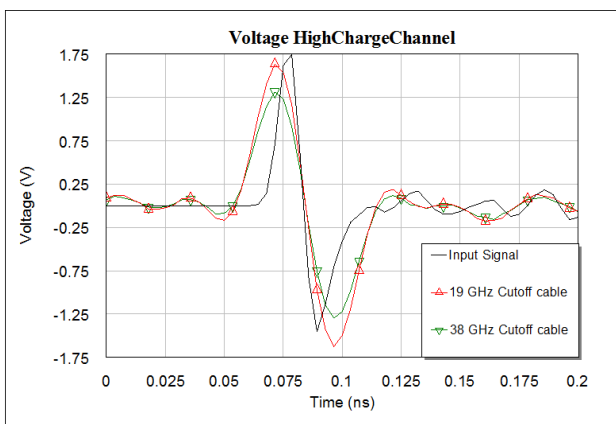

Figure 9: Voltage response of the high charge channel for different cable types for a bunch charge of 20pC.

ISBN 978-3-95450-119-9

Table 2: Slope and Voltage Reduction of the High Charge Channel

Parameter	single Pickup	6.86 mm cable	3.58 mm cable
Slope / mV/ps	394	207	164
V_{pp} / V	3.19	3.28	2.61
f_{cutoff} / GHz	40	19	38

The frequency response for the low charge channel is shown in Figure 10. A linear attenuation is obtained up to 43 GHz. Above 43 GHz the lowpass characteristic of the combiner dominates and limits the bandwidth. At 40 GHz the 3.58 mm cable channel offers about 12.8 dB attenuation and the 2.286 mm cable 16.2 dB. Thus, the thinner cable has 3.4 dB more losses and thus offers a significant reduction in the slope.

The voltage response of the low charge channel is shown in Figure 11. Due to good performances of the combiner and the limiter a slope of 264 mV/ps at $V_{pp}=3.22$ V is obtained for the 3.58 mm cables. Simulation results using the 2.286 mm cables show a reduced slope of only 146 mV/ps at $V_{pp} = 2.42$ V. The slope reduction is dominated by the high attenuation of the long cable with 2.86 mm diameter.

The simulation results for the low charge channel are summarized in Table 3.

Table 3: Slope and Voltage Reduction of the Low Charge Channel

Parameter	single Pickup	3.58 mm cable	2.286 mm cable
Slope / mV/ps	394	264	146
V_{pp} / V	3.19	3.22	2.42
f_{cutoff} / GHz	40	38	65

The spectra of all simulated channels are shown in Figure 12. One can see that the combiners and limiters are properly chosen for the application. Choosing the 3.58 mm cable to connect the pickups to the combiners, using the 6.85 mm cable for the connection from the combiner to the limiter for the High charge channel and

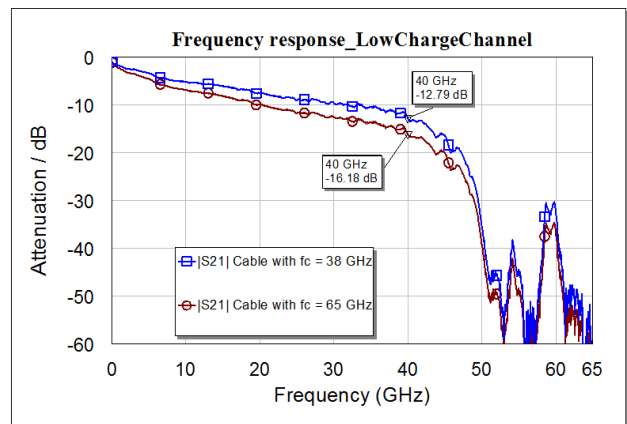

Figure 10: Simulated frequency response of the low charge channel for 3.58 mm cables and 2.286 mm cables.

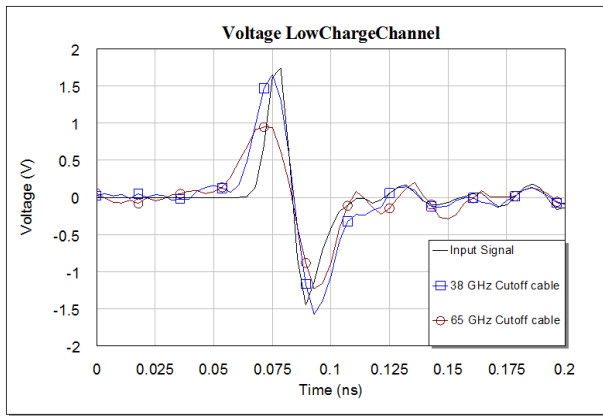

Figure 11: Simulated voltage response of the low charge channel for 3.58 mm cables and 2.286 mm cables for a bunch charge of 20pC.

the 3.58 mm cable for the low charge channel offers the best results.

CONCLUSION

In this paper, the proposed upgrade of the RF front end for the high bandwidth BAM is presented. It comprises a new low charge channel with increased bandwidth up to 40 GHz. All necessary components were ordered and characterized with S-parameters.

Using the software tool AWR Microwave Office the low and high charge signal path could be analyzed. The pickup signal, obtained from CST Particle studio for a bunch charge of 20 pC was used as input signals to the RF front end and the attenuation and distortion was simulated. For the cabling semi-rigid silicon dioxide cables with different cutoff frequencies were investigated in order to find the optimum cable type for the low and high charge channel.

Simulations of the low and high charge channel show that the 3.58 mm cable offers a sufficient voltage response and thus a sufficient slope for the low and high charge channel. Since the attenuation of the 2 meter long 6.85 mm cable offers about 1.8 dB more losses one can think about using this cable if V_{pp} is to low in the high charge channel. Simulations of the low charge channel clearly demonstrated that the thinner cable reduces the slope dramatically. It is worth using the 3.58 mm cable even if higher order modes can decrease the signal strength above 40 GHz.

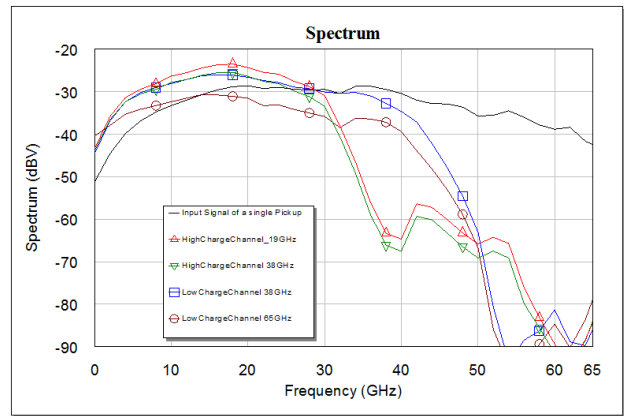

Figure 12: Simulated spectrum of the low and high charge channel.

ACKNOWLEDGMENT

The authors would like to thank the company CST for providing the CST MICROWAVE STUDIO software package. The authors would like to thank P. Gessler, S. Vilcins-Czvitkovits, M. Siemens of DESY, Hamburg and J. Rönsch-Schulenburg, J. Roßbach of the Institute for Experimental Physics at Hamburg University, Hamburg for the support.

REFERENCE

- [1] F. Löhl, et al., "Electron Bunch Timing with Femtosecond Precision in a Superconducting Free-Electron Laser", Physical Review Letters, Vol. 104, Issue 14, id. 144801, April 2010.
- [2] A. Angelovski et al., " Realization of a High Bandwidth Bunch Arrival time Monitor with Cone-shaped Pickup Electrodes for FLASH and XFEL ", IPAC 2011, San Sebastian, Spain, 4-9 September, 2011.
- [3] F. Loehl, "Optical synchronization of a free-electron laser with femtosecond precision", DESY-TESLA-FEL-2009-08 and DESY-Thesis-2009-031, 2009.
- [4] M.K. Bock, et al., "Recent Developments of the Bunch Arrival Time Monitor with Femtosecond Resolution at FLASH", IPAC 2010, Kyoto, Japan, 23-28 May 2010.
- [5] A. Angelovski, et al., "Pickup Design for High Resolution Bunch Arrival time Monitor for FLAH and XFEL", DIPAC 2011, Hamburg, Germany, 16-18 May 2011.
- [6] Times Microwave: www.timesmicrowave.com