

DESIGN OF A HIGH-PRECISION FAST WIRE SCANNER FOR THE SPS AT CERN

R. Veness, N. Chritin, B. Dehning, J. Emery, J. Herranz Alvarez, M. Koujili, S. Samuelsson, J.L. Sirvent, CERN, Geneva, Switzerland

Abstract

Studies are going on of a new wire scanner concept. All moving parts are inside the beam vacuum and it is specified for use in all the machines across the CERN accelerator complex. Key components have been developed and tested. Work is now focussing on the installation of a prototype for test in the Super Proton Synchrotron (SPS) accelerator.

This article presents the specification of the device and constraints on the design for integration in the different accelerators at CERN. The design issues of the mechanical components are discussed and optimisation work shown. Finally, the prototype design, integrating the several components into the vacuum tank is presented.

INTRODUCTION

Wire scanners are installed in the LHC and all circular machines in the injector chain as a means to measure the transverse beam profile and hence emittance. The motivation for the development of a new scanner design has been described in a previous article [1], along with the concept with the rotor of the motor and wire position measurement system inside the beam vacuum [see Figure 1]. Development of key components, in particular the motor and control system, are well advanced [2]. Work is now focussing on the integration of all the required components with the aim of producing a scanner capable of 20 ms⁻¹ scanning speed combined with 2 μm position precision.

A number of mechanical components require careful optimisation. These include the motor housing, shaft, bearings, fork and wire. In addition, the design concept includes an in-vacuum optical position encoder in order to reach the required precision. Development of these components is described in the following sections.

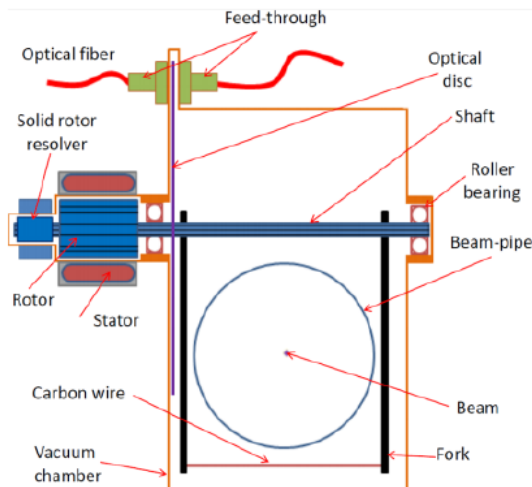

Figure 1: Fast Wire Scanner concept.

INTEGRATION CONSTRAINTS

Wire scanners are currently installed in the PS, Booster, SPS and LHC at CERN. It would greatly simplify operation and maintenance if the same basic design could be implemented for all of these machines. To this end, the main constraints in terms of machine physics, operation and environment have been analysed for each machine. These are summarised in Table 1.

Table 1: Summary of Integration Constraints from the CERN Accelerator Complex

Machine	Scan aperture (mm)	RF Screen	Bakeout	Space Constraint
PS Booster	146x70	N	N	Axial, Transverse
PS	146x70	N	N	Axial
SPS	152x83	Y	N	-
LHC	65x65	Y	Y	Transverse

The scan aperture is the horizontal and vertical space that must be cleared by the wire. RF screens are required in some machines to minimise impedance and RF heating effects. Integration of new scanners into existing machines must take into account machine geometries and equipment. Axial space constraints occur in machines with a tight lattice whereas transverse constraints are seen with parallel equipment on the beamline (eg, the cryogenic distribution line in the LHC). It can be seen from table 1 that each of the machines brings constraints to the design. A solution has been adopted where the main components can be integrated into designs for the PS, SPS and LHC. Each machine will require a different fork geometry and a different flange interface, but other main components and principles will be common. The layout of the Booster with 4 rings in very close proximity mean that it has not yet been possible to integrate the design into this machine.

Combining these constraints leads to a design with aperture range up to 152 by 152, with the option to include RF screen and to be bakeable to 200°C in order to activate a low emission yield getter coating used in the LHC vacuum system.

DESIGN OF COMPONENTS

Motor Housing

The motor housing has the function of separating the rotor in-vacuum and stator on the atmospheric side of the

Copyright © 2013 by JACoW — cc Creative Commons Attribution 3.0 (CC-BY-3.0)

electric motor. The housing needs to be thin to fit in the relatively small air gap (approximately 0.8 mm) between the rotor and stator. The required wall thickness of the housing has been determined using finite element method (FEM) analysis. The analysis shows that elastic instability is the critical failure mode. The stability of the structure increases strongly with wall thickness. The dependence of stability on the length of the structure is weaker, where a shorter structure increases the stability. Furthermore, a thicker housing (within the limits of this problem) is easier to manufacture. When all the above mentioned considerations are put together, the optimum wall thickness of the motor housing is determined to be 0.4 mm.

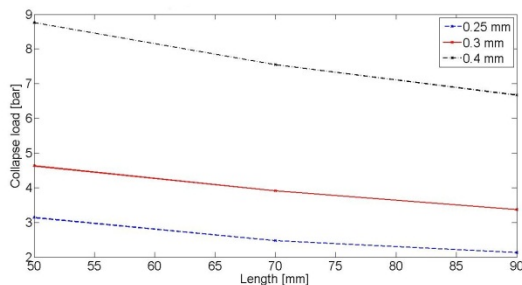

Figure 2: Graph of motor housing collapse load for different lengths and wall thicknesses.

Shaft and Bearings

One principal of this design is to support forks and position measurement system on one rigid structure to maximise precision. The shaft forms the core of the mechanical structure. It is driven by the motor and supports the rotor, forks and optical disc. The main constraint on the shaft is its deformation in torsion. The torsional deformation appears due to the acceleration of the shaft and the inertias of the components mounted on the shaft. This deformation must be kept small to ensure accuracy of the measurements. Although the shaft is not accelerating when the wire passes through the beam, the shaft will vibrate with a maximum amplitude corresponding to the torsional deformation due to the acceleration. The shaft needs to be hollow to be able to pass cables through it. Analysis of the shaft, using analytical calculations and FEM simulations, show that using a larger outer diameter has a strong effect on the stiffness. It is also shown that the stress in the shaft is low and the inertia of the shaft is of little importance compared to the inertias of the components mounted on the shaft. This means that the strength of the material is not critical and that a stiff, relatively heavy stainless steel is a better material choice compared to lighter, more flexible alternatives such as aluminium or titanium. The analysis also shows that it is the optical disc and the disc holder which give the largest contribution to the shaft twist. This is because they are mounted on the shaft end opposite to the motor. Therefore effort should be put into minimising the mass of these components. Figure 3 shows the offset of the wire position relative to the

encoder which the shaft vibrations give rise to. The calculations show that an outer diameter of 35 mm is needed to keep the deformation below the tolerated limit of 5 μm .

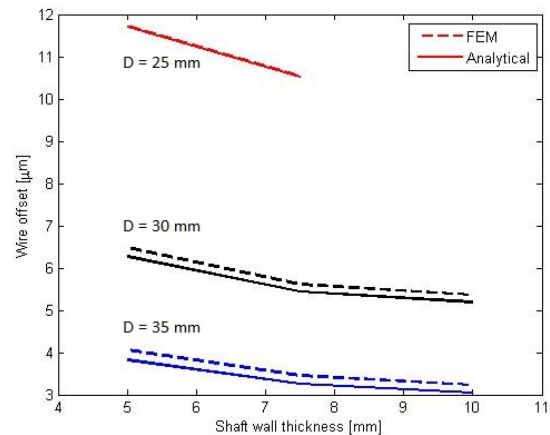

Figure 3: Graph of relative offset of wire vs. encoder for different shaft diameters and thicknesses.

The bearings need to assure high precision in terms of radial runout and the materials used must be UHV compatible and radiation and bake out resistant. This means that traditional lubricants such as oil and grease cannot be used [3]. Instead one must rely on running the bearings without any lubricant or possibly using solid lubricants (such as molybdenum disulphide or tungsten disulphide coatings). It is also recommendable to use different materials for the races and the rolling elements in the bearing, to avoid cold welding. One available alternative for this is hybrid bearings which use steel races and ceramic rolling elements.

Optical Disc and Support

The principle selected for the high precision determination of the beam size is an optical system based on a glass disc with a photo-lithographed μm pattern made of high reflectivity chrome, placed inside the vacuum chamber and fixed on the scanner shaft. This incremental angle encoder uses single-mode optical fibre and UHV fibre optic feedthrough (9/125 μm) to drive 1310 nm laser light on a 1:1 lens system in-vacuum that focuses the light on the disc surface with a 10 μm light spot size. Using the reflectivity of the chrome pattern, the reflected light is coupled back into the same fibre, and through an optical circulator directed to the photodiode. The laser diode, circulator, photodiode and subsequent electronics will be located in the surface building and only one optical fibre will go down to the accelerator tunnel (250 m). The performance of this single fibre angular position sensor has been tested and validated on the bench shown in Fig 4.

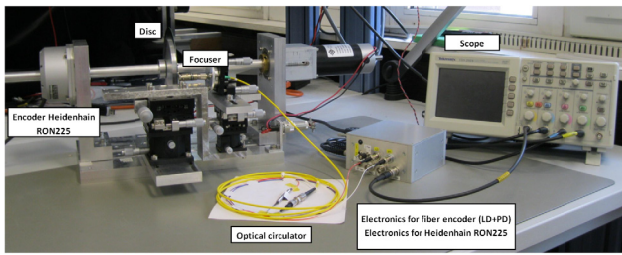

Figure 4: Test bench for the optical position sensor.

This fibre encoder provides a resolution of 157 μ Rad with a track of 10 μ m slits, and two position references using only one channel. An accuracy of $\pm 25 \mu$ Rad is reached by angular calibration with a commercial encoder Heidenhain RON225 (Fig. 5). With this calibration, eccentricity errors, and partly grating errors can be minimized.

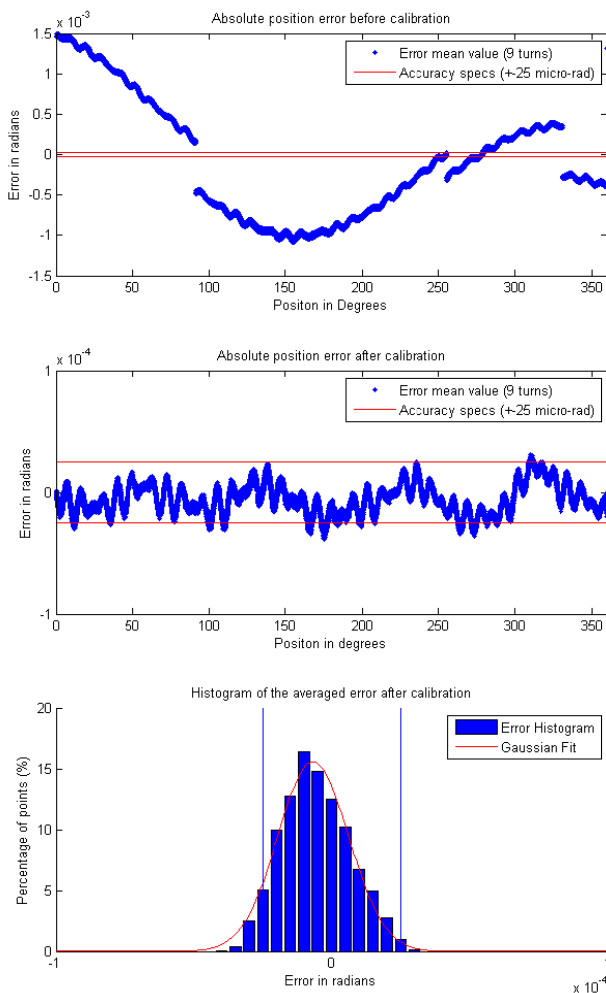

Figure 5: Error before calibration (top), calibration applied (center) and error histogram (bottom). Calibration made with Heidenhain RON225 angular position sensor.

The final system is UHV compatible with EMI immunity, works with temperatures up to 200°C, and it is radiation tolerant due the special fibre used. Studies are

on-going to verify the use of a 5 μ m track to reach better mechanical resolutions (around 70 μ Rad), and the incorporation of other calibration methods on the scanner working axis to perform a more reliable calibration procedure.

Magnetic Restraint System

The design will integrate a magnetic restraint in order to prevent unplanned movements of the fork during transportation or installation and also during operation in case of power or control system failure.

Uncontrolled movement of the wire within the beam aperture could cause the melting of the wire and quenching of superconducting magnets (in the case of the LHC). This effect is enhanced as the wire speed due to its own unbalanced weight would be much slower than the nominal speed required for safe operation of the scanner.

The conceptual design of the restraint system consists of a magnetic circuit in two parts: One part outside of the vacuum has a permanent magnet and electrical coil; the other part inside the vacuum consists of a ferromagnetic piece fixed to the shaft. This has two poles that, when aligned with the external magnetic circuit, define an equilibrium position corresponding to the ‘parked’ fork positions. When the electric coil is energized it cancels the field of the permanent magnet allowing the shaft to rotate freely. This concept can be seen in Figure 6.

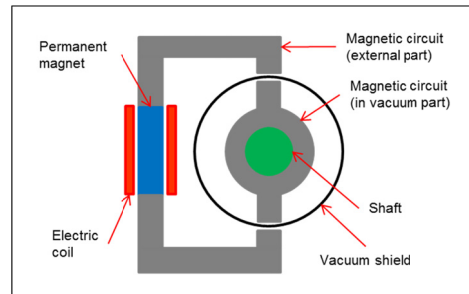

Figure 6: Conceptual design for the magnetic restraint system.

Forks

The two forks which support the wire need to be carefully optimised. They need to be stiff enough to maintain the wire under tension and prevent excessive deformation and vibration during wire acceleration. However the forks are also a major component of the inertial load on the shaft and motor, so the mass and mass distribution need to be optimised. From the manufacturing viewpoint, there will be different designs for each machine due to the different apertures, so quantities will be small.

Considering all of these factors, it is logical to consider making these components using metal additive manufacturing [4] (also referred to as 3D printing). This method will allow complex geometries to be optimised using FEM, and produced directly in small quantities from 3D CAD models allowing for forms that cannot be produced with conventional machining.

Studies of the wire are on-going and will be presented separately.

STATUS AND NEXT STEPS

All major components have been integrated into a 3D model with an envelope which would allow installation into the PS, SPS or LHC. Figure 7 shows a section through this model. The scanner is assembled as one self-contained 'cartridge' that will be inserted into the accelerator vacuum chamber. This will protect the wire from damage during insertion – a common problem with existing designs. A prototype will be constructed and tested in the coming months to verify the operation of the scanner assembly and performance. It is then planned to produce a first production model for test in the SPS accelerator. This will be installed in the forthcoming 'Long Shutdown 1' of all CERN accelerators in 2013-14. The plan is then to produce a series of scanners for installation in the second Long Shutdown scheduled for 2018-19.

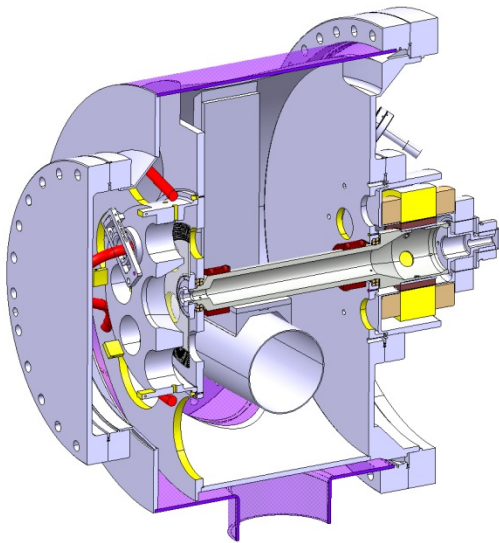

Figure 7: 3-D model section through the scanner.

REFERENCES

- [1] M.Koujili et al. 'Fast and High Accuracy Wire Scanner' DIPAC'09 Conference – 25-27 May 2009 /Basel-CH
- [2] B.Dehting et al. 'Vacuum Actuator and Controller Design for a Fast Wire Scanner' Proceedings of BIW2012, Newport News, Virginia, USA
- [3] D. Ramos 'Bibliographic search on bearing technology for ultra-high vacuum applications' Internal communication (2008).
- [4] L.E. Murr et al. 'Metal Fabrication by Additive Manufacturing Using Laser and Electron Beam Melting Technologies' J. Mater. Sci. Technol., 2012, 28(1), 1-14.