

FLYING WIRE BEAM PROFILE MONITORS AT THE J-PARC MR

S. Igarashi[#], D. Arakawa, Y. Hashimoto, M. Tejima, T. Toyama, KEK, Ibaraki, Japan
 K. Hanamura, MELCO SC, Ibaraki, Japan

Abstract

Transverse beam profiles have been measured using flying wire monitors at the main ring of the Japan Proton Accelerator Research Complex. We use carbon fibers of 7 μm in diameter and the scan speed of 10 m/s. The wire is attached with an aluminum flame of 140 mm of the rotation radius and rotated with a DC servomotor. A potentiometer is attached to the wire flame and the angle readout is used for the feedback of the servomotor and the wire position measurement. The secondary particles from the beam-wire scattering are measured with a scintillation counter. Beam profiles are reconstructed by making the scatter plot of the scintillator signal and wire position. We have successfully measured both horizontal and vertical beam profiles of up to 1.2×10^{13} protons per bunch. The monitors have been proven to be useful for the beam commissioning.

INTRODUCTION

The main ring (MR) of the Japan Proton Accelerator Research Complex (J-PARC) is a high intensity proton accelerator and delivers the protons for the nuclear and elementary particle physics, such as the neutrino oscillation experiment (T2K). The injection energy is 3 GeV and the extraction energy is 30 GeV. For the user run we have achieved the beam power of 200 kW with 8 bunches of 1.3×10^{13} protons per bunch (ppb). Two bunches of protons are injected in MR from the rapid cycling synchrotron (RCS) through the beam transport line (3-50BT). Two bunches are injected four times in one cycle to fill 8 out of 9 rf buckets in 120 ms. The acceleration starts after the fourth injection.

The beam loss minimization and localization at the collimator are necessary to minimize residual radiation activities in MR and required for the maintenance of the accelerator components. The typical beam loss is 1% during the injection period and 0.7% at the beginning of the acceleration. It is important to understand the beam loss mechanism for further beam power increase.

The transverse beam profile is one of important beam parameters to measure for understanding of the beam loss mechanism. We have installed ion profile monitors (IPM) [1] and flying wire in MR. IPM uses phenomena that the proton beam ionizes the residual gas. Multi-ribbon profile monitors [2] have been installed at five places in 3-50BT and one in MR. They are being used to measure the injection beam profiles.

FLYING WIRE MONITOR

A flying wire monitor uses a carbon fiber of 7 μm in diameter as a target. It is to be scanned across the beam

[#]susumu.igarashi@kek.jp

with the maximum speed of 10 m/s. The wire is attached with an aluminum flame of 140 mm of the rotation radius and rotated with a DC servomotor. A potentiometer is attached to the wire flame and the angle readout is used for the feedback of the servomotor and the wire position measurement. The secondary particles from the beam-wire scattering are detected with a scintillator (Fig.1). The beam profile is then reconstructed from the scintillator response and the wire position measurement. If the wire scanning disturbs the beam, the profile measurement is not precise. The minimum target material and fast wire scanning are necessary. Flying wire monitors have been used in several proton accelerators. It was also developed in KEK-PS [3] and modified for J-PARC MR [4].

The wire flame is rotated from -150° , which is the standby position, to $+150^\circ$ and comes back to the standby position. The movement is done in 0.2 s. The wire scanning takes about 5 ms for a typical size of the beam. The scintillator signals and the potentiometer output signals for the wire position are digitized with a digitizer RTD720A with a 20 ns sampling for a 20 ms time range. The 1 M sample data are averaged over 10 k sample to make arrays of 100. The data of the potentiometer signal is calculated to make wire position data. Scattered plots are made for the scintillator data as a function of the wire position to make beam profiles.

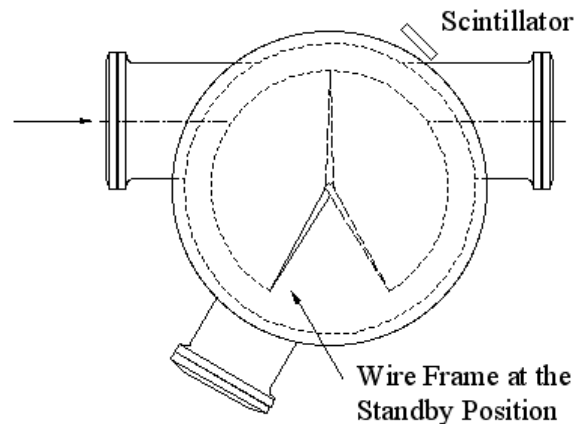

Figure 1: The flying wire monitor.

Both horizontal and vertical flying wire monitors were installed in the straight section of the beam injection and collimation systems in 2008 (Fig.2). Because they were originally at the downstream of the collimator, the beam background affected the profile measurement. They were moved to the upstream of the beam injection and collimation systems in 2010 to avoid the beam background. The background was then suppressed and the profile measurement of the high intensity beam became

possible. The betatron amplitude function β_x is 15.4 m at the position of the horizontal flying wire and β_y is 18.5 m at the position of the vertical flying wire. The dispersion functions η_x and η_y are zero for both monitors.

After the earthquake in 2011, a driver circuit for the DC servomotor turned out to be damaged. The circuit was replaced for repair. Otherwise the operation of the monitor has been stable. Wire breakage has never occurred in four years since the first installation.



Figure 2: Installation of the horizontal flying wire monitor.

BEAM BACKGROUND

Beam profiles were measured during the injection period of 120 ms for the intensity of 0.95×10^{13} ppb. Two bunches were injected at the injection timing, k_1 . The measurements were performed with the trigger timing of k_1 , k_1+20 ms and k_1+120 ms. The data were acquired in the different shots but in the same condition. Figure 3 shows the beam profiles at the injection timing k_1 in black circles. It is well fitted with the Gaussian function as shown in the solid line. Profiles at 20 ms after the injection and at 120 ms after the injection are shown in red circles and blue circles respectively. The beam background was observed at the level of about 2 % with respect to the peak of the profile. If the profile is in the Gaussian function, the profile signal of 2.8σ should be at the background level. A part of 99.5 % is then observable and the rest of 0.5 % is not observable by the background. If the beam profile is not in the Gaussian function but has more tail distribution, the ratio of the unobservable part increases.

For the high intensity beam operation we would like to maintain small beam losses, typically about 1 % or less. The beam halo of much less than 1 % level should then be measured in order to understand the beam loss mechanism. More detail studies of the beam halo and loss mechanism would be possible if we could improve the signal to noise ratio. Ideas to improve the signal to noise ratio such as a use of scintillator telescope, an

optimization of wire thickness and wire movement should be explored.

Flying Wire Horizontal Profile $0.95e13$ ppb

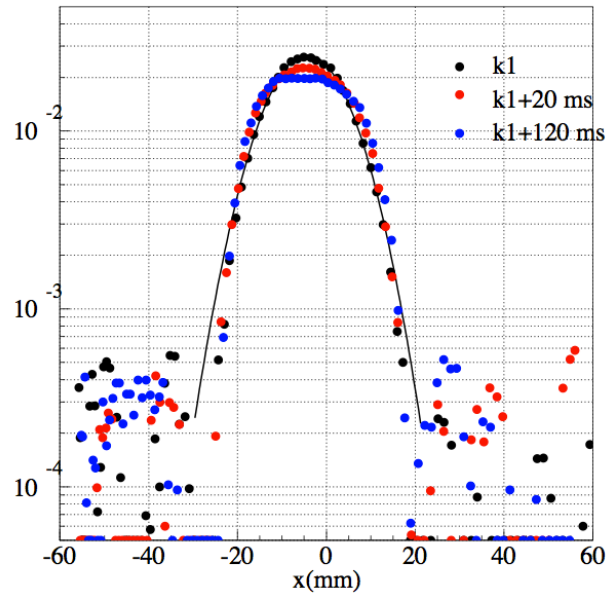

Figure 3: Horizontal beam profiles of the two-bunch beam for the intensity of 0.95×10^{13} ppb. The beam profile at the injection timing k_1 is shown in black circles and the fitted Gaussian function is shown in the solid line. Profiles at 20 ms after the injection and at 120 ms after the injection are shown in red circles and blue circles respectively.

PROFILE CHANGE DURING THE INJECTION PERIOD

Both horizontal and vertical profiles have been acquired for 1.19×10^{13} ppb. Trigger timing was set to k_1 , k_1+20 ms and k_1+120 ms to observe the profiles during the injection period.

Figure 4 shows the horizontal profiles during the injection period. The profile at the k_1 timing was observed to be in a Gaussian shape. The 2σ emittance was 20.1π mmmrad. A small change of the profile has been observed at the k_1+20 ms timing from the Gaussian shape. The profile change was clear at the k_1+120 ms timing. The profile was in a parabola shape. The 100% emittance was 36π mmmrad.

The vertical profiles in the same condition have been observed to have the same change as shown in figure 5. They were in a Gaussian shape at the k_1 timing and in a parabola shape at the k_1+120 ms. The 2σ emittance was 24.7π mmmrad and at the k_1 timing. The 100% emittance was 26π mmmrad at the k_1+120 ms.

To understand the mechanism of the profile change, we have performed multi-particle tracking simulations with the space charge effect. The study revealed that the space charge tune shift and the linear and 3rd order coupling resonances are the causes of the profile change [5].

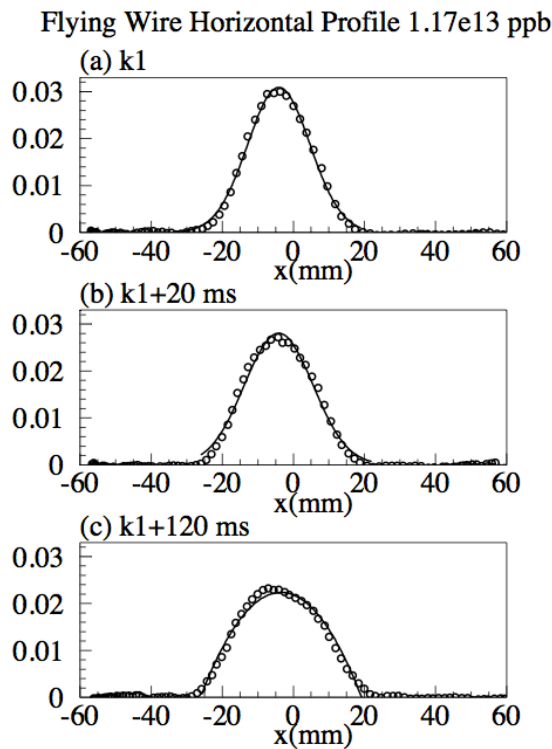

Figure 4: Horizontal beam profiles at the trigger of k1 (a), k1+20 ms (b), k1+120ms (c).

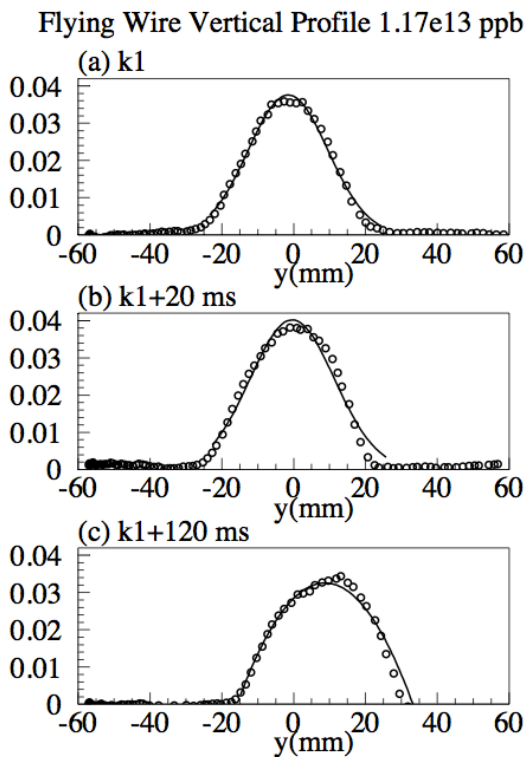

Figure 5: Vertical beam profiles at the trigger of k1 (a), k1+20 ms (b), k1+120ms (c).

BEAM PROFILES IMMEDIATELY AFTER THE INJECTION

The profile data have been acquired with changing the trigger by 1 ms step with respect to k1 (the injection timing of the first bunch), because we would like to observe the profiles immediately after the injection. Figure 6 shows the horizontal beam profiles for the beam intensity of 0.6×10^{13} ppb. In order to reconstruct the beam profile immediately after the injection, we should take the profile data with smaller trigger steps such as 0.2 ms and rearrange the data as a function of the timing with respect to the injection timing. The analysis has not been done for this sequence of profiles. We have, however, observed a change at the top of the profile in 10 ms after the injection. The profile peak was observed to be sharper immediately after the injection.

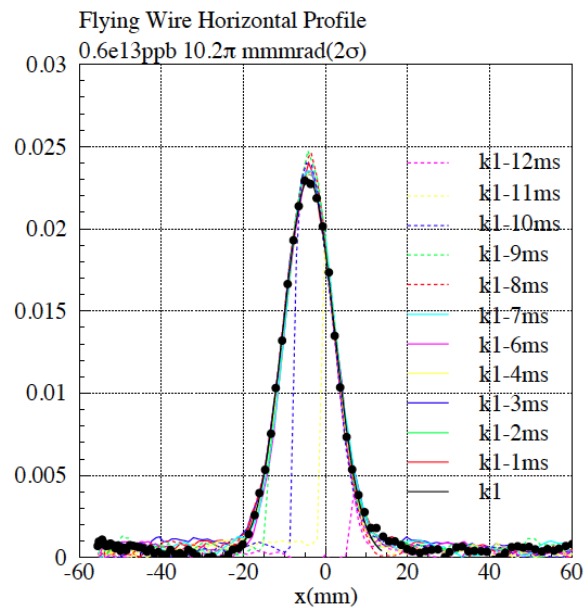

Figure 6: Horizontal beam profiles at the injection for the beam intensity of 0.6×10^{13} ppb.

SUMMARY

Flying wire monitors have been used for the horizontal and vertical beam profiles in the J-PARC MR. The operation has been stable and the profile data have been acquired up to the beam intensity of 1.2×10^{13} ppb. Wire breakage has never occurred in four years since the installation. We have successfully reconstructed beam profiles such as the profile immediately after the injection and during the injection period. The monitors have been proven to be useful for the beam commissioning.

REFERENCES

- [1] K. Satou et al., “IPM Systems for J-PARC RCS and MR”, Proceedings of HB2010, Morschach, Switzerland, Sep. 27 ~ Oct. 1 2010.
- [2] Y. Hashimoto et al., “Multi-Ribbon Profile Monitor Using Carbon Graphite Foil for J-PARC”, Proceedings of HB2010, Morschach, Switzerland, Sep. 27 ~ Oct. 1 2010.
- [3] S. Igarashi et al., “Flying Wire Beam Profile Monitors at the KEK PS Main Ring”, Nucl. Instrum. Meth. A482;32-41, 2002.
- [4] S. Igarashi et al., “Flying Wire Beam Profile Monitor at the J-PARC MR”, Proceedings of the 5th Annual Meeting of Particle Accelerator Society of Japan, Higashihiroshima, Japan, Aug. 6~8 2008.
- [5] S. Igarashi et al. “Beam Profile Measurement using Flying Wire Monitors at the J-PARC Main Ring”, Proceedings of IPAC2011, San Sebastian, Spain, Sep. 4~9 2010.