

DESIGN OF THE BEAM PROFILE MONITORS FOR THE SXFEL FACILITY

L.Y.Yu, J.Chen, W.M.Zhou, K.R.Ye, Y.B.Leng
SINAP, Jiading, Shanghai 201800, P.R.China

Abstract

The Shanghai X-ray Free Electron Laser Facility will begin construction at next year. The linac electron beam energy is 0.84 GeV. Over 50 beam profile monitors with OTR and Yag screen will be installed along the linac and undulators. The profile monitor system design is a challenging task, since the system has to measure transverse electron beam sizes from millimeter down to 40 μ m scale with a 20 μ m resolution and 50 μ m repeat positioning accuracy. This paper describes the design of the mechanical detector, the integrated step-servo motor controlling system, the beam imaging system, as well as the software system.

INTRODUCTION

SXFEL proposal was approved in February 2011 by China government, the construction is expected to start at the SSRF campus in early 2012. This test facility, based on an 840MeV electron linac, aims at generating 8.8nm FEL radiation with two-stage cascaded HGHG scheme[1]. Figure 1 shows the layout of the SXFEL linac.

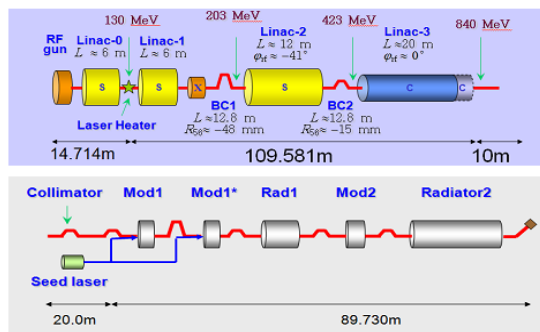

Figure 1: Layout of the SXFEL accelerator & undulator.

SXFEL injector have 3 beam diagnostic stations, require 6 beam profile monitors designed by Tsinghua University, linac part requires about 31 beam profile monitors or so, undulator part require 21 beam profile monitors.

Table 1 list the physical specification of the beam profile monitors[2].

We are going to use Yag/OTR screens and wire canners as the beam profile monitors originally. Considering the cost, reliability and we have not any experiences on wire scanners, so we decide to improve the design of Yag/OTR profile monitor to satisfy the specification. In addition the system has to be robust, remote controlled and easy to maintain, we adopt a new type integrated step servo

motor to redesign the mechanical detector and select a high resolution CCD, the whole profile system is more compact.

Table 1: Specification of the beam profile monitors

Parameter	Linac	Undulator
Quantity	31	21
Monitor length	210mm	150mm
Repeat positioning accuracy	50 μ m	
Resolution	20 μ m	
Charge range	0.02~1nC	
RMS beam length	0.015~4 ps	
Measuring range	15*15/5*5 mm ²	

MECHANICAL DETECTOR

The beam profile monitor will be a main diagnostic tool during the commissioning of SXFEL experiments. It has three position screens for test. One is the calibration screen, The beam profile monitor is not only used to measure the electron beam transverse shape and size, but also to synchronize the seeding laser and electron beam on spatial domain and temporal domain respectively. So all beam profile monitor is designed as shown as Figure2 with four stages pneumatics screen monitor. One screen which material is YAG:Ce crystal plate is used at the initial commissioning and at low beam charge situation, another screen which material is made from 100nm aluminium deposited on a polished silicon wafer[3], generating optical transition radiation(OTR) when Electron hits on it, is used to measure beam energy spread and beam emittance respectively, because the OTR represents a linear radiation source while YAG screen has the saturation problem. The last screen is calibration screen where holes array radius is 1mm and spacing is 5mm. It is used for calibrate the optical relay and CCD image acquisition system. The light of beam can be extracted from both viewport, at the undulator location, the energy of seeding laser is very huge to damage the CCD camera, so the beam image can be obtained from backside viewport. The camera is located below beam pipe 1.1 meter through planar - mirror optical relay to reduce the radiation damage. The viewport flange can be replaced conveniently with crystal viewport flange

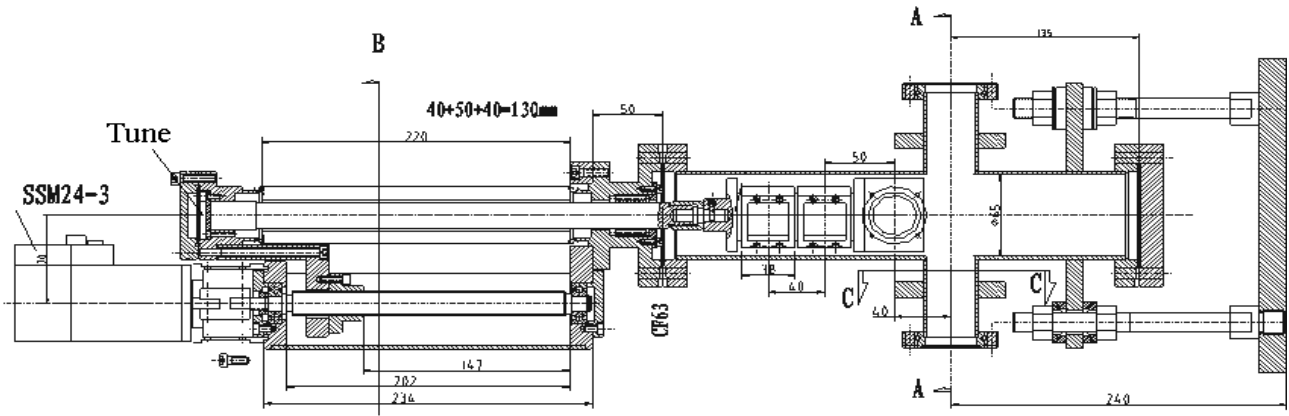

Figure 2: Design of the mechanical detector.

where the ultraviolet light is need to extract from the screen[3].

To ensure the angle between screen and beam line is 45degrees, we add a new design named tune on the mechanical detector, it can be fine rotated the axis of the screen. Combined with the optical setup, we can calibrate the 45degree accurately. Figure 3 is the finished prototype mechanical detector.

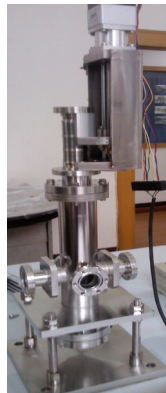

Figure 3: Prototype mechanical detector.

MOVER CONTROLLING SYSTEM

We select a new type motor for the design of beam profile monitor SXFEL, The type is SSM24Q-3RG produced by China. Figure 4 shows the overview of the integrated step servo motor.

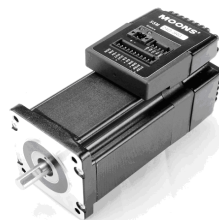

Figure4: Integrated step-servo motor.

High stiffness due to the nature of the stepper motor combined with the highly responsive servo control, space vector current control with 5000 line high resolution encoder, gives smooth and quiet operation, especially at low speeds. The SSM24Q motor integrates the motor, driver, controller, encoder and IO, so the mover controlling system is very concise, the motor can start to work just providing DC24V&DC48V and RS485 bus, DC24V is used to supply the IO, DC48V is used to supply the motor, serial commands directly to the driver to communicate with the motor by RS485 serial bus. The output torque is 2.4N.m, it can easily pull out the screen quickly off the beam line without the help of deceleration mechanism. To avoid screen stopping the beam line, the mover works smoothly and stably with very low noise. Figure 5 shows the block diagram of SSM24Q[5].

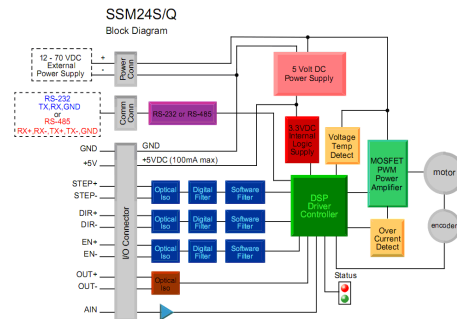

Figure 5: Block diagram of SSM24Q.

We can use the In connector of the motor as the screen state display function, use the Out connector of the motor as the illuminate function for the optical part. Use the encoder of the motor to position the screens without extra using grating ruler which is used at the beam profile monitor of SDUV-FEL. All the function realization implement with serial commands.

This motor has a high positioning accuracy, encoder resolution is 20000 counts/rev, the positioning error is only±0.018°, so the beam profile monitor can satisfy the physical requirement: repeat positioning accuracy<50 μm.

OPTICAL SET-UP

The optical system used to image the YaG/OTR light to the CCD camera is almost the same with the design of SDUV-FEL, except the CCD type, it consists of a mirror deflecting the OTR light downwards, one focus lens, and a CCD camera, providing nominal magnification is 1. The components are mounted on two rails on a stainless steel plate. The plate will be fixed to the support structure of the machine. The optical system is protected against the stray light, and the CCD camera is shielded with lead to reduce radiation damage. The camera is a digital CCD camera (Basler scA1000-30) with Ethernet interface. The sensor size of the camera is 1034 x 779 pixels with a pixel dimension of 4.65 μm x 4.65 μm .

The initial adjustment of the optical set-up will be done on an optical table. The optical axis is defined with a help of a He-Ne laser. The correct position of the lens is searched by manually measuring the contrast on a calibration target. When the correct position of the lens and the camera is ok, their position is fixed. On the beam line, the distance of the whole system from the screen is adjusted with the help of the marks on the calibration screen. The same marks are used to calibrate the magnification.

The GigE Vision camera is adopted based on following two main advantages: First, digital signals can be transmitted much more stably than analog signals over long distance. Second, The GigE CCD camera gain parameter can be adjusted remotely according to the beam intensity during commissioning[4]. Basler scA1000-30 CCD cameras were chosen as the major devices in image acquisition subsystem. With a 1:1 lens, the spatial resolution could be 10 microns. The range of gray scale could be 0 to 65535 because the camera has a 16 bits ADC. External trigger mode is important for the system, because the action of capturing the beam images must synchronize with the timing signal of the entire system.

SOFTWARE

The beam profile monitors control system is simple and flexible using two filed buses: The industrial Ethernet bus for communication between control room and cameras; The 485 serial bus for communication between control room and the integrated step-servo motor.

Use the MOXA serial servers can easily convert the RS485 signals to Ethernet signals. The beam profile monitors control system software is based on EPICS, every beam profile monitor control system can be designed as a standard software IOC.

STATUS AND OUTLOOK

The prototype mechanical detector of the beam profile is ready and the mover control software is ok, the screen moving control is very smooth and stable. The prototype of the optical set-up will be installed in lab on November this year, and the first table test will be done soon. The test of the digital camera system continues and the

decision of the final solution for the connection scheme will be made within a few months. We will do some simulation and test of the screen materials, to select more suitable one. The whole YaG/OTR beam profile monitor system is expected to be finished 5 month later.

ACKNOWLEDGMENT

The authors would like to thank colleagues at FEL Group in SINAP for the valuable discussions. Special thanks are due to H.B.Pan for many mechanical designs support.

REFERENCES

- [1] Z. T. Zhao, S.Y. Chen, L.H. Yu, C.X. Tang , L.X. Yin, D. Wang, Q.Gu, "Shanghai Soft X-Ray Free Electron Laser Test Facility", THPC053 Proceedings of IPAC2011, San Sebastián, Spain.
- [2] Z. T. Zhao, L.H. Yu, C.X. Tang , L.X. Yin, D. Wang, Q.Gu et al., "CDR of SXFEL", 2011.
- [3] Y.Z.Chen, Y.C Xu, L.F.Han, W.M.Zhou, L.Y.Yu et al., "Beam Diagnostics at SDUV-FEL", FROA3, Proceedings of FEL2010, Malmö, Sweden .
- [4] Y. C. Xu, Y. Z. Chen, L. F. Han, et al., "A New Beam Profile Diagnostic System Based on the Industrial Ethernet", MOPE033, Proceedings of IPAC'10, Kyoto, Japan.
- [5] "Specification of the SSM24Q", P2, 2011.