

# PROTOTYPE LASER EMITTANCE SCANNER FOR SPALLATION NEUTRON SOURCE (SNS) ACCELERATOR\*

J. Pogge, Igor Nesterenko, Alexander Menshov, Dong-O Jeon, SNS Oak Ridge National Laboratory, Oak Ridge, Tennessee 37831, USA

## ABSTRACT

Taking advantage of recent successes with the Laser Wire, a new prototype is being built to use the laser wire as both a profile monitor and a slit for an emittance measuring device. This improved system takes advantage of the steering dipole magnet prior to ring injection of SNS such that only the recently stripped  $H_0$  protons continue forward to the emittance device. In this way we hope to make an emittance device that is both parasitic to neutron production and is capable of accurate measurements during full-power applications.

## INTRODUCTION

As spallation neutron sources have demonstrated increasing power, it has become necessary to accurately measure the transverse phase-space distribution (emittance) of the  $H_0$  beam prior to introduction into the storage ring. The high power of the proton beam and the necessity for non-destructive measurements make the use of a laser profile monitor as the emittance scanner slit especially attractive by replacing the more common and well known slit-grid (slit-harp) [1] mechanism used in lower power emittance measurements. The basic principal has been demonstrated in experiments with energies higher than 600 MeV [2,3,4]. This device will attempt to achieve results with a proton beam with energies as high as 1.4 GeV. The system is divided into two sections: the Laser Profile Monitor (LPM) and the Emittance Collection Device (ECD). The LPM is similar in capability to that of previous laser wire devices [5,6]. Specifications for this LPM are found in the following table.

Table 1. Laser Profile Monitor Specifications

X – Y Range	+/- 32 mm	100nm resolution
Laser /H- intersection	20 – 40 um	3% neutralization
Laser Energy	50 mJ	10 - 20 nS pulse
H- Beam	1.4 GeV	60 Hz

## ENGINEERING CHALLENGES

The SNS Laser Emittance Scanner design takes advantage of the first dipole steering magnet in the ring

injection section to separate the  $H^-$  representing 97% of the produced beam, from the recently generated  $H_0$ , 3% stripped by the LPM device. The primary LPM location also contains vacuum pumps, gate valves, and a key access point for moving equipment in and out of the tunnel in the HEBT section of the SNS accelerator. The design will be significantly more compact than its predecessor Laser Wire design used in 14 locations throughout the superconducting LINAC at SNS. This is primarily to allow for quick installation and removal of the LPM. The relatively low power of the separated  $H_0$  allows the designers to evaluate either a scintillator camera device and a more traditional scanning harp assembly for the actual emittance collection system. This collection device will be located downstream in the LINAC dump area of the SNS accelerator approximately 11 meters from the LPM.

## IMPROVED OPTICAL DESIGN

The prototype LPM under construction at SNS (Fig. 1) uses an improved optical system to increase repeatability and accuracy of the scanning optics with a decrease in overall size.

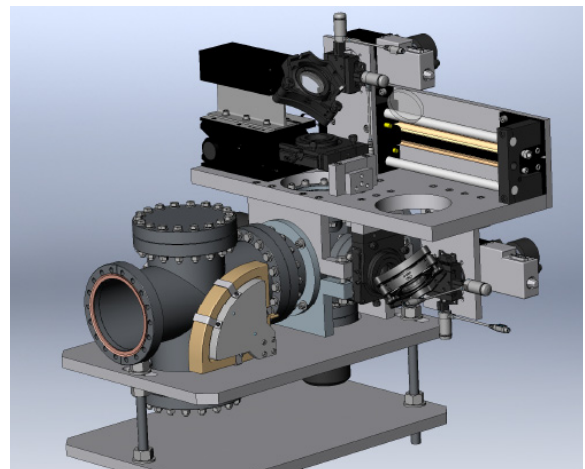

Figure 1: Improved LPM at SNS.

The new LPM also incorporates an embedded 50 mJ 1064 nm Nd:Yag pulsed laser, dramatically reducing the complexities of laser delivery to the optical scanning system. Stepper driven linear stages have been replaced with fixed angular scanning mirrors that have been precisely aligned and locked down prior to

installation. A focusing singlet is placed at a distance from the steering mirror equal to the lens focal point. The compact design (Figs. 1 and 2) allows the optical assembly to be easily removed and or replaced under repair conditions leaving the magnet and vacuum assemblies untouched. The optical scan mechanism's fast settling time and high repeatability,  $\pm 0.00025^\circ$  with  $80^\circ/\text{sec}$  travel, allows the system to collect data at a maximum rate of 30Hz limited by the embedded laser pulse rate.

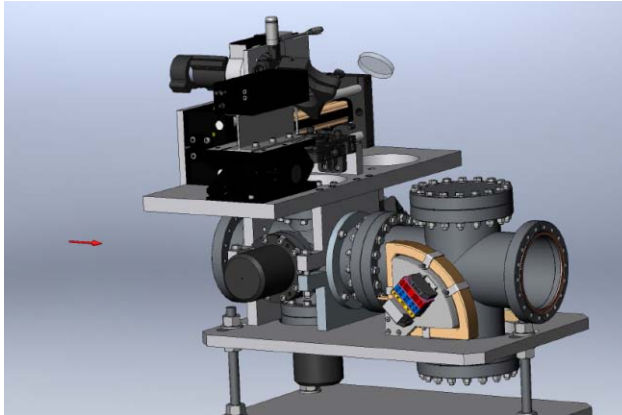

Fig. 2: Another look at the LPM at SNS.

Careful modeling of the optical system shows that the focal point of the laser beam, nominally 20–40  $\mu\text{m}$ , stays well within desired size and intensity throughout the scanned region (Fig. 3) with only small distortion at the outside edges of the proposed  $\pm 35\text{-mm}$  scanning range.

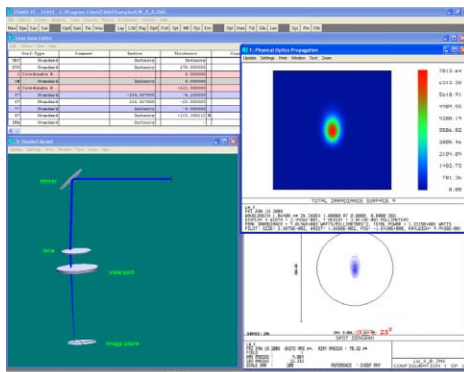

Fig. 3: Modeling of beam size and intensity.

The extreme edges of the scanning region modeled at 32mm from the center of the  $H_0$  beam show a distortion due to the edge effects of the bi convex singlet. This distortion elongates the laser spot at the interaction point but maintains an acceptable spot size and intensity. Careful measurements will be made in this area to determine if any profile signal degradation

occurs from this distortion. The modeled laser spot size appears in Fig.4.

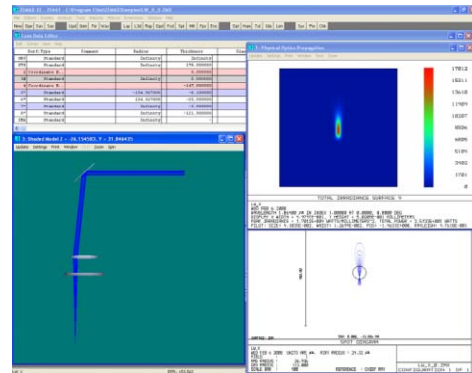

Fig. 4: Modeled laser spot size.

Several experiments have been added to the prototype assembly in order to facilitate additional information regarding the efficiency and operation of the LPM device. The high-frequency faraday cup is removed and a camera and scintillator are added temporarily allowing experimenters to capture and analyze the electron shower from the laser neutralization process. It is hoped such information may allow the designers to improve the faraday cup and magnet design.

## EMITTANCE MEASUREMENT

Initially, a CsI Ti coated aluminum scintillator will be mounted in the collection vessel approximately 11 meters from the LPM. This vessel is placed in the LINAC dump line of the SNS accelerator taking advantage of the systems juxtaposition with the first ring injection dipole steering magnet. This magnet will act as the separator for laser-neutralized protons as the unaffected  $H_0$  beam representing the majority of the SNS beam will continue on to the ring. Recently neutralized  $H_0$  protons will strike the scintillator and the image will be collected using a 200-fps CMOS camera. Figure 5 shows a model of the  $H_0$  beam intensity profile expected at the interface of the scintillator/harp collection point.

Prior to analysis of the efficiency of the laser slit, the scintillator and camera system will be used to determine if any stray  $H_0$  beam is in the LINAC dump from alternative sources. If there is significant evidence of any residual  $H_0$  present in the proton beam prior to neutralization. Any significant levels of non LPM generated  $H_0$  would make the use of a scintillator impractical. At this point the emittance collection device will switch to a more traditional electronically gated wire harp assembly. About 0.75 mrad resolution is needed,

for Harps with 0.75 mm inter-wire spacing, about 10 meter drift space is required. The harp assembly under construction is an array of 32 tungsten wires. A maximum 3% of proton beam is neutralized for a 0.02 mm-wide laser wire, indicating that 0.2~0.3% or less will be intercepted by a single harp wire. Given these system parameters, we modeled the expected SNS beam profile at the proposed collection site using ORBIT software as shown in Fig. 6. The estimated total emittance scanning range is +/- 2cm.

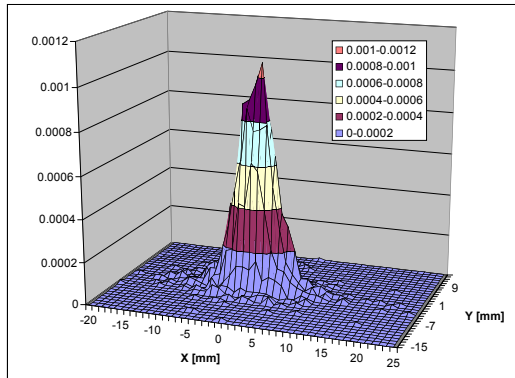

Fig. 5: Model of the H<sub>0</sub> beam intensity profile expected at the interface of the scintillator/harp collection point.

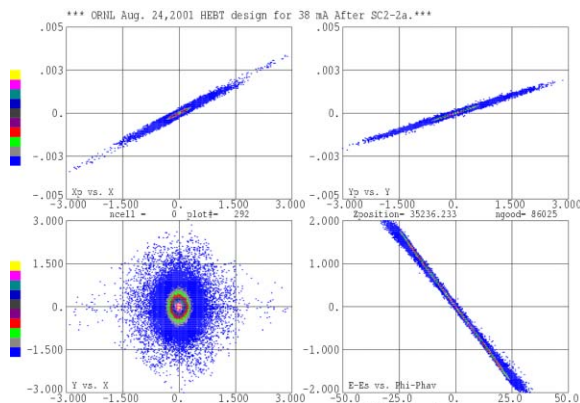

Fig. 6: ORBIT model of SNS beam profile at proposed collection site.

The region of interest is approximately 4 cm, with the majority ROI located within 3 cm. This model simulates the expected emittance when collected ten meters downstream from the LPM.

## CONCLUSION

The design has passed all of the reviews to date and we have started assembling the LPM and ECD in the lab. The vacuum vessels will be installed this summer during a normal operations maintenance period, with initial experiments to measure the existence of stray H0 and collect information on the stripped electron spray pattern into the Faraday cup to start in early September. After reviewing the operation of the system we intend to collect parasitically the emittance of the SNS beam by January of 2009.

## REFERENCES

- [1] A.Ehrlich, J.Galtz, P.Strehl, GSI Gesellschaft für Schwerionenphysik, Darmstadt 1974, GSI-PB-3-74.
- [2] V.W.Yuan *et al.*, "Measurement of longitudinal phase space in an accelerated H-beam", Nucl. Instr. Meth., A329, (1993).
- [3] R.C.Conolly *et al.*, "A transverse phase-space measurement technique for high-brightness Hbeams", Nucl. Instr. Meth., A312, (1992).
- [4] R. Connolly, P. Cameron, J. Cupolo, M. Grau, M. Kesselman, C-J. Liaw, R. Sikora, "JACoW, Laser profile measurements of an H- beam", DIPAC'01, Grenoble, May 2001, p.114, <http://www.jacow.org>.
- [5] T. Tomisawa *et al.*, Proc. of DIPAC 2005, POW018.
- [6] M. A. Plum *et al.*, Proc. of DIPAC 2003, IT08.
- [7] C.Gabor et al. "Status Experimental Results of a non-destructive emittance measurement device for H-beams", Proceedings of 2005 Particle Accelerator Conference, Knoxville Tennessee.