

# STATUS OF THE RE-ENTRANT CAVITY BEAM POSITION MONITOR FOR THE EUROPEAN XFEL PROJECT

C. Simon<sup>#</sup>, O. Napoly, CEA-Saclay/DSM/Irfu, Gif sur Yvette, France  
J-P. Prestel, N. Rouvière, CNRS-IN2P3-IPN, Orsay, France.

## Abstract

The European XFEL is a research facility, currently under construction in Germany. It is based on a superconducting electron linac including about 100 cryomodules based on the TESLA technology. Each cryomodule is equipped with a beam position monitor connected to a quadrupole at the high-energy end of the cavity string. Around one third of cold BPMs will be re-entrant RF cavities. This contribution describes the present status of the cold re-entrant cavity BPM and presents the measurements performed with BPM pickup and electronics prototypes.

## INTRODUCTION

The European XFEL (E-XFEL) is a project to construct an X-ray Free-Electron-Laser international user facility close to DESY in Hamburg [1]. This machine, which is based on the TESLA superconducting RF technology, will accelerate electron beams up to 17.5 GeV at a repetition rate of 10 Hz. The first beam is expected in 2014.

To provide position and charge information along the linac, about 450 Beam Position Monitors (BPM) will be installed. Depending on the BPM location and the performance requirements, different BPM types will be used. In the accelerator modules, two types of BPMs will be installed: button BPMs [2] and re-entrant cavity BPMs. These latest represent 30 % of the cold BPMs. Independent of the type of BPM, they will have a common mechanical interface and the same specifications shown in table 1.

Table 1: Cold BPM parameters

Parameter	Value
Beam pipe diameter	78 mm
Length	170 mm
Single bunch resolution (RMS)	50 $\mu\text{m}$
Operation range for maximum resolution	$\pm 3$ mm
Transverse Alignment Tolerance (RMS)	300 $\mu\text{m}$

One re-entrant BPM is already installed in a warm section of the FLASH linac [3], and achieves 4  $\mu\text{m}$  resolution over a dynamic range of  $\pm 5$  mm [4].

In this paper, the status of the XFEL cold re-entrant BPM is presented. A prototype has been manufactured to be installed in an XFEL prototype cryomodule and an

electronics based on a Printed Circuit Board (PCB) will be discussed.

## RE-ENTRANT BPM MECHANICS

The length of the re-entrant cavity is 170 mm to respect the constraints imposed by the cryomodule and its aperture is 78 mm (see Fig. 1). It is composed of two parts, in stainless steel, welded together by an electron beam. Flanges are manufactured in the same blocks to get the alignment tolerances. The alignment of the BPM is done by dowel pins with respect to the cold magnet.

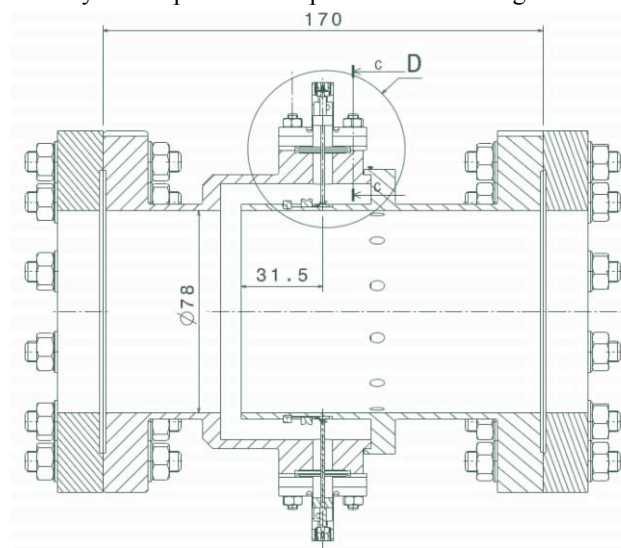

Figure 1: Drawing of the re-entrant cavity BPM.

In order to avoid hydrogen out-gassing, a heat treatment at 950 °C for 2 hours is applied to the BPM cavity. Since it is connected to a cold magnet, the BPM will be at a temperature close to the 4 K level and will be mounted in a clean room. For an effective cleaning, twelve holes of 5 mm diameter are drilled at the end of the re-entrant part.

To reduce the cryo-losses, a 12  $\mu\text{m}$  thick copper coating is deposited on the inner beam pipe. Then, a heat treatment at 400 °C is done to check the copper surface and test the contact of copper and steel.

Each antenna, which is a combination of stainless steel, molybdenum and alumina  $\text{Al}_2\text{O}_3$  ceramic brazed, is mounted on the cavity via a CF16 flange. They have to pass cryogenic shocks and to fulfil the conditions of Ultra High Vacuum (UHV). Four copper-beryllium radio-frequency contacts are also welded in the inner cylinder of the cavity to ensure the electrical conduction between the feedthrough inner conductors and the cavity.

<sup>#</sup>claire.simon@cea.fr

## RE-ENTRANT BPM INSTALLED IN A XFEL CRYMODULE

The re-entrant BPM will be mounted in an XFEL cryomodule and connected to a cold quadrupole at the high-energy end of the cavity string as shown in Fig. 2.

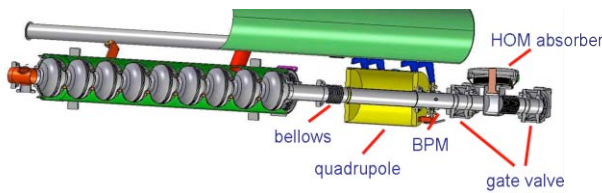

Figure 2: Layout of the downstream end of the XFEL cryomodule.

In 2009, one prototype of re-entrant BPM with copper coating has been manufactured and installed in a prototype cryomodule. Transverse alignment of two parts composing the cavity was measured around 74  $\mu\text{m}$  and the leak rate measured at  $4.10^{-10}$  mbar.l/s. During the fabrication process, a few manufacturing, welding and, copper coating problems appeared. A severe control has to be carried out for the different steps.

The RF measurements were done in laboratory and are presented in Table 2.

Table 2: BPM RF characteristics.

	Frequency (MHz)	$Q_{\text{ext}}$
	Measured in lab.	Measured in lab.
Monopole mode	1272	22.3
Dipole mode	1732	47

Frequencies shifted by around 10 MHz in comparison with the simulation results and the measurements done on the re-entrant BPM installed on the FLASH linac [5]. This difference could be due to the cavity geometry. For the next prototype, tolerances were tightened. Cross-talk was measured around 31.8 dB. These RF measurements can be used in the quality control process of the series.

This prototype has been sent to DESY, connected in a clean room to the quadrupole and mounted in an XFEL prototype cryomodule (see Fig. 3).

## SIGNAL PROCESSING ELECTRONICS

### Electronics concept

The signal processing of the re-entrant BPM uses a single stage down conversion to obtain  $\Delta/\Sigma$ . As shown Fig. 4, the difference  $\Delta$  and sum  $\Sigma$  signals are obtained from a passive 4-ports  $180^\circ$  hybrid which will be installed in a box mounted at the side of the cryomodule.

Each coupler is connected to each pair of opposite antennas and transmits the signals to the radio-frequency front-end electronics via some 30 m long semi-rigid cables. The Radio-Frequency front-end (RFFE) electronics is based on a PCB with surface mount components. Because of the low external quality factor, the single bunch response of the cavity has to be broadened before its acquisition.

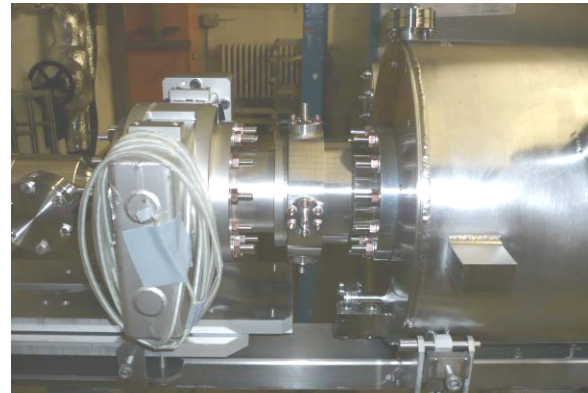

Figure 3: Re-entrant BPM mounted in the XFEL prototype cryomodule.

On the  $\Delta$  channel, the rejection of the monopole mode signal, which does not depend on the beam position, is produced by a hybrid coupler, a band-pass filter centred at the dipole mode frequency and an in-phase/quadrature-phase (I/Q) demodulation of the dipole mode signal. A reference signal from the linac machine system is combined with a phase-locked loop (PLL) to generate a local oscillator (LO) signal to the mixers around the dipole mode frequency. The I/Q demodulator is composed of mixers used for systems with a high dynamic range, and of  $90^\circ$  hybrids couplers chosen for their good phase and amplitude unbalances.

To protect the downstream active electronics from possible high output power from the antennae, an RF limiter is used on each channel.

The  $\Sigma$  signal, which depends on the beam intensity, is measured by a direct detection using a Schottky diode detector.

On each channel, the gain is adjusted thanks to variable attenuators to avoid saturation from ADCs in different operating modes of the accelerator.

The output  $\Sigma$  signal and I/Q IF signals:  $I_x$ ,  $Q_x$ ,  $I_y$  and  $Q_y$ , detected by the signal processing electronics are differential signals. They deliver to ADCs a pulsed signal of width around 40 ns with a shape close to a Gaussian shape [5] and should have amplitude in the range  $\pm 1.25$  V.

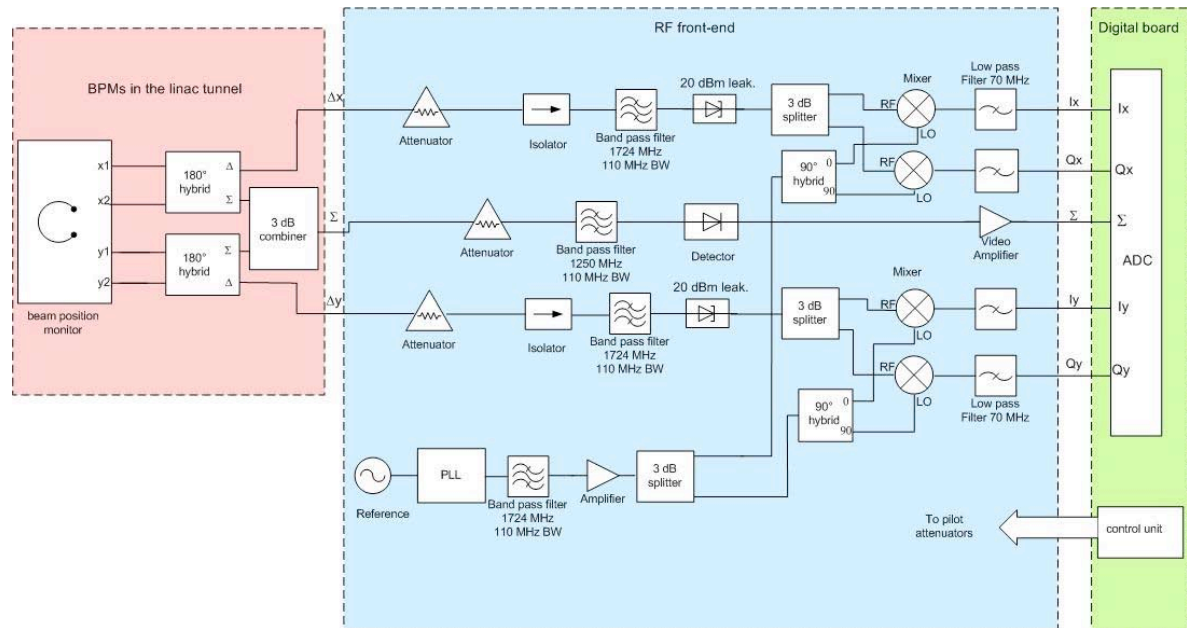

Figure 4: RF signal processing electronics.

The sampling and the interface to the control-system are carried by 16 bits ADCs digital electronics operating at 160 Msps designed by PSI. The phase of the ADC sample clock has to be carefully adjusted to input signals to get correct measurements of a pulsed signal and to determine the peak values of the output signals from the RFFE.

A modular system called Modular BPM Unit (MBU) [6] contains two re-entrant BPM RFFE electronics which occupies one slot each; two additional slots in the MBU are foreseen for the Generic PSI ADC Carrier Board (GPAC) with its ADC mezzanines. The mechanical form of the re-entrant RFFE is compatible to VME64x.

### Preliminary test of the electronics

A re-entrant RFFE printed circuit board (Fig. 5) has been designed in 2009, with a particular attention to the design of the IQ demodulator.

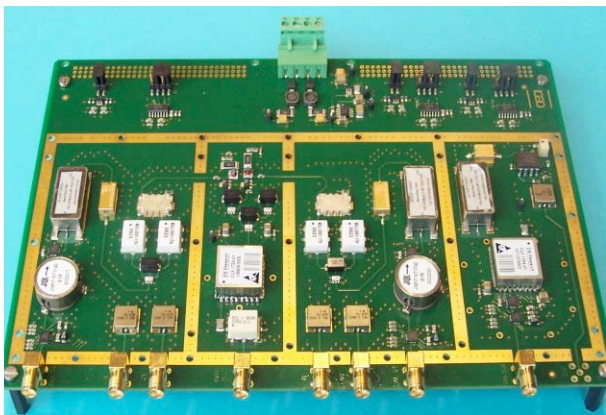

Figure 5: Re-entrant RFFE board.

To test this RFFE electronics prototype, first measurements have been carried out in laboratory. A test bench is created with a pulse generator. Pulsed signals at the monopole and dipole mode frequencies were injected to the RFFE board with amplitude corresponding to an offset of 0.5 mm. The output signals  $I_x$ ,  $Q_x$ ,  $I_y$ ,  $Q_y$  and  $\Sigma$  deliver information to ADCs and the amplitude is determined by the following equation (see Eq 1).

$$A_n = \sqrt{(I_n - I_{ADC})^2 + (Q_n - Q_{ADC})^2} \quad (1)$$

where  $n$  is the sample and  $I_{ADC}$  and  $Q_{ADC}$  are the offsets of ADCs. The RMS jitter calculated by the standard deviation is around  $0.68 \mu\text{m}$  on the X channel, and around  $0.91 \mu\text{m}$  on the Y channel.

## CONCLUSION

The status of the re-entrant BPM is presented in this paper. On the last prototype, the RF frequencies being shifted of a few MHz, tolerances of the cavity were tightened. A better quality control will be done to check each step of the fabrication process.

First lab test results of the RFFE board are promising for the resolution that needs to be achieved. However, this electronics was designed with a reference frequency of 9.028 MHz while 216 MHz should be used for the XFEL machine. Some components will be therefore, changed. Moreover, the lab test does not include the environment noise which is generally predominant. Beam tests with the re-entrant cavity, RFFE electronics and digital back-end electronics in their final version are required in order to

check the impact of that environment on the beam position.

### ACKNOWLEDGMENTS

We thank our colleagues from DESY and PSI: D. Nölle, S. Vilcins, B. Keil, R. Kramert for their support and the fruitful discussions on the BPMs. We wish to acknowledge MDI, MKS and MVS teams at DESY for the installation of BPM in the XFEL prototype cryomodule. Finally, we would like to thank all our colleagues from CEA Saclay for their advices and their help on this project.

### REFERENCES

- [1] “XFEL Technical Design Report”, DESY 2006-097, <http://xfel.desy.de>.
- [2] D. Nölle et al, “BPMs for the XFEL cryomodule”, DIPAC07, Venice.
- [3] V. Ayvazyan et al., Eur. Phys. J. D 37, 297 (2006).
- [4] C. Simon et al, “Beam position monitors using a re-entrant cavity”, DIPAC07, Venice.
- [5] C. Simon, et al., “Performance of a reentrant cavity beam position monitor”, Physical review special topics – accelerators and beams 11, 082802 (2008).
- [6] B. Keil, “Infrastructure Requirements for the European XFEL Beam Position Monitor and Intra-Bunch Train Feedback System Electronics.”