

ADC CONSIDERATIONS AND ANALYSIS FOR BAND PASS SAMPLING SYSTEMS

Alfred J. DellaPenna Jr., Brookhaven National Laboratory, Upton, NY 11973, U.S.A.

Abstract

With increasing demand of acquiring data at high speed with high resolution, more digitizers have become available for this purpose. With digitizers becoming faster and faster at higher data rates with higher resolutions, the factors in choosing the proper digitizer for a design is not just the number of bits. Deciding factors include jitter, maximization of the effective number of bits (ENOB) and linearity over the band of interest, and most importantly phase noise. Does the part you are evaluating match with the data sheet? If not, what is different in your test setup? (Your evaluation can only be as good as the equipment you are using to test the device.) With the availability of evaluation boards from almost any of the ADC vendors, a more in-depth evaluation can be performed fairly easily. Even the GUI interface is usually included with the evaluation board. So for a small investment on several choices, one can make a side by side comparison and see actual results.

INSTRUMENT SETUP

Our initial setup is illustrated in Figure 1. We used a single tone (500 Mhz) from a HP signal generator as the analog input. The digitizer clock, which requires the more stable (lower jitter) signal, was supplied by the Rohde & Schwarz SMA100A signal generator. Along with the evaluation boards a mating digital interface was purchased for each so we could utilize the graphical user interface that the vendor had created. The interface to the computer was through a USB cable. The software was downloaded from the vendor’s website.

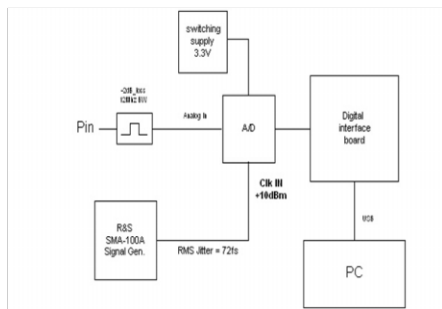

Figure 1: Digitizer setup. The analog input was from an Agilent N5181A. Software was downloaded from the digitizer vendor.

The onboard jumpers were usually set up at the factory; however, we did find that the evaluation boards allowed many different setup configurations. Choosing a setup

that worked best for us took some time. Finally it was time to take some data.

We wanted to be sure it was a fair side by side evaluation of each digitizer. All of the evaluation boards had their analog input “protected” by limiting resistors; because of this, the same input signal did not use the same scale from one digitizer to another. This required us to either adjust the input to compare similar levels at the input to the digitizer, or modify the evaluation board itself (removing the limiting resistors). These modifications made the setup of all evaluation boards as close as possible, all running off the same supply and signal generators. Power sweeps were taken from -90 to +10 dBm and the associated plots were compared to each other. Figures 2-5 show the resultant Fast Fourier Transforms from each digitizer we were evaluating.

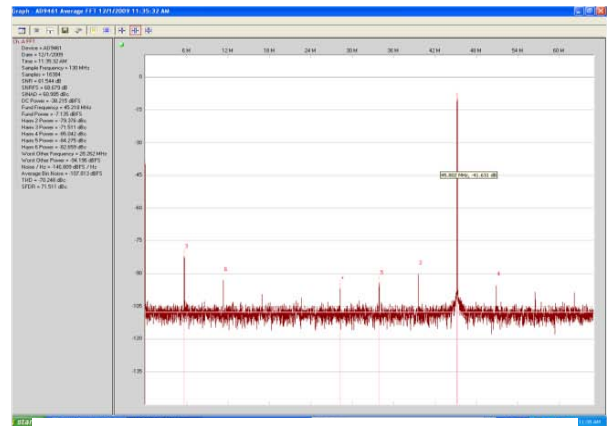

Figure 2: Analog Devices AF9461 FFT, power in +10 dBm.

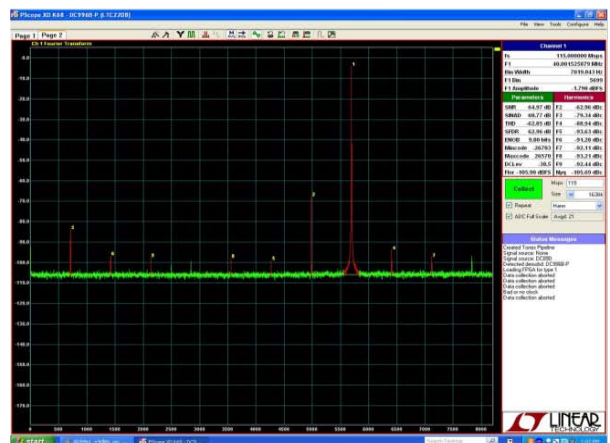

Figure 3: Linear Technology LTC2208 FFT, power in +10 dBm.

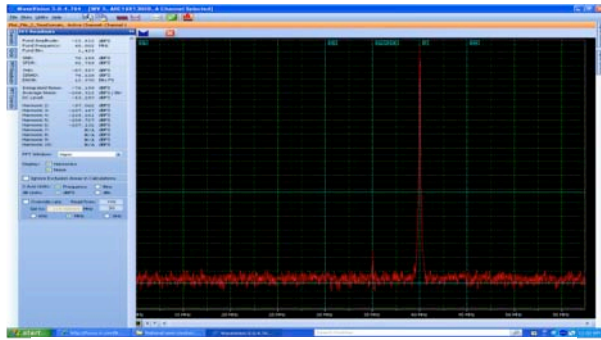

Figure 4: National Semiconductor ADC16V130 FFT, power in +10 dBm.

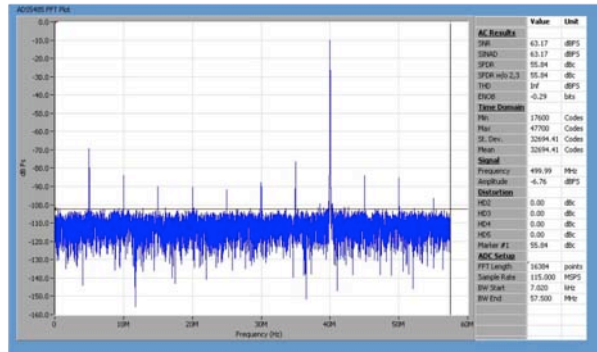

Figure 5: Texas Instruments ADS5485 FFT, power in +10 dBm.

MEASUREMENT OPTIONS

Almost all the digitizer software has different options, e.g., single tone, multi-tone, and time domain. Even masking of portions of the spectrum was available. In our application we worked in the frequency domain to look at the harmonic distortion in the spectrum. The signal level of the clock for the digitizer was also very critical; a low signal level on the clock would directly affect the SNR/SINAD results. We found that a signal level of +10dbm worked very well. For the analog input signal level, the input was brought up until the level exceeded the compression point of the digitizer (P1db). Then it was backed off by 1 or 2 dB. This ensured us of using the full range of the digitizer.

RESULTS

We did a side by side jitter measurement of the two signal generators. The associated phase noise plots along with jitter numbers are in Figures 6 and 7.

The data from all four plots, along with simulated data from the analog device part, were put into an Excel spreadsheet so that we could see the entire picture. Parameters other than SINAD and SNR were put into this spreadsheet as well. Figure 8 shows the results.

Instrumentation

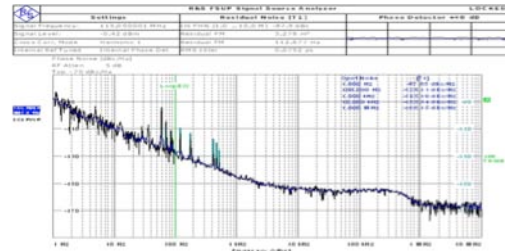

Figure 6: Phase noise of Rohde & Schwarz SMA100A.

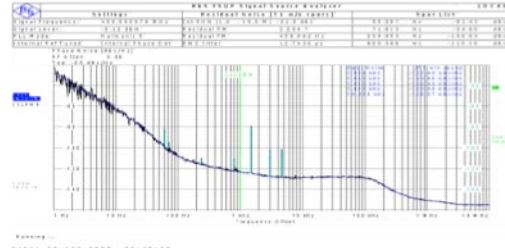

Figure 7: Phase noise of Agilent N5181A.

CONCLUSION

The data conversion market has made very user friendly advances in the way one can evaluate a product. Even the digital interface to the PC world has been handled. The GUI interface, and the available options to perform any number of tests on the product, are already built in. One thing to be aware of is the different front end protection before the digitizer; this will change the level that one digitizer sees compared to the other. You can either compensate for it or modify the board to ensure all tests are one to one. Another thing to watch for is that all the evaluation boards used here are connected to the PC through a USB connector. Using a slow USB 1.1 port may not work—we have seen it on two of the evaluation boards we tested. From our results, in our particular situation, we found that the Linear Devices LT2208 worked best for our application.

ACKNOWLEDGEMENTS

Kurt Vetter for his extremely helpful insight in so many matters. Belkacem Bacha, Marshall Maggipinto for their exceptional work in setting up evaluations and taking data.

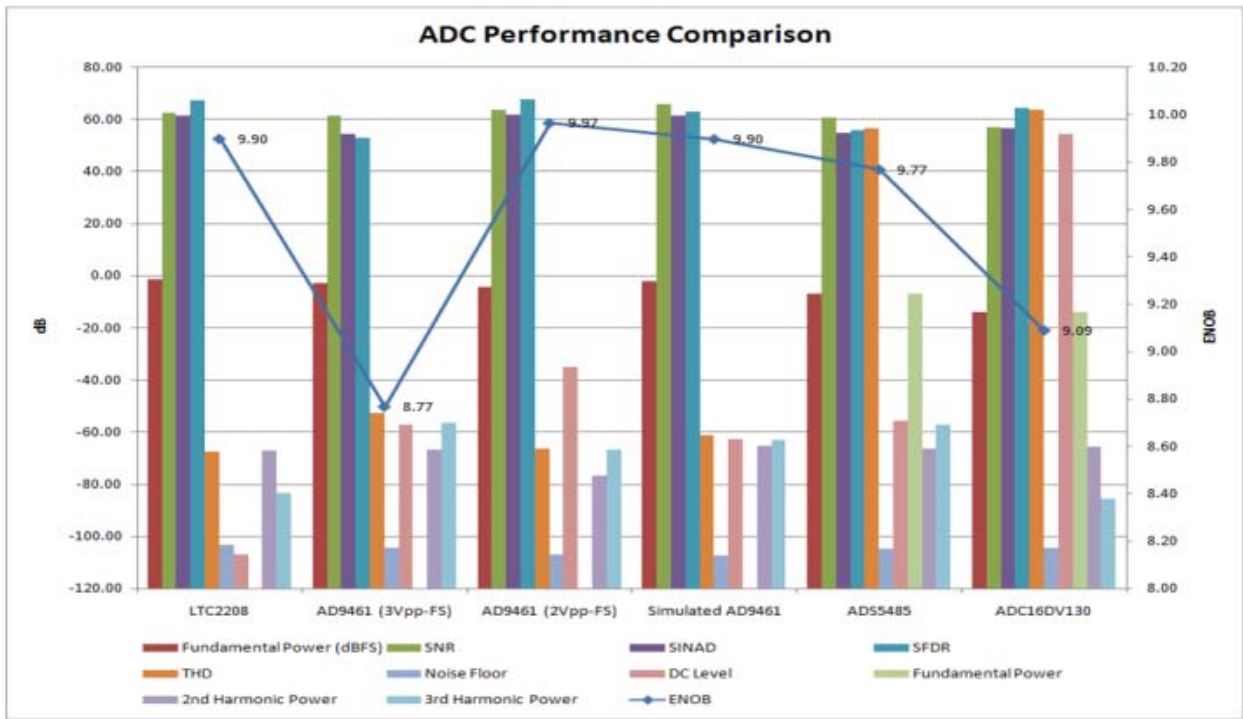

Figure 8: Integrated results of our tests.