

DESIGN AND DRIFT PERFORMANCE OF THE FLASH MASTER LASER OSCILLATOR RF-LOCK

K. Hacker, V. Arsov*, M. Bock, M. Felber, P. Gessler, F. Loehl[#], F. Ludwig, H. Schlarb, B. Schmidt, A. Winter⁺, J. Zemella, DESY, Hamburg, Germany
 S. Schulz, L. Wissmann, Hamburg University, Hamburg, Germany

Abstract

The heartbeat of the FLASH optical synchronization system, the Master Laser Oscillator (MLO), must be synchronized with the Master RF Oscillator (MO) via a circuit that converts the timing information in the pulses of the laser into an RF signal that can be phase-locked to the RF output of the MO. The Phase Lock Loop (PLL) is closed via a Digital Signal Processor (DSP) and has 77 fs out-of-loop drift performance over a 24 hour period with no disturbances in the climate controlled room. With amplitude drift stabilization of the laser and temperature control of the phase measurement chassis, the largest contributors to the drift of the PLL would be removed. With active temperature control of the RF phase measurement, an over-night stability of 5 fs was achieved. The design of the RF-circuit and its performance are presented here.

INTRODUCTION

The FLASH optical synchronization system is designed for high-precision timing applications that cannot be accomplished through RF distribution and stabilization techniques alone [1]. It is based on sub-picosecond-long optical pulses distributed on length-stabilized fiber-links to various diagnostic and laser stations. The pulses are produced by a Master Laser Oscillator (MLO) that is phase locked to a Master RF Oscillator (MO) through a Digital Signal Processing (DSP) regulation loop. The pulses from the MLO are impinged upon a 10 GHz photo-detector that resides directly within the laser housing. The photo-detector output is sent, via a 6 meter long RF-cable, to a rack containing phase measurement RF electronics in a chassis that is temperature stabilized to within 0.001 deg C (rms).

Designed to support two MLOs and two 1.3 GHz MLO-MO lock circuits, the schematic of the RF-lock box for MLO synchronization is shown in Fig. 1. One of the two identical circuits was used to lock the MLO to the MO and provide an in-loop measurement and the other was used for an out-of-loop measurement. In addition to the 1.3 GHz phase measurement circuits, a pair of AD8302 216 MHz phase and amplitude detection circuits are employed to provide a coarse reference against which bucket jumps of the PLL can be diagnosed. The MO reference is shifted with a vector modulator board that is controlled with a DAC. This functionality is used, for example, to measure the K-phi of the phase measurement.

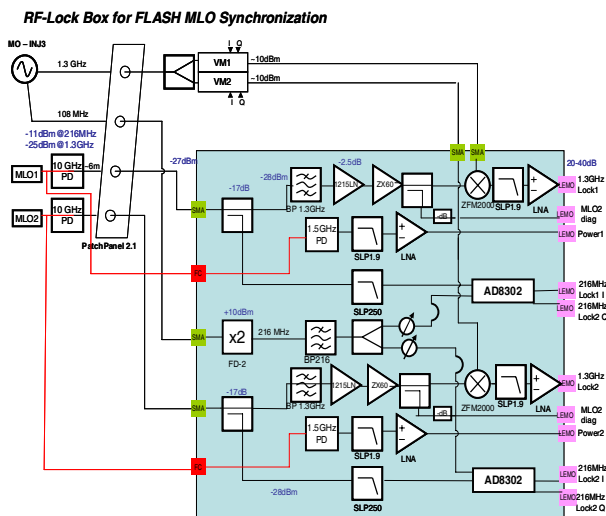

Figure 1: Schematic of MLO – MO phase measurements.

The drift of the RF phase measurement alone was below 5 fs in an undisturbed, climatized room with active temperature control within the chassis, but it jumped by 15 fs when people entered the room. When used in a DSP regulation loop, an out-of-loop drift of 77 fs was measured over an undisturbed 24 hour period. The out-of-loop drift was dominated by the effects of laser amplitude drift.

RF CHASSIS DESIGN

Temperature stability of the 1.3 GHz bandpass filters was the most critical requirement for long-term stability of the RF circuit. When cold air was sprayed on each individual component of the circuit, the most dramatic mixer output drift response was observed when the filter temperature was disturbed. Since it is undesirable to create temperature gradients throughout the RF circuit, a thermally conductive paste was applied to each component before it was fixed to a 4 mm thick aluminium plate shown in Fig. 2. The plate was supported by two 10 mm thick rectangular bars that each rested upon a pair of cylindrical posts. One of the posts was plastic and the other was aluminum, topped by a Peltier element that was sandwiched between the rectangular bar and the post and positioned directly underneath the 1.3 GHz filters. The heat from the Peltier travels down the metal post onto the base of the chassis which is cooled by a rack mounted fan.

Each Peltier element had its own temperature controller, not because this was required for thermal stability, but because the current load of each controller

Corresponding author: kirsten.hacker@desy.de
 * now at PSI, Switzerland
[#] now at Cornell University, Ithaca, NY, USA
⁺ now at ITER, Cadarache, France

was not sufficient to drive multiple Peltiers. The temperature controllers were mounted on the back wall of the chassis, along with a voltage regulator that produced +12V, -15V, and +15 V from a ± 20 V input. The ± 20 V was produced by one power supply, while the +5 V required by the temperature controller was produced separately, due to noise and current load considerations.

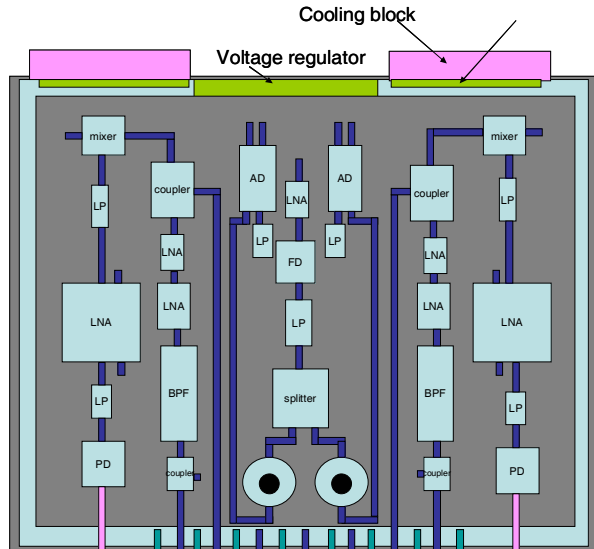

Figure 2: Sketch of upper and lower levels of RF chassis. The upper level supports the RF components while the lower level supports the thermal stability of the upper level. (LNA = Low Noise Amplifier, FD = Frequency Doubler, BPF = Band Pass Filter, LP = Low Pass Filter, PD = Photo-detector)

K-PHI MEASUREMENT

Every down-conversion scheme requires a measurement of the K-phi, the sensitivity of the output to changes of the input phase. There are several ways of measuring the K-phi, two of which are presented here.

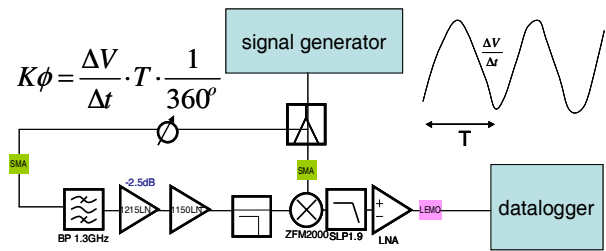

Figure 3: A method of measuring the K-phi of the 1.3GHz phase measurement.

If the RF and LO come from the same source, one can shift the phase of one relative to the other and thereby measure the K-phi, as shown in Fig. 3. The change in DC voltage at the output, as a function of phase, is the K-phi. Alternatively, if an unlocked source is mixed with a reference signal, the slope of the most linear part of the resulting sine wave is the K-phi. From either method, the K-phi for the circuit without amplification after the mixer is 3 mV/deg at 1.3 GHz. With amplification after the mixer, the K-phi for this 1.3 GHz circuit can be as much as 350 mV/deg, but it was reduced to ~80 mV/deg in order to match the input range of the ADC. The K-phi can vary between 60-90 mV/deg, depending on the laser amplitude and output power of the photo-detector.

BASEBAND NOISE MEASUREMENTS

The power supply, the voltage regulator, cable vibrations, and the amplifiers are the primary sources of baseband noise in a down-mixed signal from a signal generator (Fig. 4). The noise that affects the regulation loop is, however, primarily that which occurs at frequencies below 10 kHz, because this is the bandwidth of the MLO-PLL. For this frequency range, the choice of power supply was an easy way to improve noise performance. The choice of the brand of voltage regulator also proved to be critical to keep it from ringing [2].

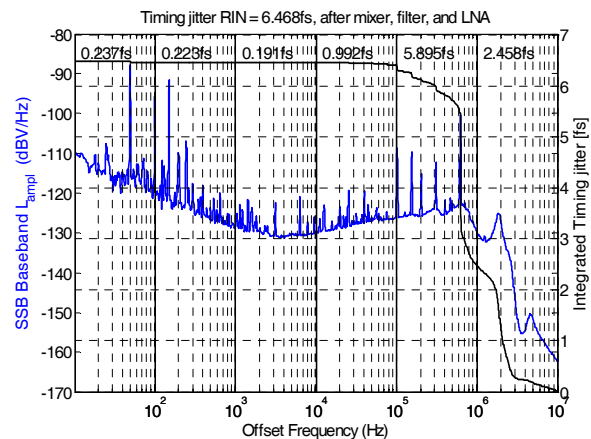

Figure 4: Baseband noise of the mixer output with amplification. Although high frequency noise is added through the amplifier, frequencies above 10 kHz are later filtered out in the regulation. The K-phi was 350 mV/deg.

RF CIRCUIT DRIFT MEASUREMENTS

The drift of the RF circuit can be significantly improved through active temperature stabilization with a Peltier element and a temperature controller. In Fig. 5, the drift of the circuit is shown with and without active temperature stabilization. Both measurements were carried out in the middle of the night with no disturbances. In the case where the temperature is stabilized below 0.002 degrees C (rms), there is minimal mixer output drift, whereas, in the case without regulation, the temperature drifts by 0.03 degrees C and the signal drifts by 10 fs.

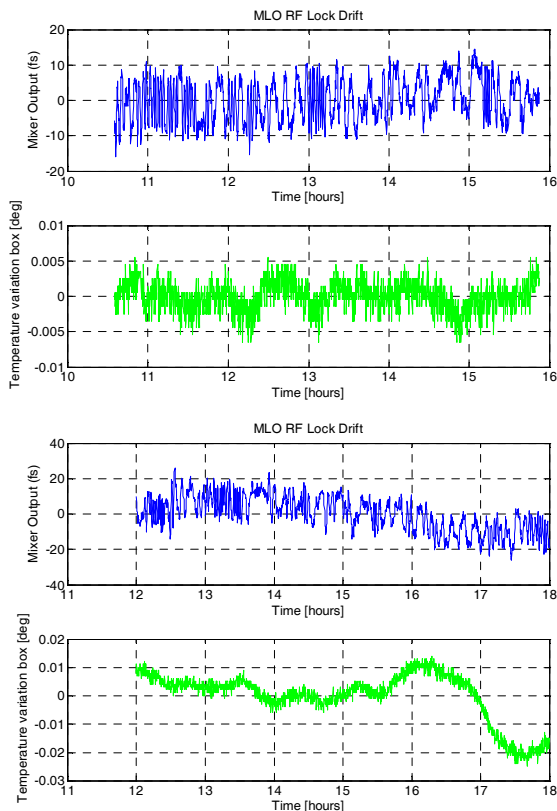

Figure 5: Drift of RF circuit with (top) and without (bottom) active temperature stabilization.

Figure 6 shows the drift stability under conditions where several people were working in the room. The active temperature stabilization limited the temperature changes to 0.3 degrees C with 20 fs of drift. Without such stabilization, the mixer output drifts by more than 100 fs under similar conditions.

The 20 fs peak-to-peak mixer output jitter in Fig. 5 was primarily due to vibrations on the 2 meter long RF cables connecting the RF chassis to the signal source. When they were shortened and fixed in Fig. 6, the jitter was reduced to a few femtoseconds peak-to-peak. The vector modulator was not included in the measurement.

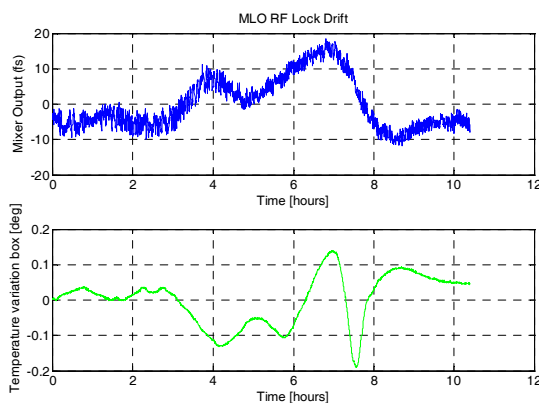

Figure 6: Phase stability measurement with 4 people working in the room and active temperature stabilization. Without active temperature stabilization, the same situation would cause more than 100 fs drift.

In addition to active temperature control, individually testing circuit elements for temperature sensitivity allowed for improvements in the design. For example, the ZRL 1150 LN+ amplifier showed ~10 times the temperature sensitivity of the ZX60-300 LN+. Its replacement improved both the short- and long-term drift characteristics.

IN-LOOP MEASUREMENTS

The drift of an in-loop measurement is, by necessity, zero, because the regulation removes drifts. The intrinsic noise of the photo-detectors, the response of the photo-detectors to fast changes in the amplitude of the laser [3], electronics noise, and the speed of the regulation, however, determine the jitter and stability of the loop. Noise that is faster than 10 kHz does not have an impact on the loop, due to the DSP regulation speed.

The upper-half of Fig. 7 shows the closed-loop measurement setup in which the laser pulses are incident upon a photo-detector whose output is filtered, amplified and mixed with the 1.3 GHz from the MO. The mixer output is filtered and amplified once again and then sent to an ADC/DSP/DAC regulation system that controls the voltage of a piezo-driver that modulates the position of a mirror in the laser cavity.

OUT-OF-LOOP MEASUREMENTS

Two identical down-mixing circuits were built in the same chassis because two MLOs are planned for the synchronization system. For the case of an out-of-loop measurement setup, shown in Fig. 7, one phase measurement circuit was used for an MLO-MO PLL and the other was used for the out-of-loop measurement. Because two separate photo-detectors were used and the DSP laser amplitude feedback was not available, the setup actually used in the out-of-loop measurement presented here was not optimal. The phase stability measurement was negatively affected by temperature differences between the photo-detectors and differences in how each photo-detector responds to changes in the laser amplitude.

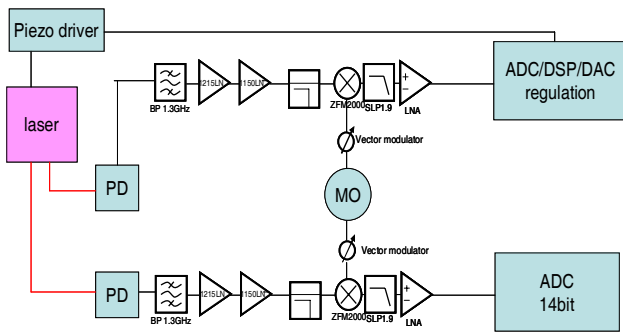

Figure 7: Out-of-loop setup. One photo-detector/down-mixer chain is used for the regulation and the other is used to measure the resulting phase stability.

The response of photo-detectors to changes in temperature [4] and the response of the photo-detectors to changes in the amplitude of the laser [3] vary significantly between individual photo-detectors, even if they are the same brand. We can still make an estimate of ~ 340 fs/deg C and ~ 4 ps/mW at 4 mW for their temperature and amplitude responses. The laser amplitude drifted by 0.3%, as shown in Fig. 8, over the course of the same measurement shown in Fig. 9. This laser amplitude drift could account for ~ 50 fs of the 77 fs drift in the out-of-loop measurement. The temperature stability of the photo-detectors was better than the 0.01 deg threshold of the measurement system.

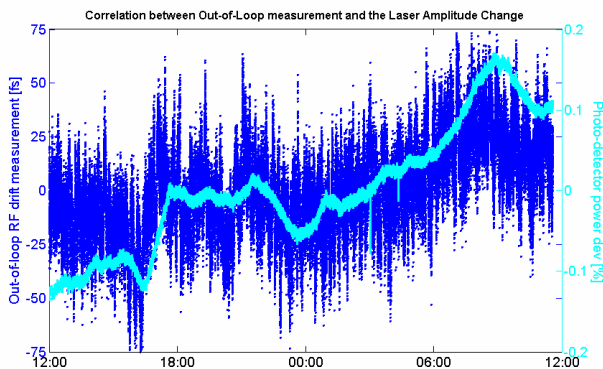

Figure 8: Laser amplitude drift can account for 50 fs of the out-of-loop drift.

The out-of-loop measurement was conducted with two different lasers, one of which often generated two pulses when it should only have generated one. When the laser was in a double-pulse mode, the out-of-loop measurement produced drifts and jumps of hundreds of femtoseconds, due to changes in the timing relationship between the double-pulses. When the other was used, no double pulses were observed and the drift performance was very stable, as presented here.

It should be noted that in Fig. 9, the active temperature control of the chassis was off due to a temporary air-flow control arrangement in the rack. This increased the rack temperature by ~ 5 degrees and reduced the effectiveness of the Peltier system. It is expected that when the chassis temperature control is re-commissioned, the drifts that are

correlated with rack temperature will be largely suppressed, as evidenced by the results shown in Figs. 5 and 6.

Cable vibrations seemed to have a large effect on the rms jitter of the out-of-loop measurement, but were not effectively measured. Vector modulator noise and drift were also not studied, but it is expected to affect drift performance.

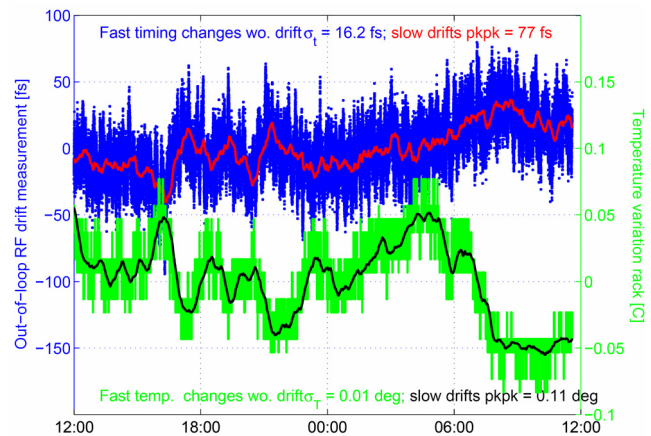

Figure 9: Out-of-loop drift performance on a quiet night in a climatized room.

The 16 fs rms jitter and 77 fs peak-to-peak drift of the out-of loop measurement from Fig. 9 are not dominated by the noise or drift from the RF phase measurement (2 fs rms, 30 fs drift), but rather by the laser amplitude drifts and noise (50 fs drift). The RF phase measurement contributed ~ 30 fs of drift in the above measurement in an undisturbed, climatized room without in-chassis temperature control, but it would contribute only ~ 5 fs with the in-chassis temperature control. The largest improvement in RF-lock performance could be gained through DSP laser amplitude stabilization.

CONCLUSIONS

- Drift stability of MLO-MO PLL is currently determined by the laser amplitude stability.
- Stabilizing the in-chassis temperature of the phase measurement can reduce night-time drifts to 5 fs from 20 fs and can reduce the impact of people working in the room to below 20 fs instead of the 100 fs drift that occurs without it.

REFERENCES

- [1] X-FEL Technical Design Report Sect. 4.8 2006.
- [2] K.H. Matthiesen, Personal communication.
- [3] J. Mueller, Master's Thesis, DESY 2007.
- [4] B. Lorbeer, Master's Thesis, DESY 2008.
- [5] S. Schulz, This conference WEPC72.