

APPLICATION AND DESIGN OF THE STREAK AND TV READOUT SYSTEMS AT PITZ

M. Mahgoub^{*}, G. Asova[†], J. Baehr, H.J. Grabosch, M. Groß, L. Hakobyan, I. Isaev[‡], Y. Ivanisenko, M. Khojoyan[§], G. Klemz, M. Krasilnikov, D. Maljutin, A. Oppelt, M. Otevrel, B. Petrosyan, S. Rimjaem, K. Rosbach, F. Stephan, G. Vashchenko, DESY, 15738 Zeuthen, Germany
J. Rönsch-Schulenburg, Hamburg University, Luruper Chaussee 149, 22761 Hamburg, Germany
D. Richter, HZB, 12489 Berlin, Germany

Abstract

The main target of the Photo Injector Test facility at DESY, location Zeuthen (PITZ) is to optimize photoelectron injectors for short wavelength Free Electron Lasers (FELs). The distribution of the electron bunch in the longitudinal phase space was investigated using a streak camera system and compared to the measured momentum distribution using the Momentum And Momentum spread Analysis tool MAMA.

The design and structure of the TV-system for the new extension of the PITZ facility DISP3 is presented, which provides a direct and real-time imaging. The Video signal from the TV-system can be directly viewed, stored and analyzed.

INTRODUCTION

The Photo Injector Test facility at DESY, location Zeuthen (PITZ) was built to develop and experimentally optimize photoelectron injectors for short wavelength Free Electron Lasers (FELs) like FLASH and the European XFEL in Hamburg Germany. Electrons can be accelerated up to momenta of about 25 MeV/c. The PITZ facility is capable to generate long trains of electron bunches. Optimization of all injector parameters such as emittance and longitudinal properties of the electron bunch is needed. A streak camera system is used to investigate the complete longitudinal phase space distribution of the electron bunch with an accuracy of few ps. In this system the electron beam penetrates Silica Aerogel radiators or Optical Transition Radiation screens (OTR) and produces light, which is transported by an optical line to the streak camera. Beside the streak camera system a TV system is used to observe the electron beam during operation. In this system Yttrium Aluminum Garnet (YAG) and Optical Transition Radiation (OTR) screens are used to produce a direct image of the electron beam.

^{*} Mahmoud.Mahgoub@desy.de

[†] On leave from INRNE, BAS, Sofia, Bulgaria

[‡] On leave from MEFPhI, Moscow, Russia

[§] On leave from YerPhI, Yerevan, Armenia

LONGITUDINAL PHASE SPACE MEASUREMENTS

The Principle of the Streak Camera Measurements

A streak camera is an instrument for measuring the intensity of a light pulse with high temporal resolution. A streak camera implies a transforming the temporal profile of a light pulse into a spatial profile. By directing the light pulse onto a photocathode, photons produce electrons via the photoelectric effect. The electrons are deflected by a time varying voltage produced by a pair of plates, which deflects the electrons sideways causing a time-varying deflection of the light across the width of the detector. Electrons are converted again into photons by using a fluorescent screen. A linear detector, such as a Charge-Coupled Device (CCD camera) is used to measure the streak pattern on the fluorescent screen, and thus the temporal profile of the light pulse [1].

PITZ Setup

The current setup (PITZ 1.8) has four stations for the longitudinal phase space measurements. DISP1.Scr1 and LOW.Scr3 in the LOW section, HIGH1.Scr2 and DISP2.Scr1 in the HIGH1 section (Fig. 1). The first and the fourth stations, were designed to collect and detect a part of the cone of the emitted light. They are based in the dispersive arms DISP1 and DISP2, respectively. The second and the third were designed to collect the full cone of the emitted Cherenkov light [3]. Those screen stations are equipped with a Silica Aerogel radiator with refractive index in the range of 1.008 up to 1.05 and thickness of 2 mm, as well as OTR screens, where the electron beam penetrates the radiators and produces light. The light is transported by an optical line to the streak camera [1]. The optical transmission line of about 27 m in length is designed to have is design high transverse resolution, minimum light losses and a minimum number of optical elements. The emitted light distribution presents the charge distribution in the electron bunch.

Results

Figure 2 shows the streak image for the electron bunch (bottom) compared to the results from MAMA program

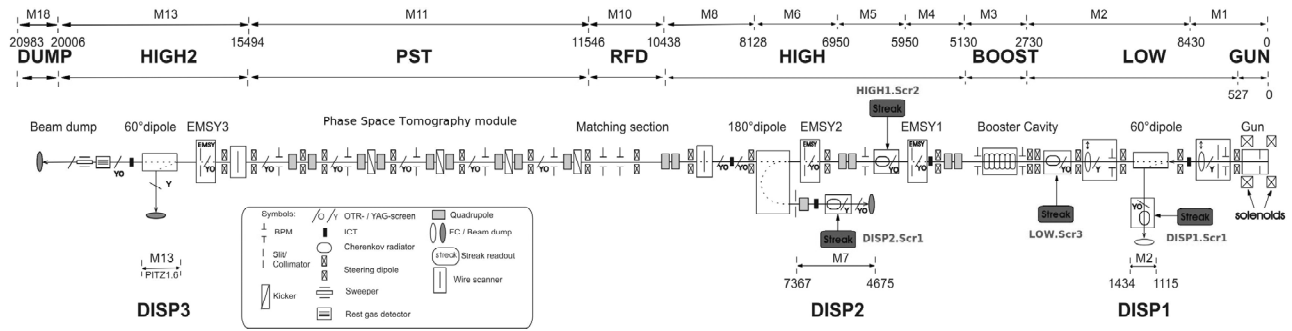

Figure 1: The current PITZ setup 2010 and 2011 [2].

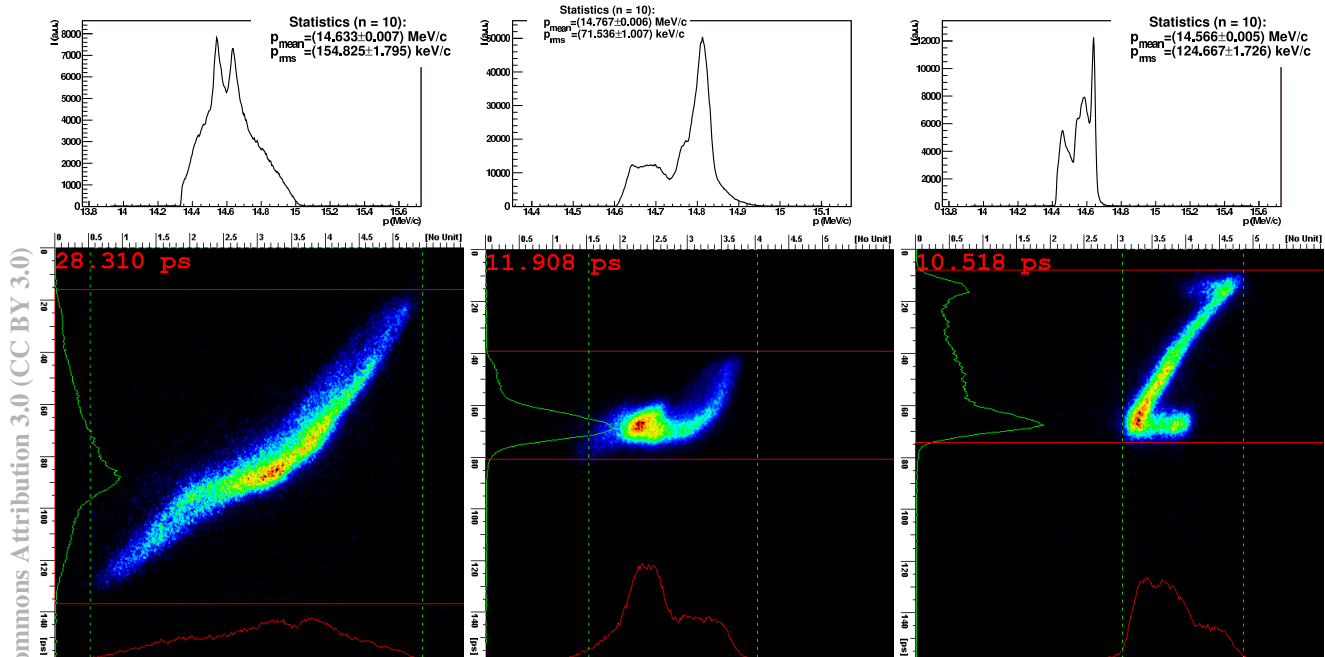

Figure 2: The streak camera image of the electron bunch (bottom) compared to the results from MAMA (top) for the maximum booster RF launch phase plus 10° (right), the maximum phase (middle) and maximum phase minus 10° (left). The temporal distribution of the streak image is flipped due to the momentum compaction factor of the deflecting dipole magnet.

(top), where MAMA is a tool for the Mean Momentum And the Momentum spread Analysis of electron beams at PITZ by using a dipole to deflect the electrons into a dispersive arm where the electron beam distributions can be measured using a YAG screen [5]. The temporal distribution of the streak image is flipped due to the momentum compaction factor of the deflecting dipole magnet.

The charge of the electron bunch was 220 pC. The laser pulse had FWHM ~ 23 ps, rise time ~ 2 ps and 3.32% modulation of laser flat-top (Fig. 3). The launch phase between RF and the laser is chosen such that the momentum gain in the gun and booster are maximum (MMM phase). The optimum launch phase for the gun was 101° and for the booster was 114°. The influence of the booster launch phase is also studied. Fig. 2 presents the streak image for the electron bunch compared to the momentum

measurements for different RF initial phase of the booster, at maximum momentum gain plus 10° (right) and minus 10° (left). The projection on the horizontal axis presents the momentum distribution and the projection on the vertical axis presents the temporal profile of the electron bunch. The projection of the streak image for the electron bunch agrees roughly in shape with the measurements obtained from MAMA.

Investigation of the Impact Temporal Laser Distribution

The effect of the temporal laser distribution was studied by introducing some modulation on the laser temporal profile (Fig. 4). The measurement of the longitudinal phase space distribution for additional different initial temporal laser distributions with strong modulations of 16.88% was

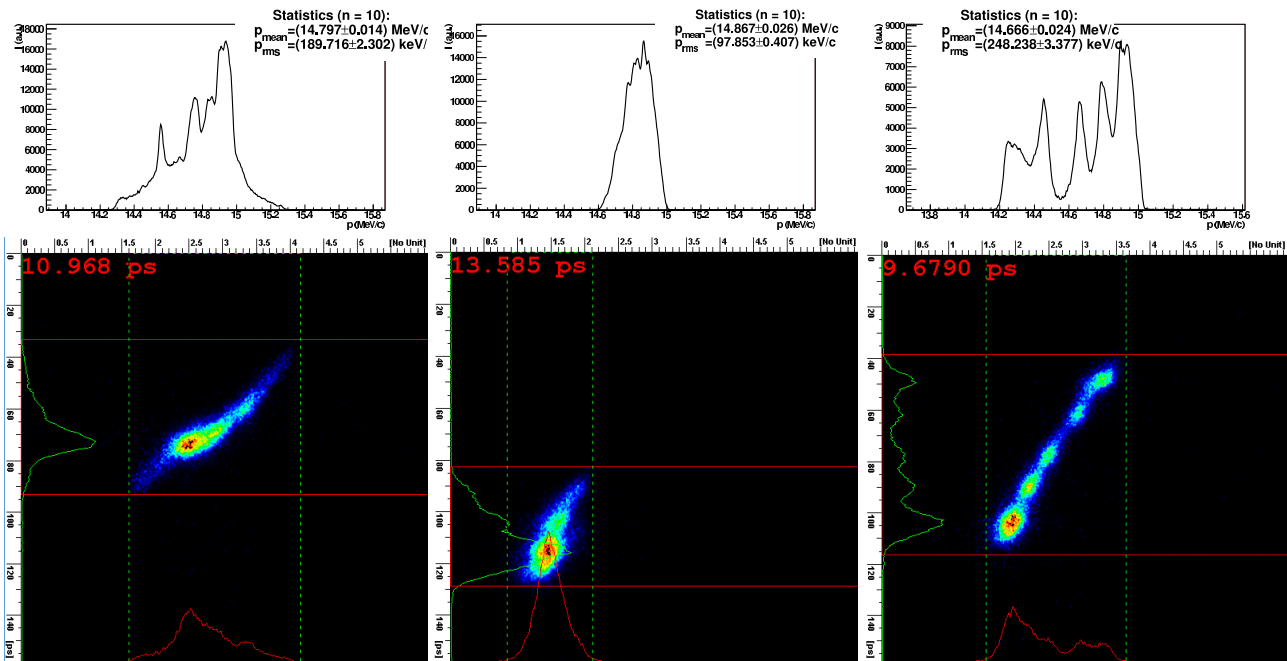

Figure 5: The streak camera image of the electron bunch (bottom) with introducing 16.88% modulation on the laser temporal profile, compared to the results from MAMA (top) for the maximum booster RF launch phase plus 10° (right), the maximum phase (middle) and maximum phase minus 10° (left).

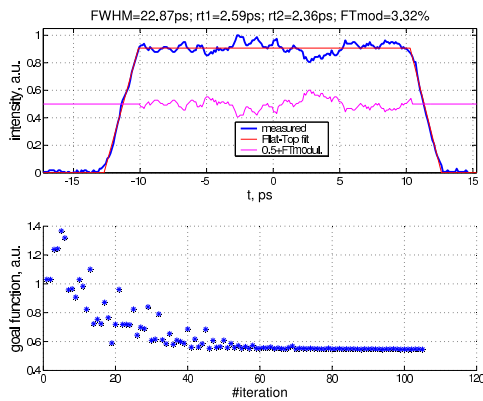

Figure 3: The temporal laser pulse profile with low modulation.

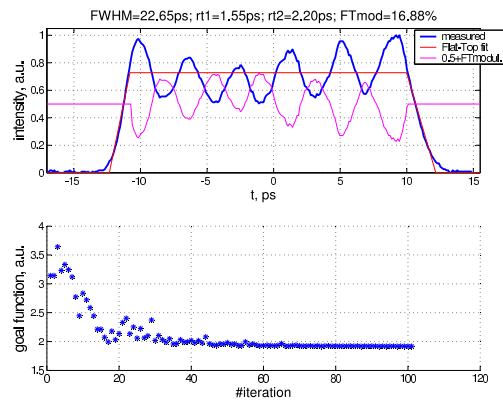

Figure 4: The temporal laser pulse profile with strong modulation.

done. The effect of the booster RF launch phase is also studied by performing the measurements at different launch phases. Fig. 5 presents the streak image for the electron bunch compared to the momentum measurements for different RF launch phases, at maximum momentum gain plus 10°, at maximum gain and at maximum gain minus 10°, respectively from right to left.

Difficulties and Future Improvements

The lens system used for the optical transmission and the spectrum width of the Cherenkov radiation causes a temporal dispersion of about 70 ps in the spectral range from 450

to 700 nm. To improve the resolution, the refractive elements should be exchanged by reflective elements that do not cause any chromatic effects. A replacement of the current lens system with a hybrid system based on reflective optics is expected to improve the temporal resolution. The signal intensity at the streak camera can be doubled without losing much temporal resolution. Tests for such hybrid system were done, realization will start soon [4].

Another difficulty is the radiation damage of the lenses. Due to the high level of X-ray radiation in the PITZ tunnel many lenses turn brown. To overcome the radiation damage, the replacement of the Achromat lenses, especially the lenses near the beamline, with more radiation hard quartz

lenses is planned.

THE TV-SYSTEM FOR DISP3

Introduction

The TV-system for DISP3 consists of two screen stations, DISP3.Scr1 and DISP3.Scr2. Each screen station has YAG and OTR screens combined with an optical read-out system consisting of mirrors, lenses, a resolution grid and a CCD camera. The TV- system reads-out an image of transverse distribution of the electron beam. This real-time image can be observed, analyzed and stored.

Design

The design of the TV-systems is done by defining the desired magnification M based on the size of the camera sensor, the size of the screen and the expected size of the beam image. M can be calculated by,

$$M = \frac{a'}{a} = \frac{h'}{h} \quad (1)$$

where a is the distance from screen to lens, a' is the distance from the lens to the camera, h is the screen size and h' is the camera sensor size. Then choosing a primary total length of the system L , which is the distance between screen and camera. From the optics laws,

$$L = a + a' \quad \text{and} \quad \frac{1}{f} = \frac{1}{a} + \frac{1}{a'} \quad (2)$$

where f is the focal length. The distances L , a and a' can be tuned to fit the required magnification M , keeping into account the available lenses and their focal length values since the producing companies do not produce lenses with any focal lengths but in a specific values. The diameters of all elements were chosen carefully to have minimum vignetting [7]. For alignment purpose a resolution grid is imaged onto the camera instead of the screen, where the distance between the screen and the camera is the same as the distance between the grid and the camera. The grid is illuminated from behind by a LED element. The switching between screen-camera and grid-camera branches is realized by a switching mirror. Prosilica GC-1350 and Prosilica TM 2030 GE cameras will be used to record the electron beam in DISP3.Scr1 and DISP3.Scr2, respectively.

The TV read-out of DISP3.Scr1 will have two magnifications:

- M1 = 0.076 for covering the whole screen.
- M2 = 0.264 for zooming on the beam only.

The total length of the TV optical system is 1211 mm.

The TV read-out of DISP3.Scr2 will have three magnifications:

- M1 = 0.5 for detailed view.
- M2 = 0.2 for zooming on the beam only.

- M3 = 0.138 for the whole screen.

The total length of the TV optical system is 1127 mm.

The problem of the depth-of-focus may occur in the TV read-out for the OTR screens since they are mounted at 45° rotation with respect to the electron beam propagation. To overcome this problem the "Scheimpflug method" is applied where the camera orientation can be adjusted towards the screen [7].

CONCLUSION

Longitudinal phase space measurements were done for different temporal cathode laser distribution, with small and strong modulations. The projections of the streak image were obtained and compared to the results of momentum measurements. Due to the radiation damage, many lenses, especial lenses near from the beam line turned brown. This affects strongly the streak measurements by significant intensity reduction.

The design of the TV-systems of the DISP3.Scr1 and DISP3.Scr2 was done, where they will have total optical length of 1211 mm and 1127 mm, respectively. Simulations and further calculations for improvement are still ongoing.

REFERENCES

- [1] Hamamatsu Interactive Java Tutorials - Streak Camera.
- [2] M. Mahgoub *et al.*, PITZ Collaboration Meeting 2010.
- [3] J. Roensch, Ph.D. thesis, University of Hamburg, 2009.
- [4] K. Rosbach *et al.*, Physics Acc-ph, arXiv:1101.3006v1, 2011.
- [5] D. Lipka, Momentum And Momentum spread Analysis (MAMA), PITZ Note 01-04.
- [6] S. Rimjaem *et al.*, Proceedings of DIPAC 2009.
- [7] J. Baehr, private communication.
- [8] F. Stephan *et al.*, Phys. Rev. Special Topics - Acc. and Beams 13 (2009) 020704.