

TWO BUNCHES WITH NS-SEPARATION WITH LCLS*

F.-J. Decker, S. Gilevich, Z. Huang, H. Loos, A. Marinelli, C.A. Stan, J.L. Turner, Z. van Hoover, S. Vetter, SLAC, Menlo Park, CA 94025, USA

Abstract

The Linac Coherent Light Source (LCLS) delivers typically one electron bunch. Two-bunch operation is also possible, and is used to generate XFEL (x-ray free electron laser) pulse pairs for pump / probe experiments. Pulse pairs from two electron bunches with up to 100 fs separation have been already produced using a split and delay in the laser which produces them on the gun cathode [1]. Here we present a method to produce two bunches with longer separations by the combining two laser systems. This method allows any time separation within the limits imposed by RF and safety systems. We achieved separations up to 35 ns (limited by a beam safety system), different beam energies, and also vertical separations of several beam diameters. The vertical separation enabled a successful user experiment, and although it led to large fluctuations in the X-ray pulse energy it also provided an efficient pulse intensity scan.

INTRODUCTION

An early two-bunch test in 2010 [2] with 8.4 ns bunch separation revealed the possibilities and constrains of multi-bunch operation. This two-bunch mode was initially envisioned to increase the hit rate in LCLS experiments as jets carrying samples could move sufficiently between bunches to expose a new part of the jet. Unfortunately, XFEL pulses also induce pressure waves and explosions, which damage the jets over distances longer than the jet translation between bunches, even for delays of a few

hundred ns [3]. Two-bunch operation with ns delays is nevertheless ideal for the investigation of these shock waves and explosions. The setup used in 2010 was upgraded and adjusted, as described in the next sections, for a user experiment [4] on XFEL explosions.

LASERS

Two mostly identical laser systems are used for the gun cathode at LCLS, and in standard operation a mirror selects one of the beams (Fig. 1). We added a 50/50 splitter (combiner) that can be interchanged with the mirror to either select one of the beams or combine them. The timing of each laser and the intensity of the combined beam could be controlled remotely. For the experiments reported here, we did not have remote and separate intensity control for the two lasers to adjust continuously the charge of the electron bunches, but we could set the ratio of the final FEL intensities to either 1:10 or 2.5:5 by moving the timing of the heater laser to coincide with the arrival of either the second or the first laser pulse. Only one bunch could be heated, since the timing delay stage is after the combination. This setup was sufficient for the experiments, and several improvements remain possible for the laser system concerning two-bunch operation, such as individual intensity control, laser heater for both bunches, and pointing control. Figure 2 shows the control layout used to run either one of the lasers for single bunches, or to combine them for two bunches.

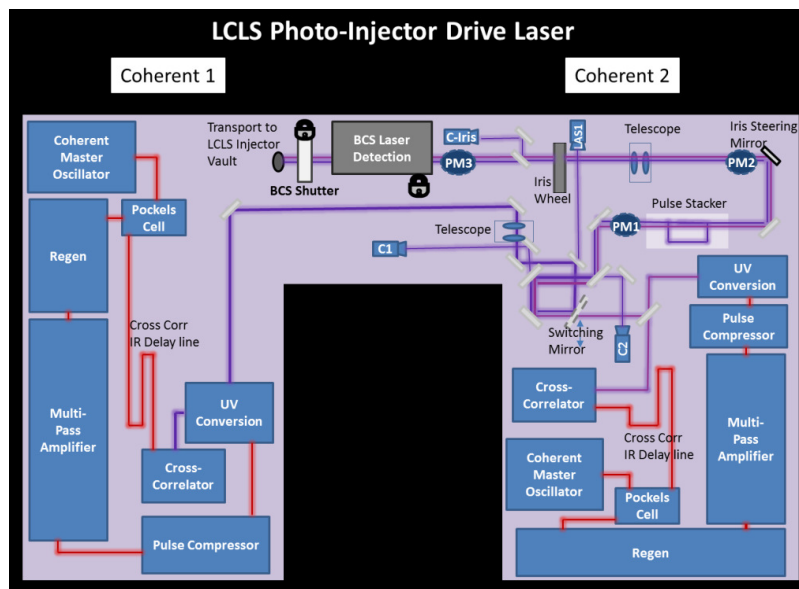

Figure 1: The laser system setup consists of two Coherent lasers, which can be selected with the switching mirror.

*Work supported by U.S. Department of Energy, Contract DE-AC02-76SF00515.

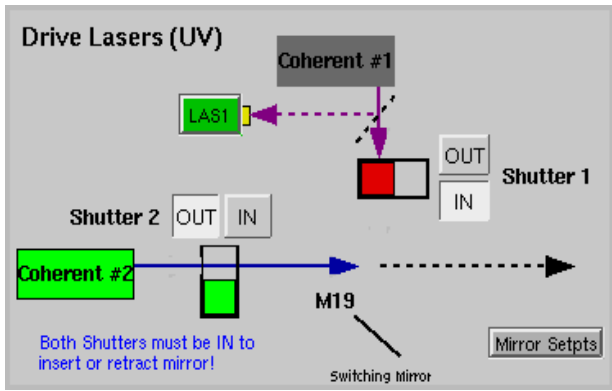

Figure 2: Controls layout to allow the different lasers or both with beam shutters.

TIMING AND BEAM CONTAINMENT

Typically the lasers are timed that they are contained inside a 40 ns BCS gate (Beam Containment System). Two timing scans were performed to detect the edges of the gate, one positive and the other negative. Figure 3 shows a timing scan with the Vitar1 oscillator in positive direction with steps of 360°. The energy change in BC1 is measured as different positions in x and 1 mm corresponds to about 1° or 1 ps timing change. Two things are visible, there is a three step periodicity of about 0.3° variations and after about 11,000° a timing step happens of nearly 1° when the trigger time changes. Since the two lasers can be adjusted separately in time (phase), it was used up to 2° to reduce the beam difference early in the accelerator. The beam stayed on for 38.2 ns (+20, -18 ns), which is close to the “40 ns” BCS gate (Fig. 4). The BCS gate of the lasers was the main constraint in the spring of 2015, but should be lifted for the fall running, so that only real accelerator RF will limit the bunch separation in time.

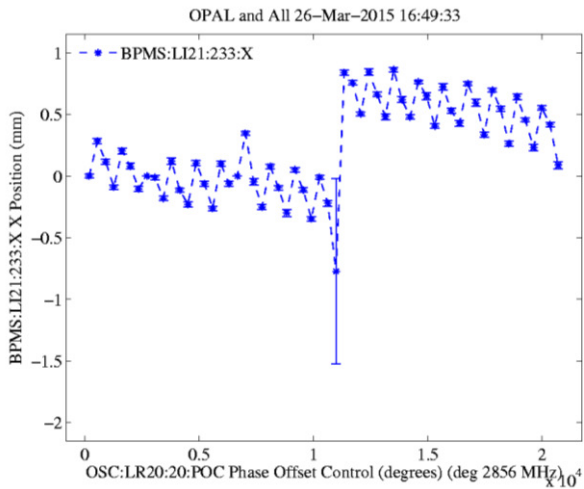

Figure 3: Timing scan of Vitar1 oscillator in RF degrees.

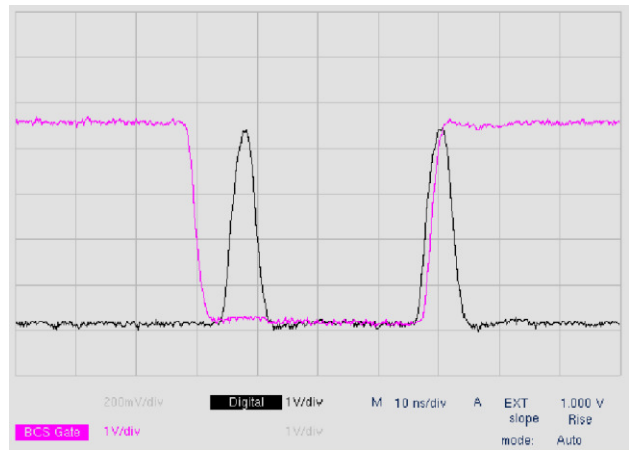

Figure 4: BCS gate (pink) and the two laser pulses close to the edges.

RF ISSUES

The RF pulses in the linac are long enough to allow up to about 400 ns separation of the two bunches, but since only one bunch was envisioned for LCLS, special setups are shorter. This includes the Gun and L1X RF pulses (Fig. 5 and 6).

Gun RF

Since the gun has a 1.6 cell structure it resembles a standing wave setup, where the plateau is achieved exponentially. To reduce the RF pulse energy that plateau is never reached since the pulse length is short. To achieve a flat pulse top the drive can be reduced suddenly to the necessary level for steady state condition.

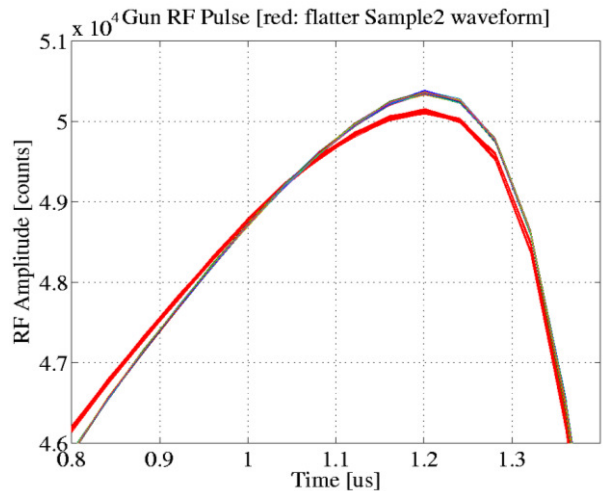

Figure 5: Gun RF pulse shows the filling time of the standing wave setup. By lowering suddenly the drive the equilibrium can be reached faster and a flattop achieved. Here it got flatter (red), but not yet flat.

LIX RF

Figure 6 shows the timing scan of the x-band linearizer klystron LIX. The RF pulse has to be lengthened to achieve more separation than 100 ns.

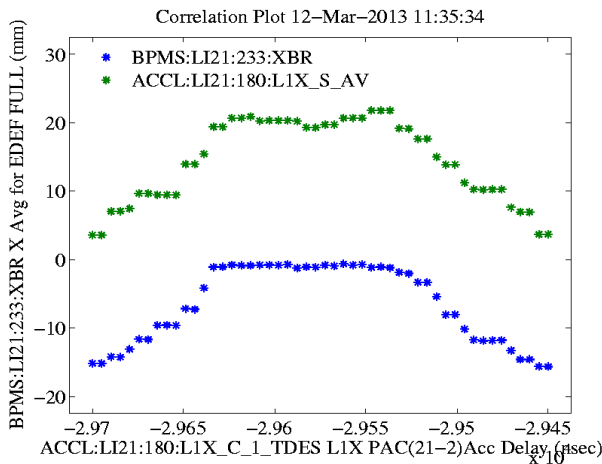

Figure 6: Timing scan for the LIX station, showing a 100 ns flat distribution.

BPM RESPONSE

The beam position monitor system (BPM) measures the position in x and y and also the beam intensity or beam charge. Since it down-samples to a certain frequency its intensity signal response is sensitive to the bunch separation of the two bunches. The signals of the two bunches get added like vectors and the response can be calculated using the sampling frequency of 140, 200, or 40 MHz of the different processors (Fig. 7 and 8).

By using the raw waveform of the BPMs and taking the expected bunch separation into account a bunch difference signal can be achieved (Fig. 9).

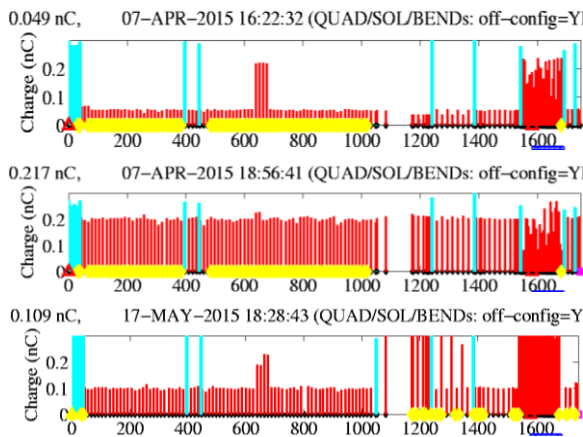

Figure 7: BPM response for roughly 18, 35 and 25 ns bunch separation along the accelerator distance z in meters. In cyan are toroid readings which are seeing $2 \cdot 0.15$ nC = 0.3 nC, while the first BPM “measures” 50 pC, 220 pC, 110 pC for the three time separations.

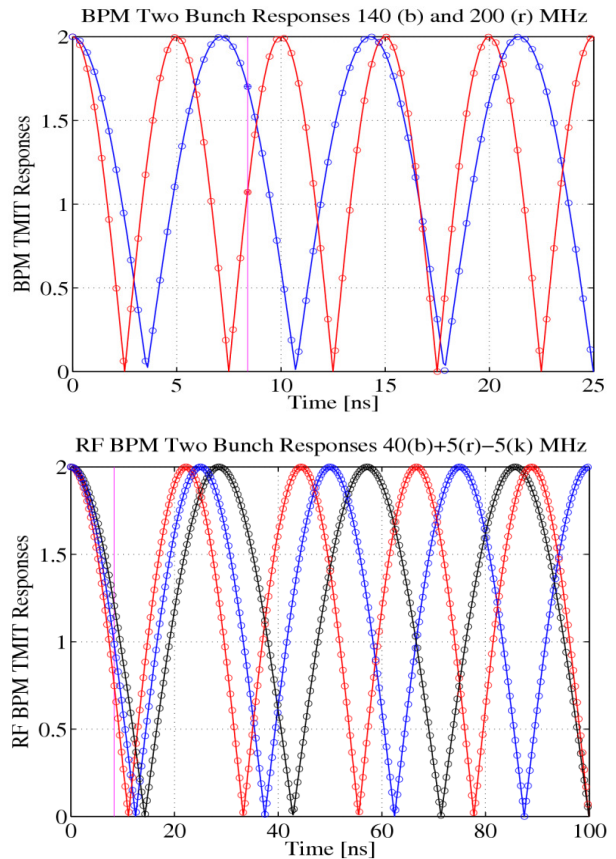

Figure 8: BPM intensity (TMIT) response for two strip line style BPM electronics (top) and RF cavity BPMs of the undulator (bottom). At certain delays no response is possible, but a little off and a signal with good positions is achieved.

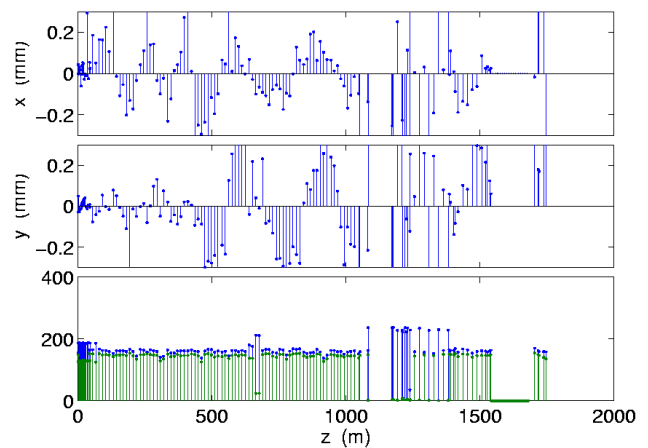

Figure 9: Difference orbit of two bunches with 25.2 ns (72 RF buckets) time separation. The intended kick in y with TCAV3 (at $z = 500$ m) is visible, but also an unintended x difference is visible which starts early in the linac.

ENERGY CONTROL

The beam energy of the two bunches can be controlled by adjusting the time of the RF pulse since the SLED pulse is not flat. This can be done in the region where the beam gets its correlated energy spread before BC2 (Fig. 10) and also afterwards to achieve different energies at the end for the photon experiment (Fig. 11).

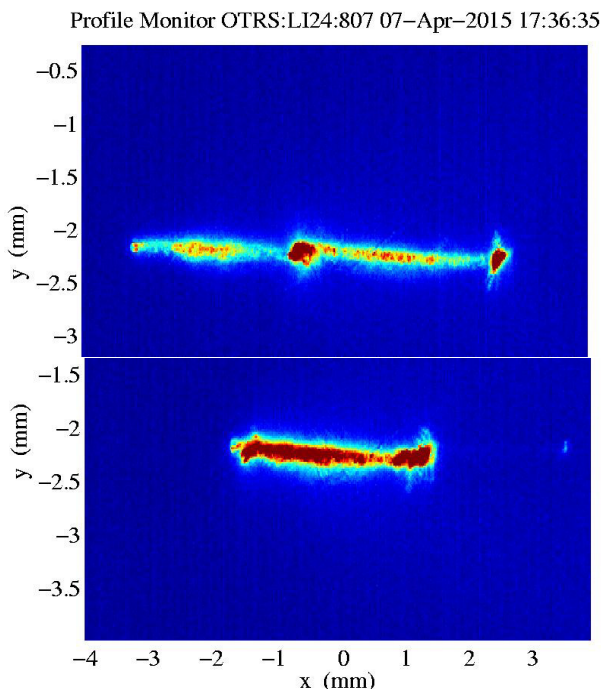

Figure 10: Energy distribution inside the BC2 chicane. Top: the two bunches have about 3 mm difference orbit, while at the bottom they overlap after adjusting the timing of the RF envelope.

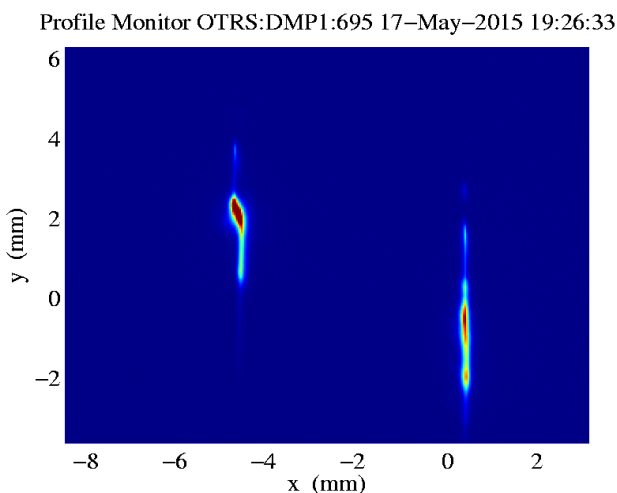

Figure 11: Beam distribution in energy (vertical) and time (horizontal) at the end on the dump screen. Left is the first bunch with higher energy than the second bunch to the right, which is also shorter. The big phase separation is not really understood yet.

Finally the photon beam energy can be measured with a spectrometer and the energy adjusted carefully so the first beam is above and the second beam is below the Cu K-edge of 8.98 keV (Fig. 12).

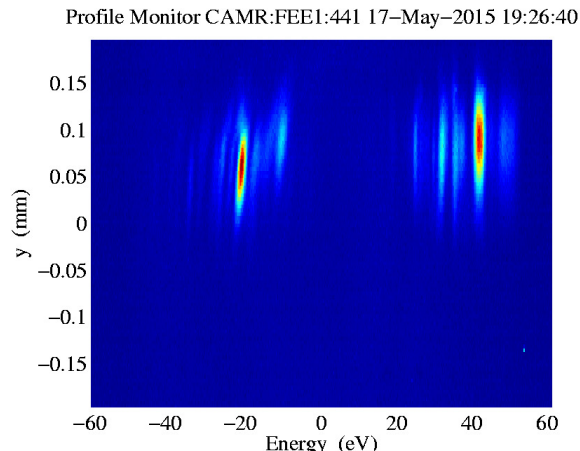

Figure 12: FEE (Front End Enclosure) spectrometer shows the two SASE photon pulses with about 60 eV energy separation (and 25 ns time separation).

TRANSVERSE CONTROL

The experiment asked also for a transverse separation in y of a few sigmas for the two bunches so the second bunch would hit the expanding sample. This was envisioned to be introduced with TCAV3 in Sector 25 (see Fig. 9), but a nasty instability of 3.6 Hz made the jitter three times worse, so it could not be used. But since there was also an x separation (Fig. 9) which had to be dealt with we decided to use the same approach for x and y . Since the two bunches have different energies an introduced dispersion will separate (or combine) them. Three corrector bumps after DL2 (Dog Leg 2) created enough dispersion so the two bunches were combined in x and separated in y (Fig. 13).

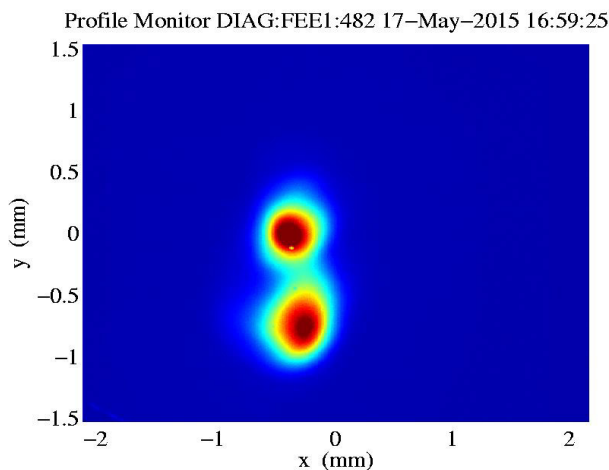

Figure 13: Two photon beams separated in y by a few spot sizes.

Copyright © 2015 CC-BY-3.0 and by the respective authors

PHOTON DIAGNOSTIC

The photon beam is measured somewhat destructively by screens (Fig. 12 and 13) although at hard x-rays most of the photons go through. This gives a measurement of the transverse size, which is x and y and beam intensity. With a bend crystal also the energy distribution is measured (Fig. 12). A gas detector measures the beam intensity non-destructively and since it has a time response we can also measure the relative intensity of two bunches when they are enough separation like 25 ns. Figure 14 shows the gas detector raw waveform of 300 pulses with a 1:10 and a 2.5:5 intensity ratio. Since the two bunches are separated in y any vertical beam jitter changes the trajectory in the undulator and the intensity varies widely (Fig. 15).

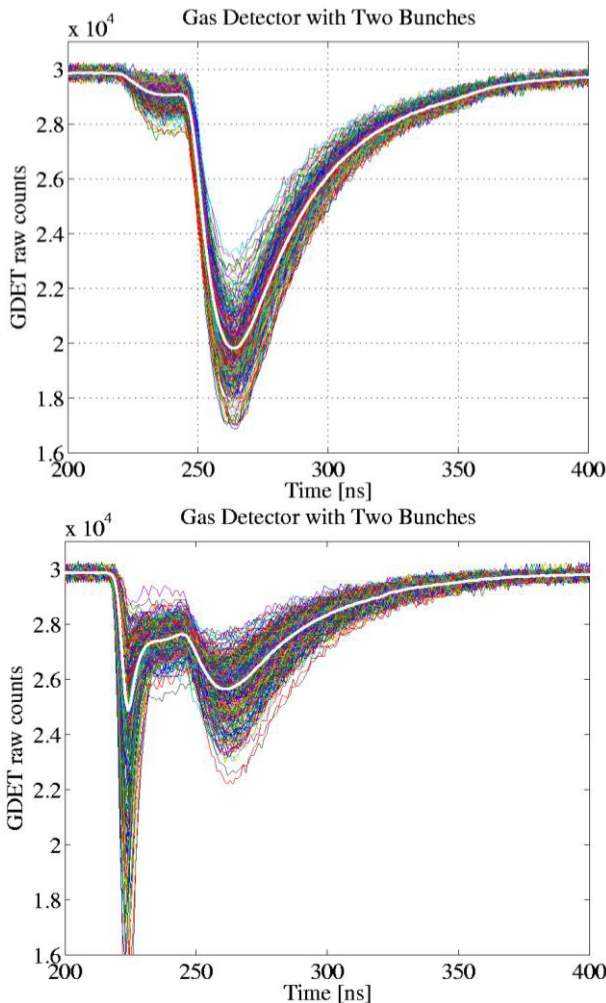

Figure 14: Gas detector raw waveforms and average (white) for different intensity ratios of the two bunches. The top shows an initial setup with 1:10 ratio for pump and probe, while the bottom shows a 2.5:5 ratio after the laser heater was timed for the first bunch. The spike in the front is an instrumental reaction to coherent synchrotron radiation. Therefore the integrated GDET signal typically uses the counts from 250 to 400 ns.

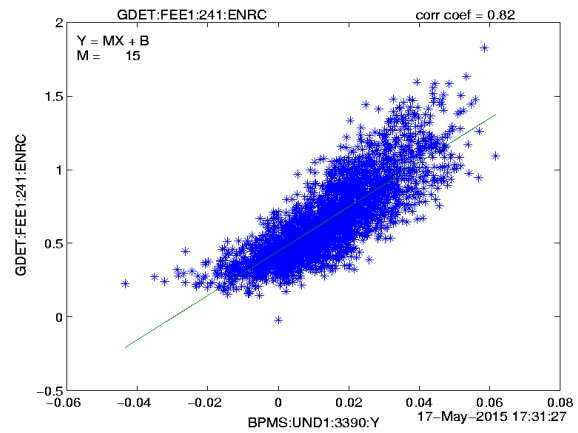

Figure 15: Integrated gas detector signal versus undulator position in y showing a strong correlation. Although the vertical jitter is not worse than typical running the different orbits of the two bunches away from the preferred center line makes it very jittery.

CONCLUSION

Two bunch operation with a few tens of ns time separation was studied and set up for an LCLS experiment which was successful in probing the effects of XFEL explosions in water droplets [4] (Fig 16). This setup with two bunches allows now time-resolved XFEL studies up to 40 ns, and soon beyond that. The micron-scale vertical separation of focused pulses at ns delays enables the study of propagating phenomena such as shock waves and other pressure-induced changes.

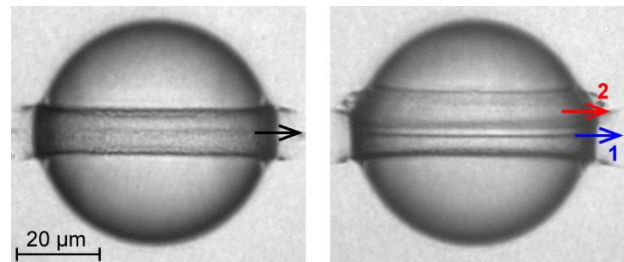

Figure 16: Visualizing the two-bunch mode at CXI (coherent x-ray imaging). Water droplets being hit by one (left) or two photon beams (right). The arrows indicate the XFEL beams.

REFERENCES

- [1] A. Marinelli et al., “High-Intensity Double-Pulse X-Ray Free-Electron Laser”, Nature Communications 6, 6 Mar 2015, Article number: 6369.
- [2] F.-J. Decker et al., “A Demonstration of Multi-Bunch Operation in the LCLS”, FEL 2010, Malmö, Sweden, WEPB33, p. 467.
- [3] C.A. Stan, S. Boutet, et al., in preparation.
- [4] C.A. Stan, private communication.