

# INITIAL COMMISSIONING OF ION BEAMS AT SPIRAL2

Patrick Bertrand, GANIL, Caen, France

## Abstract

The official reception of the SPIRAL2 accelerator building occurred in October 2014. In parallel, the installation of the accelerator components has started in June 2013. The first part of the beam commissioning, including the ECR sources, the LEBTs and the 88 MHz RFQ should start in December, with an injection in the Linac by mid-2015. This paper describes the status of the accelerator components and installation, and the philosophy retained to commission the light and heavy ion beams at various required final energies.

## INTRODUCTION

Officially approved in May 2005, the SPIRAL2 radioactive ion beam facility at GANIL (Caen-Normandy) has been launched in July 2005, with the participation of many French laboratories (CEA, CNRS) and international partners. In 2008, the decision has been taken to build the SPIRAL2 complex in two phases: *A first one* including the accelerator, the Neutron-based research area (NFS) and the Separator Spectrometer (S3), and *a second one* including the RIB production process and building, and the low energy RIB experimental hall called DESIR [1-3]. However, in October 2013 and due to budget restrictions, the RIB production part has been postponed, and DESIR included as a continuation of the first phase.

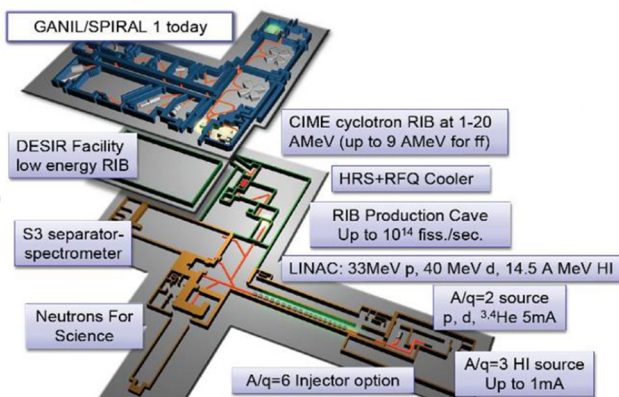

Figure 1: SPIRAL2 project layout, with experimental areas and connexion to the existing GANIL.

As recalled in Table 1, the SPIRAL2 accelerator must deal with a large variety of beams: protons, deuterons, heavy ions with  $A/q < 3$ , ( $A/q < 6$  in the future). A maximum beam power of 200kW is considered for deuterons in CW mode. We notice also that the heavy ion beam intensities can go up to 1 mA; however, some heavy ion beams like metallic ones can also have a very small intensity, which constitutes in itself a challenge, some diagnostics having to work with a huge response range!

Table 1: Beam Specifications

beam	P+	D+	ions	ions
A/Q	1	2	<3	<6 or 7
Max. I (mA)	5	5	1	1
Min. output E (MeV/A)	2	2	2	2
Max output E (MeV/A)	33	20	14.5	8
Max. beam power (kW)	165	200	44	48

In this paper, after giving updated information on the accelerator-NFS-S3 building and process installation, we will concentrate on our beam commissioning strategy.

## ACCELERATOR-NFS-S3 BUILDING

The construction permit of the accelerator-NFS-S3 building was obtained in October 2010. After a difficult excavation work and geotechnical/geologic studies, the first concrete started in September 2011. The building itself was officially received last October 2014 (Figure 2), and the utilities will be officially approved very soon.

During the construction, several inspections were made by the French Safety Authorities, in order to check the conformity of the building with respect to the requirements like confinement barriers, protection against earthquakes, etc...



Figure 2: Completion of the accelerator building (October 2014). The beam axis is 9.5 meters underground.

## STATUS OF THE ACCELERATOR

The building construction process has been organised in such a way, that it was possible to install progressively the process inside the building, starting by mid 2013 with the low energy beam lines and their power supply and utilities, all this in parallel with other parts of the building construction (HEBT for example). This strategy allowed us to gain about one year, but the coactivity between building and process teams, and the planning optimization appeared to be not so easy to manage, one difficulty being

the cleanliness needed for many Linac deliveries.

At present, the accelerator status of installation is the following:

The 18GHz ECR heavy ion source called Phoenix-V2 and updated to host metallic ovens, is now installed on site, together with its transport line called LEBT1.

The 2.45GHz ECR light ion source is also installed together with its transport line called LEBT2, and the main part of the merging section LEBTC line.

The 88MHz 4-vane RFQ is now assembled and aligned in the tunnel, with good vacuum tests. The bead pull is well underway, and the RFQ conditioning should occur by beginning of 2015.

The first part of the MEBT is ready to be installed and to be connected to the D-plate.

Concerning the Linac, all the cavities are qualified on vertical cryostats and tested with success. Eight low-beta cryomodules are assembled and tested, and the 4 remaining ones will be qualified and delivered at GANIL/SPIRAL2 by March 2015. Five high-beta cryomodules are qualified and ready to be installed in the tunnel, while the 2 remaining ones will be ready next December [4]. All the couplers are processed and conditioned [5], and all the warm section packages are ready to be installed. The installation of the Linac itself should start by November, waiting for the complete cleanliness of the tunnel.

All the dipoles, quadrupoles and steerers of the HEBT [6] are received and measured, and the profilers are ready to be installed. The mechanical HEBT supports are positioned, and the aluminium vacuum pipes and stainless steel diagnostic boxes are under fabrication.

All the RF amplifiers are received and tested at GANIL with a specific RF test bench, their complete installation being programmed by end of November. The cryogenic system is under final installation.

## BEAM COMMISSIONING STRATEGY AND FIRST RESULTS OBTAINED

Several years ago, we took the decision to operate the SPIRAL2 beam commissioning in 4 phases:

*First of all*, we decided to pre-install the ECR sources and low energy transport lines in two French laboratories, in order to test them *with beam* before the SPIRAL2 building availability: these successful tests were achieved by end 2012, before transportation to GANIL.

The *second phase* of beam tests concerns the injector: they will start next December at SPIRAL2/GANIL site, and will last six months, with the RFQ connected to the D-plate. We will basically reproduce the results obtained without RFQ, operate the tuning and conditioning of the RFQ, and measure the beam characteristics at RFQ exit, using the D-plate.

After dismantling of the D-plate, the *third phase* will concern the tuning of the beam with the complete MEBT, the beam tests of its fast chopper, the Linac acceleration,

and the tuning of the HEBT going to the Beam Dump.

The *fourth phase* will be the “day-1” experiment, with beam delivery for NFS physics studies by end 2015, and S3 in 2016.

### Beam pre-commissioning at LPSC Grenoble

Dedicated to heavy ions, the 18GHz Phoenix-V2 ECR source and its achromatic analysis beam line LBET1 have been installed at LPSC laboratory (Grenoble) during about 2 years, until June 2012 (Figure 3). The ECR source and its environment were updated these last years, to host metallic ovens developed at GANIL, and sustain 60 kV (See also [7, 8] for more details).

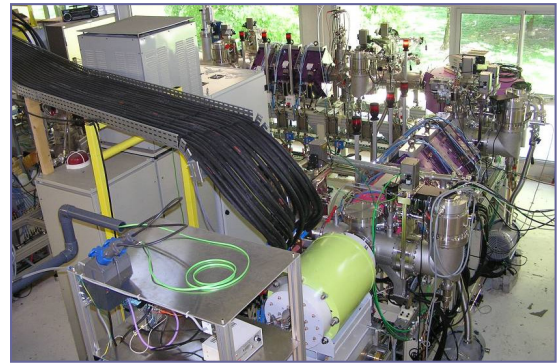

Figure 3: View of ECR source and Spiral2 LEBT1 when installed at LPSC for beam tests until mid 2012.

- Using automated optimization algorithms developed from the TRACEWIN code, we obtained 30% more than 1mA of  $^{16}\text{O}^{6+}$  (goal for SPIRAL2), and 70 $\mu\text{A}$  of  $^{40}\text{Ar}^{12+}$ , with a good transmission (95%). Around 2mA of  $^4\text{He}^{2+}$  were also achieved, which is of interest to mimic the deuteron beam and learn how to tune the Linac.
- As expected, we measured transverse emittances around 0.25  $\pi\cdot\text{mm}\cdot\text{mrad}\cdot\text{norm}\cdot\text{rms}$ , with an efficient action of the hexapole corrector associated to the analysis bending magnet (Figure 4). Very similar transverse beam profiles in both pulsed and CW source mode were also obtained.

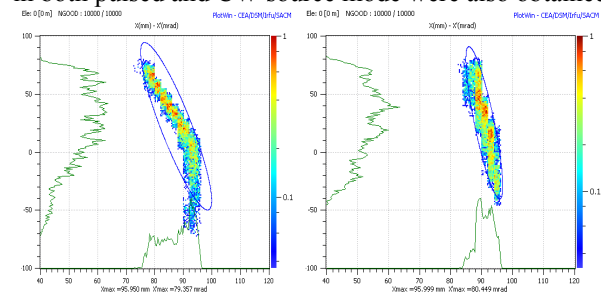

Figure 4: Horizontal dipole aberrations (left) optimized (right) tuning the hexapole ( $^{16}\text{O}^{6+}$ , 0.8mA beam)

- The separation power of the LEBT1 line is found better than specified. (>100), which is a good sign for future Linac pure beam acceleration (Figure 5).
  - We also obtained more than 20 $\mu\text{A}$  of  $^{58}\text{Ni}^{19+}$  (Figure 6), and 48 $\mu\text{A}$  of  $^{48}\text{Ca}^{16+}$ , which is very promising [9]
- In 2013, and thanks to a European contract, the LPSC



laboratory started a development of the new economical Phoenix-V3 ECR source, with a bigger plasma chamber (1.4 liter instead of 0.6), in order to increase the ion rate production, and accept new generation metallic ovens (20 mm diameter). First beams with Phoenix-V3 are expected in January 2015, using the LPSC Test bench [10].

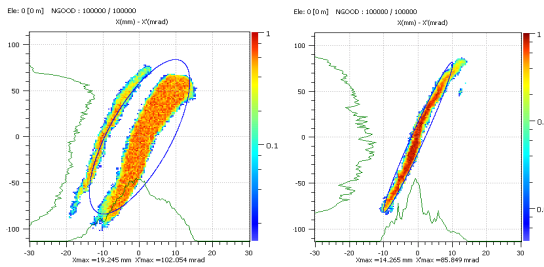

Figure 5: Beam separation of beams ( $^{16}\text{O}^{3+}$  and  $^{132}\text{Xe}^{25+}$ ) with 20mm (left) and 5mm (right) slit aperture.

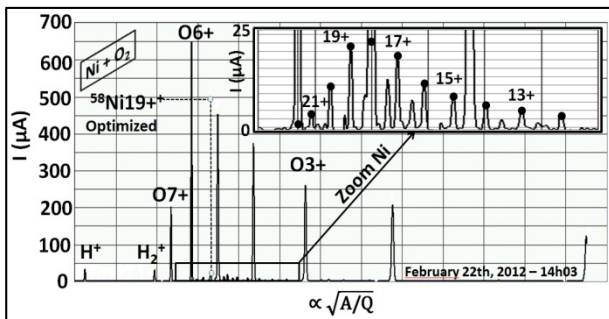

Figure 6: Spectrum optimized for  $^{58}\text{Ni}^{19+}$  (~20  $\mu\text{A}$ ), using the Large Capacity High Temperature Oven from GANIL

*Beam pre-commissioning at IRFU/Saclay*

Important results were also obtained in 2010-2012 at IRFU/Saclay, where the deuteron/proton ECR source, the transport lines LEBT2 (achromatic analysis section) and LEBC (merging transport and matching line to the RFQ) have been installed in several successive steps (Figure 7).

These results were obtained by using intensively the TRACEWIN code for the beam tuning, and by applying the “virtual accelerator concept” explained in [11]. Here are the main results obtained (see also [12]):

- First of all, the 2.45GHz permanent magnet ECR source confirmed its capability to produce a very stable and reproducible 6.7mA 40kV deuteron in CW or pulsed beam mode (and also down to 50 $\mu\text{A}$  in CW), with an emittance between 0.1 and 0.22  $\pi\text{.mm.mrad.norm.rms}$ , depending upon the tuning of the slits and the vacuum level.
- We also verified that the set of movable LEBT slits were efficient to clean the generated halo optimally, and that we could chose the vacuum level in order to optimize the space charge compensation parameter.
- The slow chopper, developed by INFN Catania, has been tested on line and gave excellent results [13]: Transition times below 30 ns were confirmed as well as the duty cycle range from 0.1% to 99.99%. The device can operate up to 10 kV, up to 1 kHz. The slow chopper will be used intensively to manage the beam duty cycle.
- Automatic beam alignment and optical procedures

showed very efficient behaviors, with transverse emittance portraits and perfect RFQ matching parameters achievements: By installing at the *exact* RFQ injection point the very nice emittance-meter developed by IPHC/Strasbourg, we could measure the emittances (Figure 8) and by generating a set of  $10^6$  particle reproducing them, we could check with the TOUTATIS code that the real beam should be correctly bunched and accelerated through our RFQ model (Figure 9).

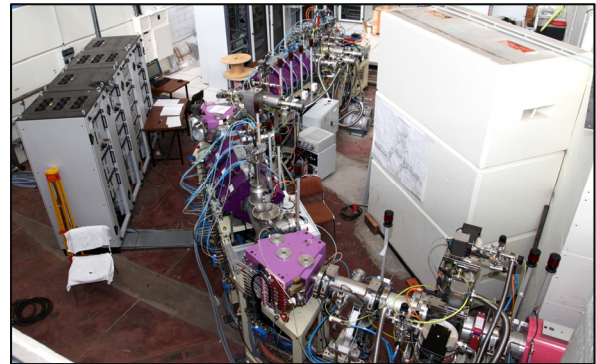

Figure 7: View of the ECR source, and LEBT2+LEBTC installed at IRFU (Saclay) for beam tests until end 2012.

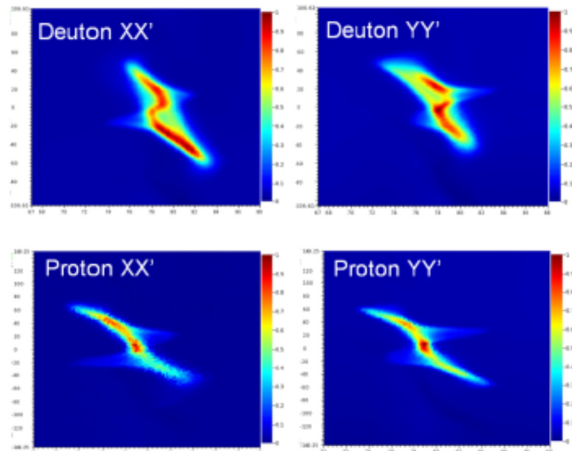

Figure 8: Deuteron and proton transverse emittances at RFQ injection point. (5mA in CW mode)

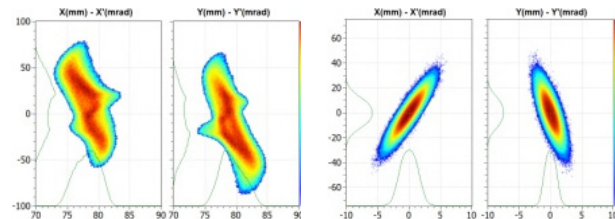

Figure 9:  $\text{D}^+$  measured emittances as input for RFQ TOUTATIS acceleration, and output emittances obtained.

*Remark:* before going to the 2<sup>nd</sup> beam test phase, we mention that thanks to our partnership with existing accelerators (SARAF, INFN-HH, GANIL...), we were also able to test various components like diagnostics in presence of existing beams, and to have some irradiation tests on samples to check their resistance to radiations and to validate the activation codes.

### Beam Commissioning of Injector at SPIRAL2

As already mentioned, the two ECR sources and their associated LEBTs are now installed in the SPIRAL2 building, and we should reproduce quite easily by December 2014 the results obtained at Grenoble and Saclay respectively. The 88 MHz 4-vane RFQ has been assembled one month ago (Figure 10), with the bead pull tuning to be started. After the RFQ RF conditioning, we will enter into the complete injector beam commissioning, using the first MEBT meter, and the D-plate (Figure 11) connected after the 1<sup>st</sup> rebuncher), in the following way:



Figure 10: SPIRAL2 RFQ assembled in September 2014.

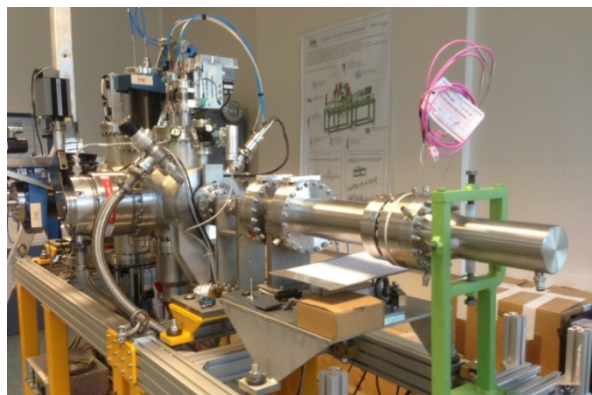

Figure 11: Assembly tests of diagnostics on D-plate

First of all, the D-plate is equipped with a set of the diagnostics: BPMs, ToF, FCT, DCCT/ACCT, harps, H-V emittance-meters... This will allow us to characterize the RFQ behaviour in terms of transmission, transverse emittances, beam profiles, energy and energy dispersion. By changing step by step the amplitude of the 1<sup>st</sup> MEBT rebuncher, and measuring the longitudinal beam length towards the end of the D-plate, we will also deduce the longitudinal emittance using the 3 gradients method.

All these measurements will be performed for the following beams successively:

- Protons ( $A/Q=1$ ) 150 $\mu$ A peak, 200 $\mu$ s pulsed@5Hz (0.1% duty cycle), and then increase the peak current from 150 $\mu$ A to 5mA, with duty cycle from 0.1% to 100%
- Helium  $^4\text{He}^{2+}$  ( $A/Q=2$ ) 150 $\mu$ A peak, 500 $\mu$ s pulsed @2Hz (0.1% duty cycle), and then increase the peak

current from 150 $\mu$ A to 2mA, with duty cycle from 0.1% to 100%

- Oxygen  $^{18}\text{O}^{6+}$  Pencil beam 150 $\mu$ A peak, 500 $\mu$ s pulsed @2Hz (0.1% duty cycle), and then increase the peak current from 150 $\mu$ A to 1mA, with duty cycle from 0.1% to 100%
- If enough time, tests with Argon, Carbon, Xenon
- Nickel  $^{58}\text{Ni}^{19+}$  up to 20 $\mu$ A, 100% duty cycle.

The optimisation will be done by playing with the beam matching at RFQ entrance using the double solenoid, the LEBT vacuum level and the RF compensation ring, the beam input energy and alignment and the RFQ voltage. We can notice that the set of 3 horizontal-vertical slits and associated profilers installed before the RFQ entrance allow us to change the emittance homothetically.

*Remark 1:* During this “injection phase”, Helium beam will be used instead of the Deuteron one, because Deuterons are not allowed before having the complete authorisation given later by the French Safety authorities.

*Remark 2:* During this intermediate beam commissioning, the installation of the Superconducting Linac and of the HEBT lines and beam dump will go on in parallel, and the command/control will be achieved, with the needed high level applications.

### Full Beam Commissioning Phase with the Linac

Once the D-plate withdrawn and the complete MEBT installed and connected to the Linac, and thanks to the knowledge acquired, to the efficiency of TRACEWIN code and to our 3D electromagnetic maps, we will pre-tune the complete 0.75MeV/u MEBT, for each beam of interest. Then we will create the SC Linac beam periodic channel step by step in the following way:

- Adjust all the quadrupoles of the linac HEBT to the Beam Dump according to the RFQ-MEBT energy,
- Tune the first cavity (amplitude & phase) using BPMs by Time of Flight measurement,
- Re-adjust all linac and HEBTs quadrupoles,
- Tune the second RF cavity,
- Operate the same way for the other 25 cavities...

The Linac tuning will be ensured by means of Beam Position Monitors (BPM) buried into the first quadrupole of each of the 19 Linac warm sections, while the beam extension monitors (BEM) installed in the 5 first warm sections [14] will allow us to tune the 3 MEBT rebunchers, in order to match the beam to the linac longitudinally.

The survey of the beam intensity and the energy will be ensured by several ACCT/DCCT devices, and a ToF system installed at the exit of the Linac ([15-17]), in the frame of the Machine Protection System [18].

The BLM scintillator detectors, developed by IFIN-HH/Bucarest and disposed around the Linac and HEBT lines, will deliver a “beam stop” signal in case of



excessive beam losses. Loss rings disposed along the HEBT vacuum pipes will also provide untimely steering information and similar beam stops signals, in order to protect the machine against beam thermal damage, together with beam energy and transmission.

### *Beam Commissioning towards NFS*

The fourth commissioning phase will consist in conducting the beam to NFS experimental hall. In the (probable) case of a first experiment based on Neutron Time of Flight, we will tune the 5mA Deuteron beam at the source, and use extensively the Fast chopper (also called "Single Bunch Selector") located along the MEBT: This device must reduce by 100 to 10000 the bunch rate in order to avoid neutron bunch overlapping effects for physics. It is based on the superposition of a steerer magnet and 2 high impedance meander electrodes driven with high voltage pulses of opposite sign. A vacuum chamber prototype equipped with 100Ω meanders and feed-through have been constructed in collaboration with INFN-LNS and successfully tested in Catania [19]. The final device should be operational in a few months.

### *One Way to Gain Time during Future Operation*

As already mentioned we will accelerate a variety of beams with various ratios  $q/m$ , which could generate much time for each tuning in operation. One way to limit it is to make use of an important theorem valid even in the relativistic case:

Suppose that we know the set of parameters already tuned and archived for a beam with a given  $q/m$ , and that we want now to accelerate a new beam with another  $\hat{q}/\hat{m}$ , and let define their relative difference:

$$\varepsilon = \frac{\hat{q}/\hat{m} - q/m}{q/m}$$

Then by multiplying all the voltages and magnetic values of the machine by the factor  $1/(1+\varepsilon)$ , we can accelerate the beam without major difficulty (with adjustment of last cavities and HEBT fields depending on the final energy needed...). In particular *all* the phases remain unchanged!

## CONCLUSION

The beam pre-commissioning performed at IRFU/Saclay and LPSC/Grenoble was essential to validate our low energy design and simulations, and to operate many technical tests with the EPICS philosophy and our Command/Control. We enter now in the complete beam commissioning on SPIRAL2 site, which constitutes a great motivation and for all our partners and for us.

## AKNOWLEDGEMENT

I would thank E. Petit, F. Robin, D. Uriot, J.L. Biarrotte and all the colleagues who helped me to collect the information presented in this document.

## REFERENCES

- [1] The scientific objectives of the SPIRAL2 project. [http://pro.ganil-spiral2.eu/spiral2/what-is-spiral2/physics-case/at\\_download/file](http://pro.ganil-spiral2.eu/spiral2/what-is-spiral2/physics-case/at_download/file)
- [2] E. Petit, "progress of the SPIRAL2 project", IPAC 2011, San Sebastian, Spain, September 2011.
- [3] P. Bertrand, R. Ferdinand, "SPIRAL2 accelerator construction progress", LINAC 2012, Tel-Aviv, Israel, September 2012.
- [4] P.E. Bernaudin, "SPIRAL2 cryomodule production results and analysis", LINAC 2014, Geneva, Switzerland, September 2014.
- [5] Y. Gomez et al., "Last SPIRAL2 couplers preparation and RF conditioning", SRF 2013, Paris, France, September 2013.
- [6] L. Perrot et al., "HEBT lines for SPIRAL2 facility: what to do with the accelerated beams", HB2010, Morschbach, Switzerland, October 2010.
- [7] J.L. Biarrotte et al., "First beams produced by the SPIRAL2 injectors", Linac 2010, Tsukuba, Japan.
- [8] C. Peaucelle et al., "First A/Q=3 Beams of Phoenix V2 on the heavy low energy beam transport line of SPIRAL2", ECRIS2010, Grenoble, France, Sept.2010.
- [9] C. Barué et al. "Metallic beam developments for the SPIRAL2 project", ICIS 2013, Chiba, Japan, September 2013.
- [10] Th. Thuiller et al, "Recent results of Phoenix V2 and new prospects with Phoenix V3", ECRIS2012, Sydney, Australia, Septemeb 2012.
- [11] D. Uriot, "The virtual accelerator concept", EUROCARD2/MAX Accelerators for the driven system workshop", CERN, March 2014.
- [12] D. Uriot, O. Tuske et al, J.L. Biarrotte, "Commissioning of the SPIRAL2 Deuteron injector", IPAC2013, Shanghai, China, May 2013.
- [13] A. Caruso et al., "The LEBT chopper for the SPIRAL2 project", IPAC2011, San Sebastian, Spain, September 2011.
- [14] R. Rovenko, "SPIRAL2 Bunch Extension Monitor", LINAC 2014, Geneva, Switzerland, September 2014.
- [15] W. Le coz et al., "Progress on the beam energy monitor for the SPIRAL2 accelerator", IBIC2014, Monterey, USA, Sept 2014.
- [16] Ch. Jamet et al. "Beam intensity and energy control on the SPIRAL2 facility", LINAC 2012, Tel-Aviv, Israel, September 2012.
- [17] Ch. Jamet et al, "Failure mode and effect analysis of the beam intensity control for the SPIRAL2 accelerator", IBIC2014, Monterey, USA, Sept. 2014.
- [18] M-H. Moscatello, "Machine protection system for the SPIRAL2 facility", IPAC2012, New Orleans, USA, May 2012.
- [19] M. Di Giacomo, A. Caruso et al., "Measurement of the first prototype of the SPIRAL2 SBS selector". IPAC2012, New Orleans, Mai 2012.