

BEAM DIAGNOSTICS SYSTEM FOR A PHOTO-NEUTRON SOURCE DRIVEN BY 15MeV ELECTRON LINAC*

Y.B. Yan, Y.B. Leng#, L.Y. Yu, R.X. Yuan, J. Chen, W.M. Zhou, Z.C. Chen
SINAP, Shanghai, P.R. China

Abstract

A photo-neutron source driven by 15MeV electron Linac is under construction at Shanghai Institute of Applied Physics (SINAP, CAS). Several kinds of beam monitors (BPM, Profile and ICT) have been installed. The stripline beam position monitor with eight electrodes was designed, also for energy spread measurement. Due to the multi-bunch operation mode, the customized RF front end was adopted, which down-convert the signal from 2856MHz to 500MHz and then bring it to Libera Single Pass E. The beam profile monitor was based on the integrated step-servo motor and GigE Vision camera. For the beam charge measurement we used the ICT from Bergoz and oscilloscope from Agilent. The details of the beam diagnostics system for the 15MeV electron Linac will be reported in this paper.

OVERVIEW

A photo-neutron source driven by 15MeV electron Linac is under construction at Shanghai Institute of Applied Physics, Chinese Academy of Sciences. It will be used for the neutron-related scientific experiment. Table 1 shows the main parameters of the electron Linac.

Table 1: Main Parameters of the Electron Linac

Parameter	Value
Energy (MeV)	15
Energy Spread (rms)	< 0.1%
Bunch Length of Macro Pulse (us)	~ 3
Average Current (mA)	~ 0.5
Beam Size (mm)	40 ~ 50 (Gauss)

The goal of the beam diagnostics system is to measure various kinds of the beam parameters, such as position, transverse profile, charge and energy spread/emittance. It is used not only for the accelerator commissioning or daily operation, but also for the further optimization of machine status. The whole system should be of high reliability and stability.

According to the physical design, the specification of the various diagnostics systems is listed in Table 2. The stripline beam position monitor with eight electrodes was designed, also for energy spread measurement. The beam profile monitor was based on the integrated step-servo

motor and GigE Vision camera. For the beam charge measurement the integration current transformer (ICT) from Bergoz was adopted.

Table 2: Beam Diagnostics Specification

System	Parameter	Value
Position	Resolution (um)	< 50
	Repetition Frequency (Hz)	> 50
Profile	Resolution (um)	< 100
	Measuring Range (mm ²)	30 × 30
	Repeat Positioning Accuracy (mm)	< 0.1
Charge	Resolution (%)	< 2
	Beam Charge Range (nC)	10 ~ 2400

BEAM POSITION MEASUREMENT

The system can be divided into three parts, which are the beam position monitor, the RF front end and the signal processing electronics.

Beam Position Monitor

The stripline type monitor with eight electrodes was designed and manufactured. It is used not only for beam position, but also for energy spread measurement. The structure of the monitor is shown in Fig. 1.

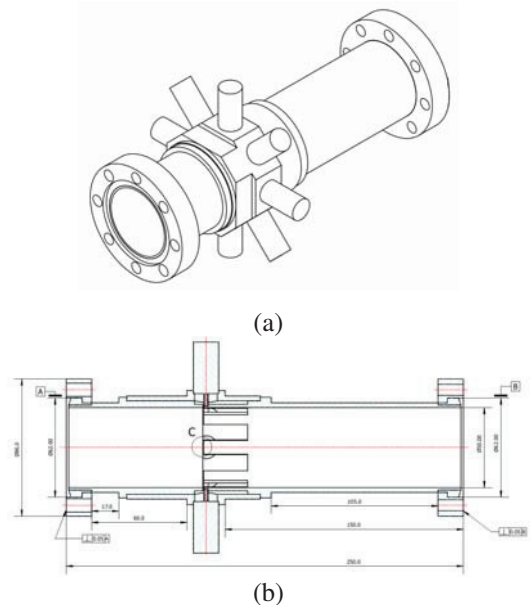

Figure 1: The structure of eight-electrodes monitor.

* Work supported by Chinese Academy of Science and National Natural Science Foundation of China (No. 11105211)
lengyongbin@sinap.ac.cn

Due to the multi-bunch operation mode, the working frequency is chosen to 2856MHz. For the 50mm section (the diameter of vacuum pipes), the length, thickness and angle of the electrodes are 26.2mm, 2mm and 20deg. The signals are lead out through 50Ω load. All the parameters have been simulated in Mafia.

Using the eight-electrodes monitor, more information about the electron beam can be obtained, such as the energy spread, the shape-factor of beam profile, etc. We have carried out the principle analysis. The related experiments will be performed soon.

RF Front End

The RF front-end electronics is used to down-convert the signal from the eight-electrodes monitor. It consists of band-pass filters (BPF), attenuators, mixers, low-noise amplifiers (LNA), etc. The schematic diagram is shown in Fig. 2.

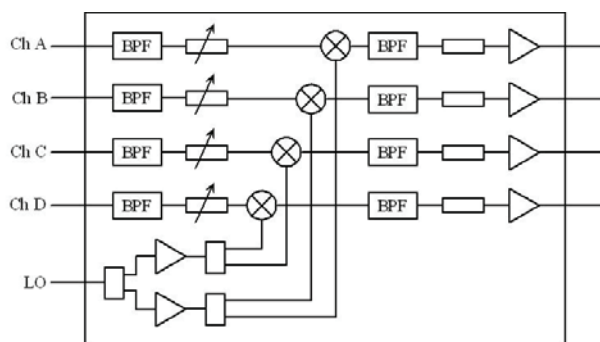

Figure 2: The schematic diagram of RF front-end.

The central frequency of the first BPF is 2856MHz, the passband is ~ 150 MHz. For the second, they are 500MHz and ~ 100 MHz. The R&K MX360-0S is used for mixing the local oscillator (LO) signal to 500MHz. The LO signal is obtained from the accelerator microwave system. One unit contains four channels, so two units are needed for one eight-electrodes monitor.

Signal Processing Electronics

The new Libera Single Pass E [1] from Instrumentation Technologies is used for the following-up beam signal processing, as shown in Fig. 3. It features accurate electron beam position measurements at various data rates with low crosstalk between channels.



Figure 3: Libera Single Pass E.

The signals from the RF front-end electronics are processed in the signal processing chains, which are composed of analog signal processing, digitalization on fast ADCs and digital signal processing. Libera Single Pass E can contain up to four beam position processor modules. In our case, one unit chassis with four modules installed corresponds to two BPM units.

BEAM PROFILE MEASUREMENT

The beam profile monitor is used to measure the beam transverse parameter (shape, size or relative position). The detector with multi-screens was adopt. Due to the low energy electron beam, it is given priority to the Al_2O_3 fluorescent screen. The OTR (optical transition radiation) screen is used as the auxiliary measurement method. The calibration screen is used for calibrating the parameters of optical component.

The assembled detector is shown in Fig. 4. It can be divided into two parts, which are mechanical component and optical component.



Figure 4: The assembled beam profile monitor.

Mechanical Component

It consists of vacuum pipe, viewports, multi-screens and step-servo motor. The axis of the screen can be rotated fine. By the optical setup, we can calibrate the angle between screen and beam accurately.

The movement of multi-screens is controlled by a step-servo motor (MOONS SSM24Q-3RG) in the vertical direction. It integrates with controller, driver, encoder and I/O. The I/O can be used for the illumination control, position or limit switches monitor. The serial server (MOXA DA662) is adopt to communicate with the motor via RS-485 protocol.

Optical Component

It consists of reflector, lenses and CCD camera. All the components are mounted on the rails in shield box. The

light of beam can be extracted from both sides of the detector. In order to reduce the radiation damage, the CCD camera is located below the beam plane.

The Basler SCA1000-30 is chosen, which is Gigabit Ethernet (GigE) progressive scan CCD camera. The pixels are 1034×779, the pixel depth is 12bits. The GigE interface allows for very fast frame rates and long cable lengths. The resolution of the imaging system is 30um, which meet the specification.

Interlock

Since the accelerator work at high repetition frequency (333Hz), the average power can reach 7.5kW. In order to prevent damage to the beam profile monitor, the interlock mechanism has been introduced. The interlock logic is shown in Fig. 5.

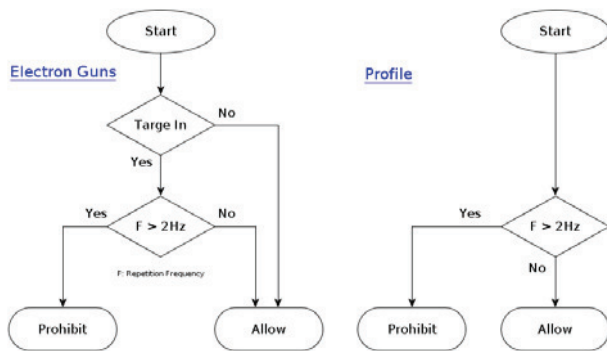

Figure 5: The logic of beam profile interlock.

For the electron gun, it can only be triggered under the conditions of less than 2Hz repetition rate if the screen is inserted. For the beam profile monitor, the screen can only be inserted if the repetition frequency is less than 2Hz.

BEAM CHARGE MEASUREMENT

The integration current transformer (ICT) from Bergoz is employed to measure the beam charge, as shown in Fig. 6. The output signal is connected directly to the oscilloscope, which is purchased from Agilent. The integration function is used to calculate the charge. Besides, the BPM sum signal can also be used for charge measurement after calibration.

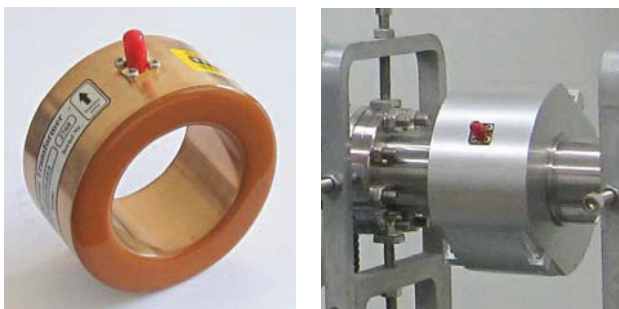

Figure 6: The integration current transformer and customized vacuum component.

DATA ACQUISITION SYSTEM

The data acquisition system is based on EPICS. All IOCs were developed under Linux operating system for high reliability and stability. The systems architect is shown in Fig. 7.

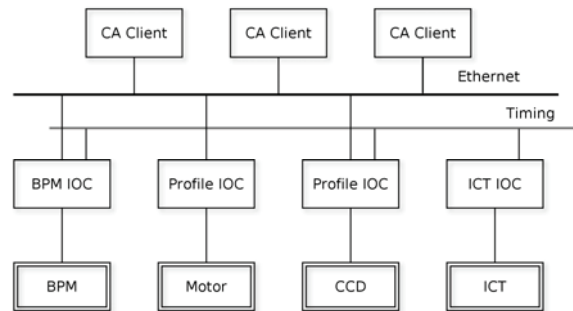

Figure 7: The data acquisition system.

The BPM IOC is an asyn supported port driver that provides access to the Libera BASE framework which is found in I-Tech Platform B instruments. For the energy spread calculation, soft IOC [2] is introduced, which an ideal solution for high level applications.

The step-servo motor IOC is running on the DA662 embedded Linux, which is base on the streamDevice module. The areaDetector is used for beam image acquisition and processing. It acquires the image data from CCD camera via network switch and process on a rack server (IBM System x3550 M3). The plugin architecture of areaDetector is very powerful, complex processing can be easily implemented.

CONCLUSION

Unfortunately the project schedule has been delayed due to some subsystems. The data of beam can not be shown according to the original plan.

Up until now, all the monitors and electronics have been installed on the site. Some testing has been carried in the laboratory. The system will be commissioning the end of this year.

ACKNOWLEDGMENT

We would like to thank everyone who contributed to this work through discussions and suggestions.

REFERENCES

- [1] Libera Single Pass E Specifications 1.00, Instrumentation Technologies, Solkan, Slovenia, (2012).
- [2] Y. B. Yan, Y. B. Leng, Soft IOC Application in SSRF Beam Diagnostics System, IPAC2010, Kyoto, Japan.