

# USING A TE011 CAVITY AS A MAGNETIC MOMENTUM MONITOR\*

J. Guo#, J. Henry, M. Poelker, R. A. Rimmer, R. Suleiman, H. Wang,  
JLAB, Newport News, VA 23606, USA

## Abstract

The Jefferson Lab Electron-Ion Collider (JLEIC) design relies on cooling of the ion beam with bunched electron beam. The bunched beam cooler complex consists of a high current magnetized electron source, an energy recovery linac, a circulating ring, and a pair of long solenoids where the cooling takes place. A non-invasive real time monitoring system is highly desired to quantify electron beam magnetization. The authors propose to use a passive copper RF cavity in TE011 mode as such a monitor. If such a cavity is powered actively, it is also possible to be used as a beam magnetizer.

## INTRODUCTION

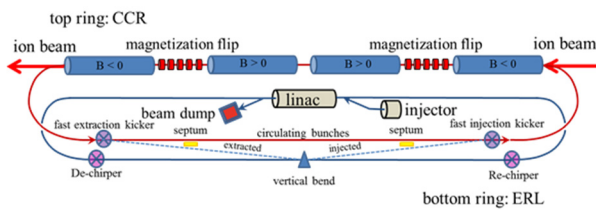

Figure 1: JLEIC Circulating Cooler Ring (CCR).

The proposed JLEIC is a high luminosity electron ion collider. The key to achieve JLEIC's luminosity goal is to maintain low ion emittance through bunched beam electron cooling in solenoid channels during the collision, as shown in Fig. 1. To avoid rotation of the electron beam in the cooling channel, the JLEIC cooling electron beam needs to be magnetized before entering the cooling channel [1]. Magnetized DC electron cooling is also necessary during the JLEIC ion beam formation.

Non-invasive measurement of the magnetic moment of a charged particle beam has long been on the wish-list of beam physicists. The previous efforts were mainly focused on measuring the beam polarization [2, 3, 4], which is in the order of  $\hbar/2$  per electron or proton. Even after enhanced by the Stern-Gerlach polarimetry, the RF signal in the cavity generated by the beam is still extremely hard to measure.

The magnetic moment per particle of the magnetized beam is typically a few orders of magnitude higher. As a demonstration of the source for the JLEIC e-cooler, the magnetized beam generated at JLab GTS [5] can have a magnetic moment  $M=200$  neV-s or  $3.0 \times 10^8 \hbar$ . The JLab GTS beam also has a typical energy of 300 keV and a low

$\gamma$ . These parameters make the magnetic moment more likely to be detected with an RF cavity.

One potential concern of the resonance type magnetic moment monitor is the signal excited by the non-magnetized current, usually due to the longitudinal component of electric field along the beam path. TE011 mode in a cylindrical symmetric cavity will only have azimuthal E-field, making it an ideal candidate for magnetic moment measurement.

## INTERACTION BETWEEN PILLBOX TE011 MODE AND MAGNETIZED BEAM

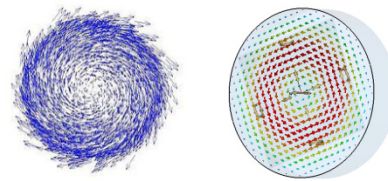

Figure 2: Left: Transverse motion of a longitudinally magnetized beam; Right: Transverse electric field in TE011 mode of a pillbox cavity.

The angular momentum and magnetic momentum of a charged particle is determined by its motion in azimuthal direction, as shown in Fig. 2, left.

$$\begin{aligned} L &= \gamma m \rho^2 \dot{\phi} \\ M &= L \frac{e}{2mc} \end{aligned} \quad (1)$$

For a cylindrical symmetric RF cavity, the electric field of TE011 mode has only azimuthal component, and will be zero in other directions (radial or longitudinal), as shown in Fig. 2, right. In the vicinity of the cavity axle, the TE011 mode azimuthal E-field's amplitude can be approximated as

$$E_{\phi}(z, t, \rho) = E_{\phi}(z, t) \rho \quad (2)$$

Assuming that the beam-cavity interaction has negligible perturbation on beam trajectory,  $\rho^2 \dot{\phi}$  is almost constant during the beam's path through the cavity. By integrating E-field tangential to the particle trajectory, the acceleration voltage when a particle travels through the cavity can be calculated as

$$\begin{aligned} V_{\perp} &= \int E_{\phi}(z, t, \rho) \rho d\phi \\ &= \frac{\rho^2 \dot{\phi}}{\beta c} \int E_{\phi} \left( z, t = \frac{z-z_0}{\beta c} \right) dz \end{aligned} \quad (3)$$

\* Authored by Jefferson Science Associates, LLC under U.S. DOE Contract No. DE-AC05-06OR23177 and supported by Laboratory Directed Research and Development funding. The U.S. Government retains a non-exclusive, paid-up, irrevocable, world-wide license to publish or reproduce this manuscript for U.S. Government purposes #jguo@jlab.org

The cavity transverse R/Q is

$$\frac{R_{\perp}}{Q} = \frac{v_{\perp}^2}{\omega U} \propto (\dot{\phi} \rho^2)^2 \quad (4)$$

The power of the extracted RF signal is

$$P_{emitted} = I^2 \frac{R_{\perp}}{Q} \frac{Q_{loaded}^2}{Q_{ext}} \propto I^2 \langle (M/\gamma)^2 \rangle \quad (5)$$

which is proportional to the square of average magnetic moment of the beam and will be maximized if the cavity has critical coupling.

The cavity is basically detecting the rotation of the beam along the cavity's electric center axle. As a result, it cannot differentiate the rotation of beam center trajectory relative to the cavity's electric center axle. The beam needs to be well aligned to the cavity center to avoid this background. The wire stretching technique [6] can be used to find the cavity's electric center.

### CAVITY RF DESIGN AND SCALING

When the cavity scales with constant aspect ratio, the emitted RF power scales as

$$P_{emitted} \propto \omega^{1.5} \rho^4 \dot{\phi}^2 \quad (6)$$

If the cavity beampipe size is not the limiting factor of the beam's maximum angular moment,  $P_{emitted} \propto \omega^{1.5}$ , so a smaller cavity with higher frequency will be more sensitive to the beam magnetization. With scaled fabrication error, small cavities also have lower longitudinal impedance. However, if the cavity beampipe size limits the beam's size and maximum angular momentum, a larger cavity can produce more RF signal with the same beam current.

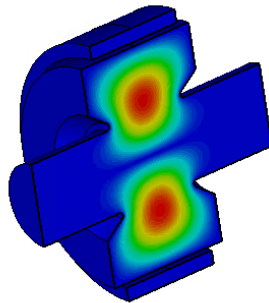

Figure 3: Electric field in the 2994MHz TE011 cavity.

Our final design chose a frequency of 2994 MHz instead of 1497 MHz, as any subharmonic beam can drive the cavity. The smaller cavity has better mechanical strength and is much easier to fabricate. The cavity is basically a pillbox with 2.375" beampipes. Nosecones are added to enhance the transit time factor (TTF) and impedance. The larger relative size of the beampipes resulted in stronger fringe field, cancelled the impedance gained from the reduced cavity size. For  $M=200$  neV-s  $\beta=0.78$  beam, the 2994 MHz cavity  $R_{\perp}/Q$  improves to

15.6  $\mu\Omega$ ; with critical coupling, the transverse impedance  $R_{\perp}=286$  m $\Omega$ , with  $\sim 3.6\mu W$  power expected to be extracted from 5 mA beam. The magnitude of the electric field in the cavity is shown in Fig. 3, and Fig. 4 shows the E-field tangential to the beam trajectory seen by a particle with  $\beta=0.78$  rotating along the 2994 MHz cavity's longitudinal axle.

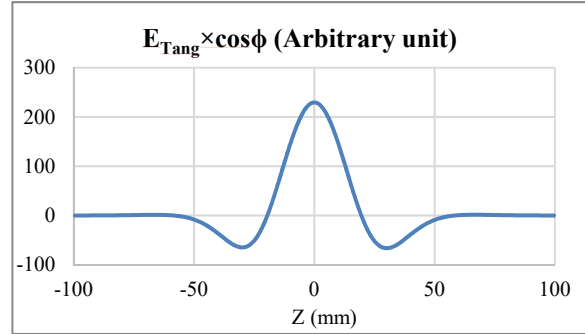

Figure 4: Tangential E-field seen by a  $\beta=0.78$  beam with  $x'=50$  mrad,  $y_0=0.01$  m, equivalent to  $M=2127$  neV-s.

To reduce the background signal excited by the beam current, the longitudinal R/Q in the TE011 mode needs to be controlled significantly below the transverse impedance, likely in  $\sim 100n\Omega$  level, with careful coupler design and fabrication precision.

### Cavity Coupler Design

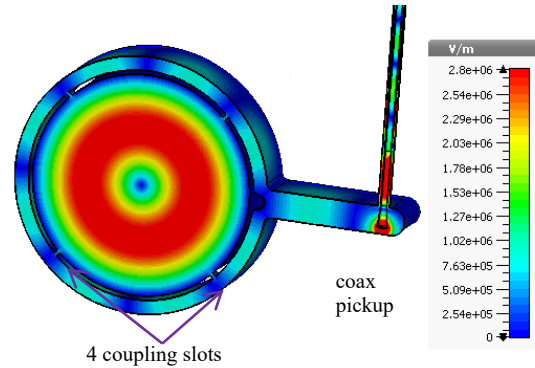

Figure 5: E-field in the coupler.

The coupler design strategy for this cavity to achieve low longitudinal impedance is to preserve the longitudinal mirror symmetry and the cylindrical symmetry as much as possible. We chose a design similar to the SLAC X-band wrap-around rectangular waveguide TE10 to circular TE01 mode launcher [7, 8]. As shown in Fig. 5, the cavity has four equally 90° spaced longitudinal slots coupling to the wrap-around waveguide, and a matched lip combining the two branches of the waveguide. The waveguide width is adjusted so the slot spacing equals  $\lambda_g$ . To make the waveguide width slightly smaller than the optimized cavity length, the number of slots has to be chosen at four. A matched coax pickup will couple to the instruments. The slot size is designed to achieve slight overcoupling based on ideal copper conductivity, budgeting for conductivity loss and mismatch in the coax pickup.

The four slots coupler design will be sensitive to TE(4N)xx modes, and rejects the other modes. This helps to filter out most of the noise from the unwanted modes. The frequencies of TE411 and TE811 modes can be tuned away from possible bunch excited frequencies. For the prototype, the only damping mechanism for the other HOMs and LOMs is the cavity wall loss, which could be sufficient for the purpose of proof-of-principal. For a device to be installed in an operating accelerator, beampipe dampers can be added.

## CAVITY FABRICATION

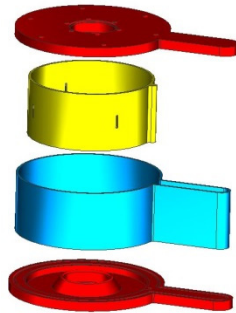

Figure 6: Exploded view of the cavity's copper parts.

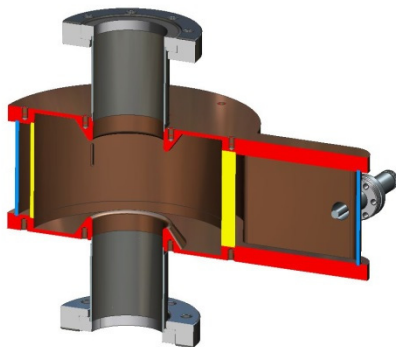

Figure 7: Cut view of the assembled cavity.

The mechanic design and choice of fabrication process for this cavity focus on minimizing the deformation and preserving the symmetry. The main cavity body consists of four parts machined from three blocks of OFHC copper, including two end-plates, the inner cavity wall, and the outer wrap-around waveguide wall, as shown in Fig. 6. The copper material was stress relieved before machining. The parts are machined with high precision wire EDM (electrical discharge machining). The four copper parts and two stainless steel beampipes will be brazed together, as shown in Fig. 7. RF bench measurement can be done by clamping the parts together before the final braze. Currently the cavity parts are being machined by our collaborator Electrodynamic in Albuquerque, NM. Figure 8 shows the test piece inner/outer wall machined with one piece of aluminium.

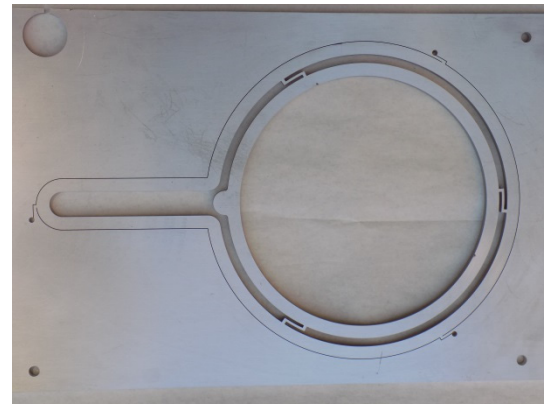

Figure 8: Cavity inner/outer wall wire EDM with a thin test piece of aluminium.

## SUMMARY

We proposed and designed a Beam Magnetic Momentum Monitor using an RF cavity in TE011 mode. The RF signal power excited by the beam is theoretically proportional to the square of the beam's magnetic momentum. For low energy beam (not fully relativistic), the cavity could provide sufficient signal strength and low noise. The prototype cavity is under fabrication. Such a cavity also has the potential to be adopted for Stern-Gerlach polarimetry, with possible improved sensitivity and noise level compared to previous attempts.

## REFERENCES

- [1] S. Abeyratne *et al.*, "MEIC Design Summary", 2015, arXiv:1504.07961
- [2] Ya. S. Derbenev, "RF-resonance Beam Polarimeter: Part 1. Fundamental Concepts", *Nucl. Instr. Meth. A*, vol. 336, pp. 12-15, 1993.
- [3] M. Conte *et al.*, "The Stern-Gerlach Interaction between a travelling particle and a time varying magnetic field", arXiv:physics/0003069v1
- [4] P. Cameron *et al.*, "Proposal for a Cavity Polarimeter at MIT-Bates", in *Proc. PAC'01*, Chicago, May 2001, paper WPAH136.
- [5] M. Mamun *et al.*, "Production of Magnetized Electron Beam from a DC High Voltage Photogun", in *Proc. IPAC'18*, Vancouver, BC, Canada, May 2018. doi:10.18429/JACoW-IPAC2018-THPMK108
- [6] G. Park *et al.*, "Improvement of Wire-Stretching Technique to the RF Measurements of E-Center and Multipole Field for the Dipole Cavities", in *Proc. IPAC'18*, Vancouver, BC, Canada. doi:10.18429/JACoW-IPAC2018-THPML095
- [7] S. Tantawi *et al.*, "The Generation of 400-MW RF Pulses at X-Band Using Resonant Delay Lines", *IEEE Trans. on MTT*, vol. 47, no. 12, Dec. 1999
- [8] C. Nantista, "Overmoded Waveguide Components for High-Power RF", in *Proc. 6th Workshop on High Energy Density and High Power RF*, Berkeley Springs, West Virginia, Jun. 2003, *AIP Conference Proceedings*, vol. 691, p. 263, 2003, <https://doi.org/10.1063/1.1635127>