

INITIAL RESULTS FROM THE LHC MULTI-BAND INSTABILITY MONITOR

T.E. Levens*, T. Lefevre, D. Valuch, CERN, Geneva, Switzerland

Abstract

Intra-bunch transverse instabilities are routinely measured in the LHC using a “Head-Tail Monitor” based on sampling a wide-band BPM with a high-speed digitiser. However, these measurements are limited by the dynamic range and short record length possible with typical commercial oscilloscopes. This paper will present the initial results from the LHC Multi-Band Instability Monitor, a new technique developed to provide information on the beam stability with a high dynamic range using frequency domain analysis of the transverse beam spectrum.

INTRODUCTION

Transverse beam instabilities are regularly observed during routine operation of the Large Hadron Collider (LHC). As many of the sources of instabilities scale with the bunch intensity and emittance, their mitigation remains an important consideration for delivering the maximum luminosity to the LHC’s experiments. Regular studies into the causes of these instabilities are performed during dedicated “machine development” sessions [1] in order to find adequate mitigation techniques [2]. In addition to these studies, it is important to have instrumentation available that can diagnose any instabilities that may occur during regular operation.

A fundamental tool for the measurement of transverse instabilities is the LHC “Head-Tail Monitor” [3] which can resolve the intra-bunch beam position by sampling a wide-band beam position monitor (BPM) with a fast oscilloscope. Similar techniques have been used since the first direct observation of transverse instabilities in CERN’s PS and Booster in the 1970s [4]. However, the short bunch length in the LHC ($4\sigma \approx 1.1$ ns) requires sampling at a much higher rate than has been previously necessary, up to 10 GSPS in the case of the LHC.

While the Head-Tail Monitor provides a direct measurement of the intra-bunch motion, and is an important tool for instability studies, it poses a number of challenges for use during regular operation. The original oscilloscopes used in the LHC could provide a maximum of 11 turns of data every 15 seconds. Furthermore, due to the limited dynamic range of their 8-bit high-speed digitisers, only larger oscillation amplitudes were visible. These limitations lead to the development of an online trigger system to precisely trigger the acquisition during an instability [5]. For the 2018 LHC run, new 10-bit oscilloscopes have been installed which offer a higher dynamic range and longer acquisition lengths of up to 450 turns. While easing the demands for precise triggering, the increase in data size of up to 3 GB per acquisition makes data processing and storage challenging.

* tom.levens@cern.ch

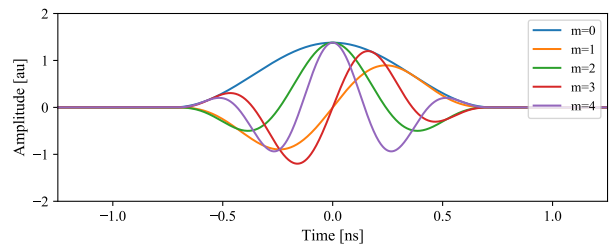

(a) time domain

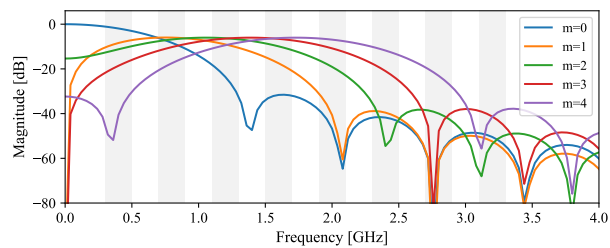

(b) frequency domain

Figure 1: Simulated comparison of time domain (a) and frequency domain (b) analysis for a typical LHC bunch with head-tail instability modes 0 to 4.

As an alternative to “brute-force” time domain sampling, the Multi-Band Instability Monitor (MIM) uses a frequency domain approach to measure intra-bunch motion. Similar techniques are often used on very short electron bunches where the spectrum extends to frequencies that cannot be easily measured directly by temporal detection schemes [6]. As shown in Fig. 1, it is expected that for an unstable bunch there will be a shift in the spectral power to higher frequencies as the instability mode increases. In order to measure this shift, the signal from a wideband BPM is split into a number of frequency bands using a bank of radio frequency (RF) band-pass filters. Each band can then be mixed down to base-band and digitised in parallel. As the signal from each band has limited bandwidth, it can be digitised at a much higher resolution than would be possible for the wideband BPM signal. While full time domain reconstruction would require amplitude and phase information from each band, with only the amplitude it is still possible to determine the mode from the relative power in the bands. This simplification permits the use of highly sensitive diode detectors, as are used in the LHC’s base-band tune (BBQ) system [7].

After the MIM concept was first demonstrated in the SPS and LHC [8], it has also been tested for short electron bunches using an “optical BPM” at the Australian Synchrotron, measuring synchrotron radiation in three frequency bands up to 12 GHz [9]. In this paper we present the first results from the fully implement MIM system in the LHC.

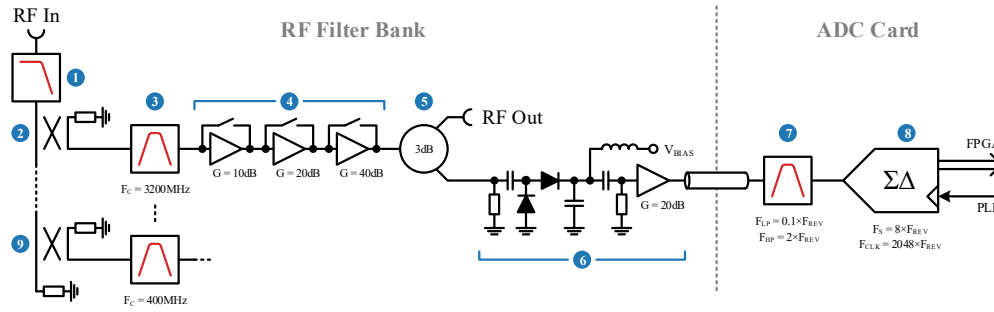

Figure 2: Layout showing a single band of the MIM front-end. Elements: ❶ image suppression low-pass filter; ❷ directional coupler for highest band; ❸ RF band-pass filter; ❹ RF programmable gain amplifier (PGA); ❺ 3 dB Wilkinson divider; ❻ diode detector; ❼ base-band filter; ❽ analogue to digital converter (ADC); ❾ directional coupler for lowest band.

MIM HARDWARE DESIGN

The LHC MIM RF front-end consists of a bank of band-pass filters to select different components of the beam spectrum. Figure 2 shows the layout of the front-end. For each band, a portion of the difference signal from a BPM is coupled from a “through-line” with a directional coupler. The filters are implemented as a strip-line structures on an internal layer of a PCB, shown in Fig. 3a, allowing precise control of the RF properties. As this topology of filter exhibits a periodic frequency response at odd multiples of the centre frequency, lumped low-pass filters in the through-line suppress the unwanted high-frequency signal from subsequent bands. The bandwidth of each filter is approximately 200 MHz and was optimised in order to limit the ringing of the filter output to 25 ns. Although the current implementation of the MIM is not capable of making bunch-by-bunch measurements, this consideration allows the potential in the future. A network analyser measurement of the filter bank is shown in Fig. 3b.

After filtering, a RF programmable gain amplifier (PGA) provides up to 70 dB amplification in 10 dB steps to compensate for the expected difference in signal level between the bands. The amplified signal is split using a 3 dB Wilkinson divider to provide both a RF output for monitoring, and to feed the input of a diode detector. The detector diodes are connected as a voltage doubler [10] and DC biased to provide maximum sensitivity. Finally, the base-band output of the detector is band-pass filtered and digitised using a high resolution 24-bit sigma-delta ADC sampling at a multiple of the revolution frequency (F_{REV}).

Two RF filter banks are packaged into a 2U front-end chassis, shown in Fig. 4. Each of the sixteen ADC channels is implemented on an individual PCB that is mounted on a custom “backplane” for power and data distribution. A fractional phase locked loop (PLL) generates the required $2048 \times F_{REV}$ ADC clock from the 40 MHz beam-synchronous clock ($3564 \times F_{REV}$). A Xilinx Zynq 7030 FPGA is used to interface to the ADCs and includes a dual-core ARM processor running an embedded Linux distribution. The processor can run real-time signal processing algorithms directly and allows control and data acquisition over Ethernet.

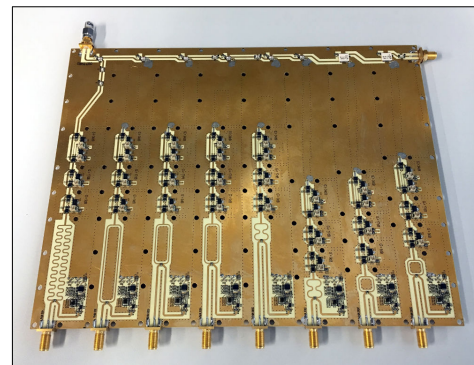

(a) PCB

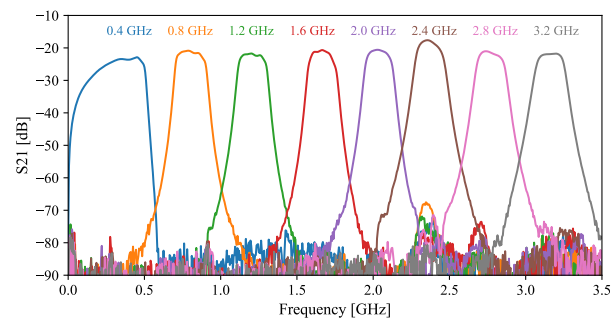

(b) measured frequency response

Figure 3: MIM RF filter bank PCB and frequency response measured with a vector network analyser.



Figure 4: MIM front-end chassis.

MIM MEASUREMENT RESULTS

Tune Measurements

Since the BBQ is known to be sensitive to oscillations at a sub-micron level, making a betatron tune measurement with the MIM and comparing it to that obtained with the BBQ can reveal some indication of the sensitivity of the MIM. A comparison of the spectra obtained from the BBQ and the 400 MHz band of the MIM during a normal LHC physics fill with 2556 bunches at 6.5 TeV is shown in Fig. 5. While it is clear that the MIM has a higher noise floor than the BBQ, which would limit the sensitivity for single bunch measurements, with a large number of bunches the spectrum is remarkably similar between the two instruments.

It is notable that the prominent peaks, appearing at multiples of 50 Hz, that are commonly seen the BBQ are also present in the MIM spectrum with a very similar amplitude. The source of these lines, which are more extreme in the horizontal plane and only appear after injecting a large number of bunches, is not well understood and different perturbation sources are currently being studied. One question is whether these lines only appear close to DC or whether they are also present at a higher frequencies. It is not possible to determine this from the BBQ as it is limited to acquiring the spectrum between DC and $0.5 \times F_{REV}$ due to the aggressive analogue band-pass and notch filtering in the front-end and the limited sampling rate of the high-resolution audio ADCs used for acquisition.

In contrast, the base-band band-pass filters in the MIM have a cut-off frequency of $2 \times F_{REV}$ and have a slow roll-off allowing the spectrum well above the first revolution frequency line to be acquired. Figure 6 shows the spectrum recorded with the MIM up to the eighth revolution harmonic with a zoom of the spectrum up to the second revolution harmonic. While the 50 Hz lines are very evident around the base-band tune (Q) and lower revolution side-band ($F_{REV} - Q$), they disappear completely above approximately 8 KHz. An interesting observation is that the upper revolution side-band ($F_{REV} + Q$) is clean allowing much better measurements than the base-band. This side-band has been used for the MIM instability analysis. The possibility of modifying the BBQ front-end electronics and acquisition system to observe this side-band is currently being studied.

Instability Measurements

Data from the MIM has been recorded during a number of dedicated machine development sessions where the machine parameters (chromaticity, octupole strength, etc) are varied in order to study the impact on instabilities [11]. Figure 7 shows an example of a measurement made with the MIM during a study on 3rd December 2017 that was aimed at comparing the instability threshold between trains that had different bunch structures. At flat-top energy, the main octupole strength was progressively lowered until the bunches started to become unstable. The plots cover approximately

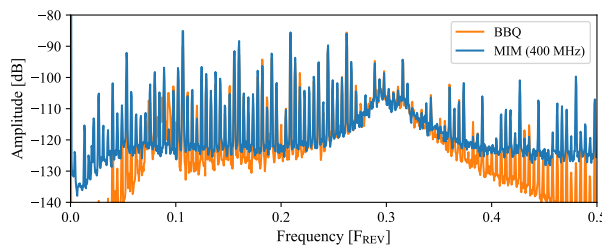

Figure 5: Comparison between tune spectrum measured with BBQ and 400 MHz band of the MIM during a normal LHC physics fill with 2556 bunches.

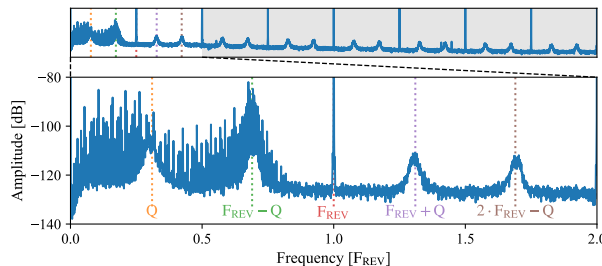

Figure 6: Spectrum from 400 MHz MIM band extended up to the eighth revolution harmonic with a zoom of the spectrum up to the second harmonic.

eight minutes starting at 02:50 during which time different bunches in a train became unstable sequentially.

Figure 7a shows spectrograms of the MIM bands, zoomed around the nominal horizontal betatron tune value of approx. 0.27 in order to show only the tune side-band. Plotting the peak value of the F_{REV} line and tune side-band, as done in Fig. 7b allows the growth of the instabilities to be more clearly visualised. Three measurements from the Head-Tail Monitor are shown in Fig. 7c with timestamps corresponding to the dashed lines in Fig. 7b.

A first instability event is evident around 02:51, visible as an increase in amplitude around the betatron frequency. During this event, the Head-Tail monitor shows a single bunch becoming unstable with a mode $m=2$ with an amplitude below $100 \mu\text{m}$. While this instability is barely visible on the Head-Tail Monitor, it shows a clear signature in the MIM bands. Figure 7d shows the reconstruction of the relative power in the bands at the moment of the Head-Tail measurement. The distribution matches the expectation for a mode $m=2$ with a peak in region of 1.2 to 1.6 GHz band and notches in the 2.4 and 3.2 GHz bands.

A second event starts around 02:52 and continues until the end of the acquisition. A different bunch in the train first goes unstable with an amplitude of around $200 \mu\text{m}$, again resulting in a very clear rise in power from the MIM bands. From the spectrogram it is possible to see that the initial rise of this instability happens on a different synchrotron side-band of the tune indicating a different azimuthal instability mode number. As the event proceeds multiple bunches become unstable at the same time which result in multiple peaks in the tune spectrum at different synchrotron side-bands. Again

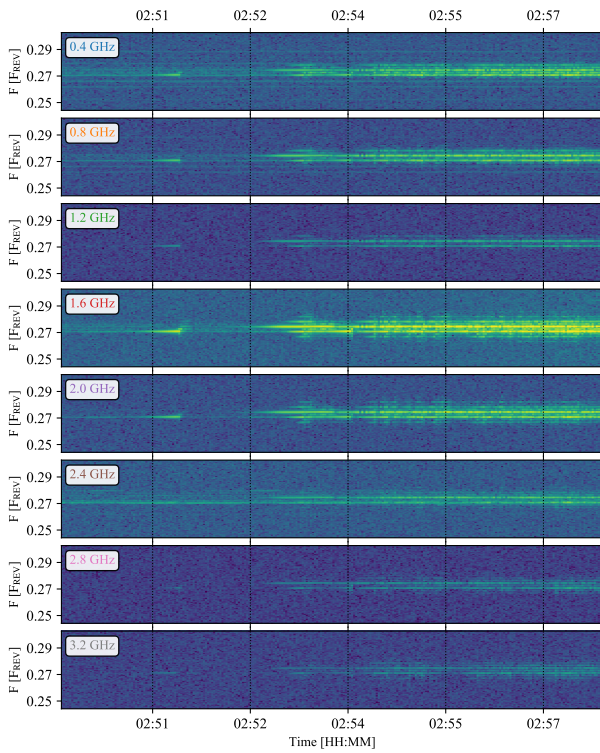

(a) MIM spectrogram

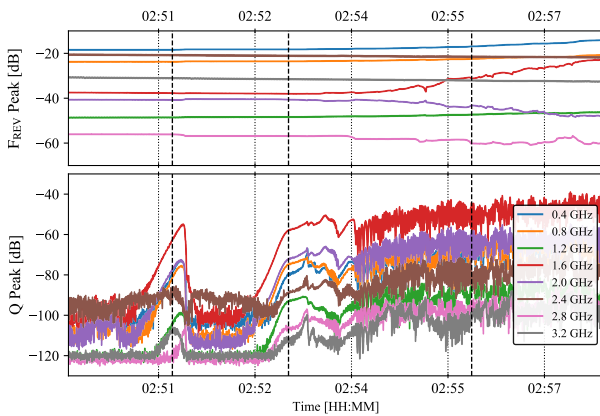

(b) MIM F_{REV} and tune peak amplitudes

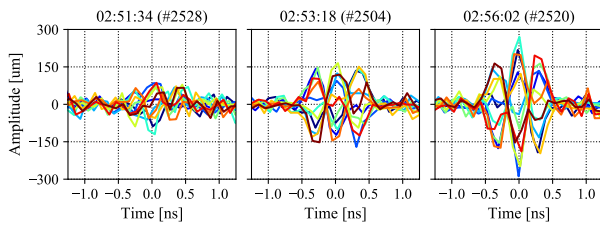

(c) Head-Tail delta signal

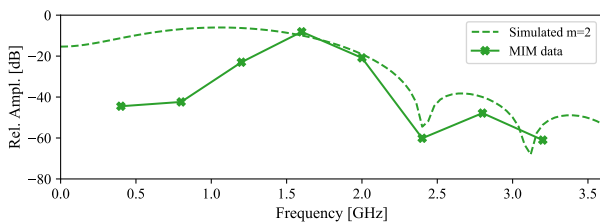

(d) MIM reconstruction

Figure 7: An instability recorded during a machine development session on 3rd Dec. 2017 from 02:50 to 02:58.

the Head-Tail reveals clear $m=2$ oscillations with amplitudes around 300 μm . Also notable during the second event is that there is a change in power of the F_{REV} peak in the higher bands as the instability progresses, which is indicative of a distortion of the longitudinal bunch shape.

CONCLUSION

A new Multi-Band Instability Monitor has been developed for the LHC based on the analysis of independent frequency bands of the transverse beam spectrum. The RF filter bank provides eight bands from 400 MHz to 3.2 GHz, each of which is detected using a high-sensitivity diode detector and sampled with a high-resolution ADC. The initial results show that the sensitivity achieved for a full machine is similar to the BBQ and the increased sampling rate of the ADCs provides some insight into the nature of the 50 Hz lines which are a common feature of the LHC tune spectra. During known instabilities a clear increase in signal power is seen in all of the bands and the and their ratio is indicative of the mode of the instability. Future work will focus on developing a real time identification of the instability mode for instabilities occurring during normal operation.

REFERENCES

- [1] L.R. Carver *et al.*, “Transverse beam instabilities in the presence of linear coupling in the large hadron collider”, *Physical Review Accelerator and Beams*, vol. 21, p. 044401, 2018. doi: 10.1103/PhysRevAccelBeams.21.044401
- [2] M. Schenk *et al.*, “Experimental stabilization of transverse collective instabilities in the LHC with second order chromaticity”, *Physical Review Accelerator and Beams*, vol. 21, p. 084401, 2018. doi: 10.1103/PhysRevAccelBeams.21.084401
- [3] R. Jones *et al.*, “Recent Advances in the Measurement of Chromaticity via Head-Tail Phase Shift Analysis”, in *Proceedings of DIPAC03*, Mainz, Germany, 2003, paper PM08, pp. 107–109.
- [4] J. Gareyte, “Head-tail type instabilities of the CERN PS and Booster, pt 1-2”, CERN, Geneva, Switzerland, Rep. CERN-MPS-BR-74-7, 1974.
- [5] T.E. Levens, K. Lasocha, and T. Lefevre, “Recent developments for instability monitoring at the LHC”, in *Proceedings of IBIC2016*, Barcelona, Spain, 2016, pp. 853–856. doi: 10.18429/JACoW-IBIC2016-THAL02
- [6] A.E. Dabrowski *et al.*, “Measuring the bunch frequency multiplication at the 3rd CLIC test facility”, *Journal of Instrumentation*, vol. 7, p. P01005, 2012.
- [7] M. Gasior, “Faraday cup award: high sensitivity tune measurement using direct diode detection”, in *Proceedings of BIW2012*, Newport News, VA USA, 2012, paper MOAP02, pp. 1–8.
- [8] R.J. Steinhagen, M.J. Boland, and T.G. Lucas, “A Multiband-Instability-Monitor for High-Frequency Intra-Bunch Beam Diagnostics”, in *Proceedings of IBIC2013*, Oxford, UK, 2013, paper TUBL3, pp. 327–330.

- Content from this work may be used under the terms of the CC BY 3.0 licence (© 2018). Any distribution of this work must maintain attribution to the author(s), title of the work, publisher, and DOI.
- [9] T.G. Lucas *et al.*, “An optical intra-bunch instability monitor for short electron bunches”, in *Proceedings of IBIC2015*, Melbourne, Australia, 2015, pp. 161–164. doi:10.18429/JACoW-IBIC2015-M0PB049
- [10] Hewlett-Packard Co., “Schottky diode voltage doubler”, Application Note 956-4, 1995.
- [11] L.R. Carver *et al.*, “Current status of instability threshold measurements in the LHC at 6.5 TeV”, in *Proceedings of IPAC2016*, Busan, Korea, 2016, pp. 1434–1437. doi:10.18429/JACoW-IPAC2016-TUPMW011