

CONTROL PROGRAMS FOR THE MANTRA PROJECT AT THE ATLAS SUPERCONDUCTING ACCELERATOR*

M. Power, C. Davids, C. Nair, T. Palchan, R. Pardo, C. Peters, K. Teh, R. Vondrasek
ANL, Argonne, IL 60439, USA

Abstract

The AMS (Accelerator Mass Spectrometry) project at ATLAS (Argonne Tandem Linac Accelerator System) complements the MANTRA (Measurement of Actinides Neutron TRAnsmutation) experimental campaign. To improve the precision and accuracy of AMS measurements at ATLAS, a new overall control system for AMS measurements needs to be implemented to reduce systematic errors arising from changes in transmission and ion source operation. The system will automatically and rapidly switch between different m/q settings, acquire the appropriate data and move on to the next setting. In addition to controlling the new multi-sample changer and laser ablation system, a master control program will communicate via the network to integrate the ATLAS accelerator control system, FMA control computer, and the data acquisition system.

INTRODUCTION

The MANTRA (Measurement of Actinides Neutron TRAnsmutation) project uses Accelerator Mass Spectrometry (AMS) at the ATLAS facility to measure neutron capture rates on a wide range of actinides in a reactor environment. The project requires the measurement of many samples with high precision and accuracy. Laser ablation is used to feed the actinide material into the ECR ion source. A multi-sample holder/changer is used to allow a quick change between multiple samples. [1]

A recent AMS experiment on ^{146}Sm [2] highlighted the need to run ATLAS in an extremely stable mode and demonstrated the feasibility to switch rapidly between various isotopes by computer control of the machine components' setup. Additional methods have also been implemented in order to accomplish setting various devices so that the transmission stability and characterization is maintained. [3].

The Master Control Program will coordinate the various different systems in order to allow automatic configuration changing and recording data of the various isotopes. The systems include the ATLAS Control System and its various subsystems, the FMA (Fragment Mass Analyzer), and the Scarlet Data Acquisition system. All of these systems are based upon completely different software and different communication methods.

*This work was supported by the U.S. Department of Energy, Office of Nuclear Physics, under Contract No. DE-AC02-06CH11357.

MASTER CONTROL PROGRAM

The Master Control Program is a multi-threaded Linux TCP/IP socket server. It accepts and sends various commands to the multiple systems. Scripts are created to coordinate the changing of the beam settings for various source samples and m/q settings. Commands within the scripts communicate to the various systems to coordinate the process of changing samples and beamline settings and data acquisition. Figure 1 shows a sample script used by the Master Control Program.

After any command, or any complex command, the server will automatically send the "OK" or "OK_COMPLETE" status to the client. At any time, the client can poll the server for the status.

# Sample Script	# Acquire Data
f1: insertcup fcp303	d1:begin
a1:begin	insertattn att004
insertcup fcp303	insertcup fca801
changecone 3	end
implement Sm151.snp	wait -t 20 d1
end	r1:readcur fca802
wait -t 10 a1	wait -t 20 d2
#FMA SETUP	

Figure 1: Sample Script for the Master Control Program.

The basic tasks the Master Control Program will perform for an experiment's sample change will include the following steps:

1. Stop data acquisition
2. Stop beam (close faraday cups)
3. Change cone sample on source
4. Load new beamline settings
5. Wait for response from control system for changes complete status
6. Send new Mass, Energy, and Charge State values to FMA
7. Take energy readings by inserting faraday cup and reading the current
8. Send Mass, Energy, and Charge State settings to Data Acquisition system.
9. Record status for reference

ATLAS CONTROL SYSTEM

The real-time software aspects of the control system are handled by Vista Control Systems' software package "Vsystem" [4]. Vsystem is a networked and distributed control system software that provides distributed database access. The package includes a library of callable database access routines, several database access utilities, and a GUI display process. At ATLAS, Vsystem runs on

the HP OpenVMS, Microsoft Windows, and Linux operating system platforms.

Several subsystems of the ATLAS Control System are used for the MANTRA project and detailed below.

ECR Laser Ablation

The AMS technique at ATLAS is based on production of highly-charged positive ions in an ECRIS followed by injection into a linear accelerator. We use a picosecond laser to ablate the actinide material into the ion source.

The installation of the laser at the source is shown in Figure 2. The laser beam is delivered into the source through the extraction aperture. The ablation target is located at the rear of the ECR chamber near the adage of the plasma. [5]

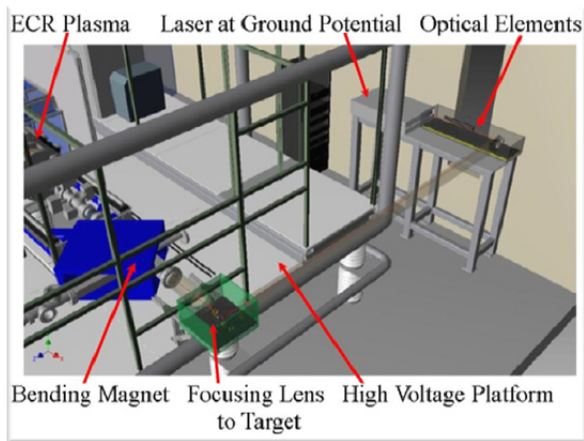

Figure 2: Laser ablation installed on the ECRIS.

The laser system is controlled through RS-232 based serial communication with a third-party provided laser and integrated into Vsystem via a custom driver on a Linux platform. This allows for full control and monitoring in the same way as the third-party Windows based control package provided with the laser. Using the custom driver extends the laser to be controlled by the Master Clock Program via the Vsystem databases or manually by the user via a Vsystem control window shown in Figure 3.

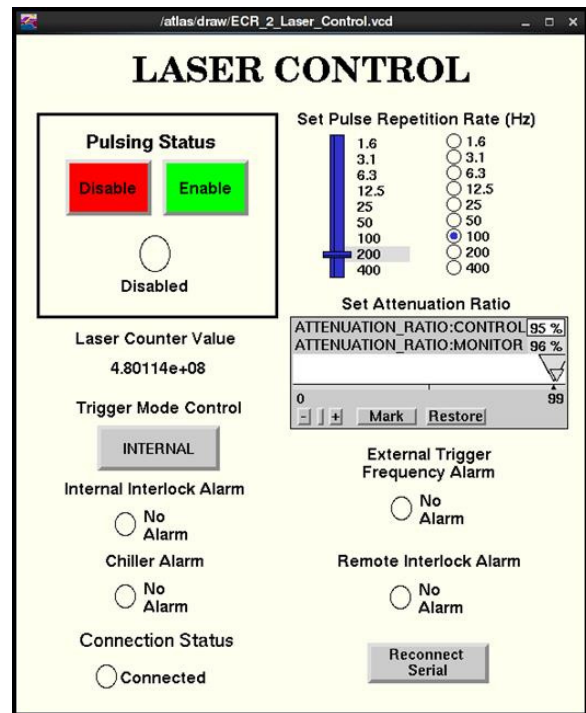

Figure 3: Vsystem laser control window.

LabVIEW [6] is used on a Windows system to sample the laser energy. It compares the energy level with a setpoint and communicates to the Master Control Program to adjust Laser Attenuation accordingly (Figure 4) via the LASERATTEN ‘plus’ or ‘minus’ command.

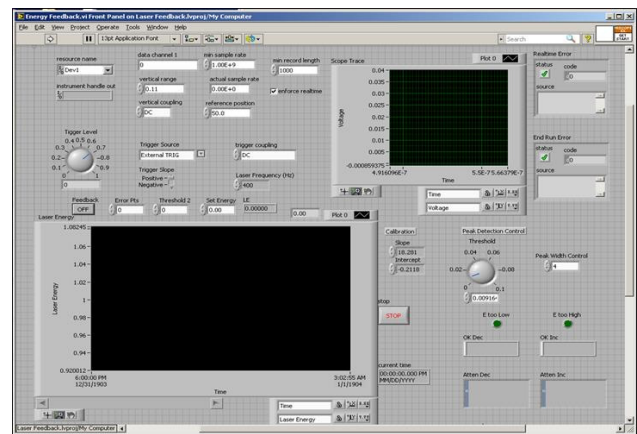

Figure 4: LabVIEW window sampling the laser energy.

Multi-sample Changer

The multi-sample changer (Figure 5) allows the system to automatically change between up to 20 different samples within the source. First, the linear stepper motor retracts the original sample from the chamber. Next, the rotational stepper motor moves the requested sample to the insertion point. Finally, the linear stepper motor inserts the new sample into place [7].

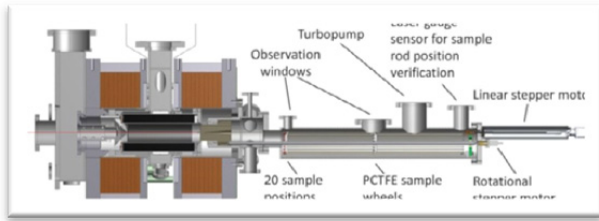

Figure 5: Multi-sample changer.

The stepper motors are controlled through the Vsystem software using serial connections to a VME crate.

The user can manually control the device through a Vsystem control window shown in Figure 6. The Master Control Program can also change the sample through the Vsystem software via the CHANGECON directive.

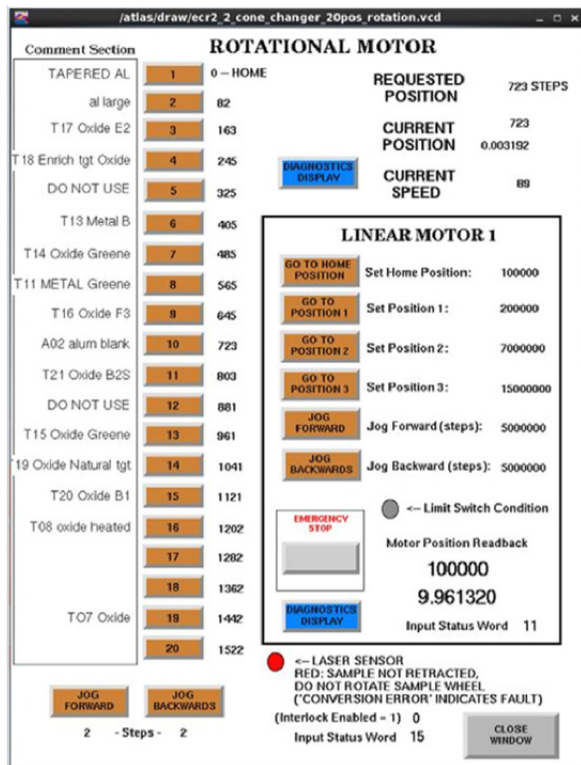

Figure 6: Multi-sample changer Vsystem control window.

Capture/Restore Settings

The capture/restore utility allows the experimenter/operator to save the control settings for the beamline devices and restore them back quickly and accurately (Figure 7). This allows the experimenter to quickly change between multiple elements and charge states. Magnetic devices are ramped appropriately to ensure equivalent field settings. The Master Control Program can initiate a load via the IMPLEMENT command.

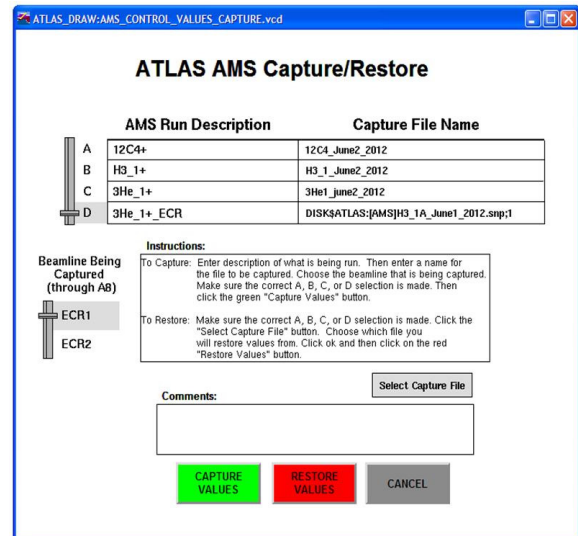

Figure 7: Capture/Restore beamline settings control window.

Additional Control System Modifications for MANTRA/AMS Experiments

Additional modifications have been made in order to ensure the accuracy of these AMS experiments. Field control mode on all magnets continuously monitors the field value and adjusts the control current to maintain the field within the specified tolerance.

Also, a specialized alarming system places tight alarm parameters on the ion source, magnet field readings, and beam guidance channels. Generally, the devices will alarm outside of 1% of the "correct" value or in the case of the magnets, outside of 2 Gauss difference. The Extraction Voltage monitors are alarmed beyond 1x10-4 of the set value (Figure 8).

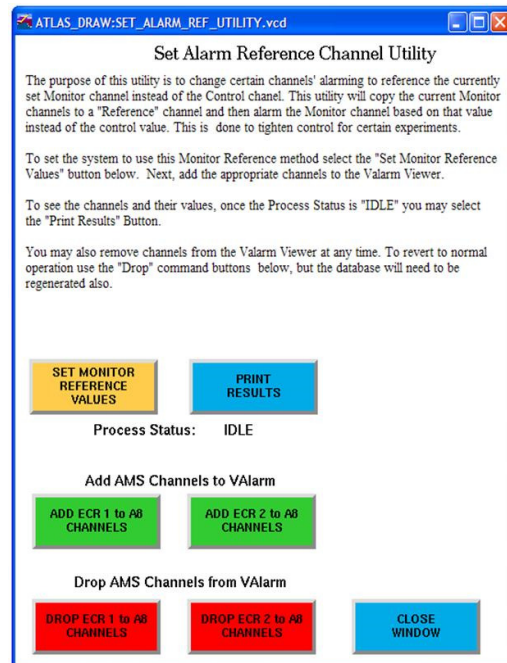

Figure 8: Alarm Reference control window.

The Master Control Program can also command a Faraday Cup to insert and take energy readings via the INSERTCUP, READCUR, and REMOVECUP commands.

FMA

The Fragment Mass Analyzer (FMA) target control system (Figure 9) is run on a Macintosh system and is connected to the Master Control Program via a serial connection. The Master Control Program will communicate the mass, energy, and charge information to and from the FMA control computer.

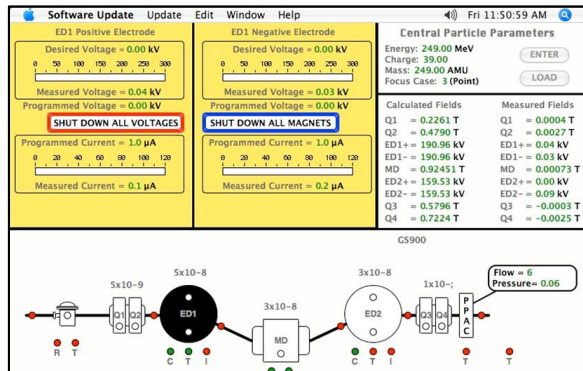

Figure 9: The FMA control system.

DATA ACQUISITION SYSTEM

The Scarlet Data Acquisition system will be instructed as needed to take data for the experiment and provided the energy, mass, and charge state information by the Master Control Program. The DAQ is located on a separate TCP/IP network and communicates with the Master Control Program through TCP/IP sockets.

REFERENCES

- [1] R.C. Pardo, F.G. Kondev, S. Kondrashev, C. Nair, T. Palchan, E. Rehm, R. Scott, R. Vondrasek, M. Paul, P. Collon, G. Youinou, M. Salvatores, G. Palmotti, C. McGrath, G. Imel, "Plans for Laser Ablation of Actinides into an ECRIS for Accelerator Mass Spectroscopy", Proceedings of ECRIS2010, Grenoble, France, TUPOT001, pp110-113.
- [2] N. Kinoshita, T. Hashimoto, T. Nakanishi, A. Yokoyama, H. Amakawa, T. Mitsugashira, T. Ohtsuki, N. Takahashi, I. Ahmad, J. P. Greene, D. J. Henderson, C. L. Jiang, M. Notani, R. C. Pardo, N. Patel, K. E. Rehm, R. Scott, R. Vondrasek, L. Jisonna, P. Collon, D. Robertson, R. Schmitt, X. D. Tang, Y. Kashiv, H. Nassar and M. Paul, J. Phys. G.: Nucl. Part. Phys. 35, 014033 (2008).
- [3] M. Power, C.E. Peters, "Are you customer focused? User Specified Control System Modifications for the Argonne Tandem LINAC Accelerator System (ATLAS)", Workshop on Accelerator Operations, Aug. 6-10, 2012, SLAC National Accelerator Laboratory, Menlo Park, CA.
- [4] Vista Control Systems, Inc., Los Alamos, NM, USA.
- [5] T. Palchan, R. Pardo, F. Kondev, S. Kondrashev, C. Nair, R. Scott, R. Vondrasek, M. Paul, W. Bauder, P. Collon, G. Youinou, M. Salvatores, G. Palmotti, J. Berg, T. Maddock, and G. Imel, "Laser Ablation of Solids Into An Electron Cyclotron Resonance Ion Sources For Accelerator Mass Spectroscopy", TUC03, Proceedings of HIAT 2012, Chicago, IL USA.
- [6] National Instruments LabVIEW, www.ni.com/labview/
- [7] R. Vondrasek, T. Palchan, R. Pardo, C. Peters, M. Power, R. Scott, "A Multi-sample Changer Coupled to an ECR Source for AMS Experiments", Proceedings of the 15th International Conference on Ion Source, Chiba, Japan, September, 2013.