

RE-ENGINEERING CONTROL SYSTEMS USING AUTOMATIC GENERATION TOOLS AND PROCESS SIMULATION: THE LHC WATER COOLING CASE

B. Bradu, E. Blanco, W. Booth, L. Gomez, M. Quilichini, D. Willeman
CERN, Geneva, Switzerland

Abstract

This paper presents the approach used at CERN (European Organization for Nuclear Research) to perform the re-engineering of the control systems dedicated to the LHC (Large Hadron Collider) water cooling systems. It concerns the re-engineering of around 20 PLC (Programmable Logic Controllers) managing around 11000 Inputs/Outputs over 27 kilometers of the accelerator. These cooling systems are composed of cooling towers, chilled water production units and water distribution systems. Due to the very short timescale for these re-engineering projects, due to scheduling constraints for LS1, the first long shutdown of the LHC in 2013-2014, each PLC had to be completely re-commissioned on-site within only three weeks. To achieve this challenge, automatic generation tools were used with the CERN control framework UNICOS-CPC (Unified Industrial Control System for Continuous Process Control) to produce the PLC code. Moreover, dynamic process simulations using the software EcosimPro were also developed to perform virtual commissioning of the new control systems for the most critical processes in order to minimize the real commissioning time on site.

INTRODUCTION

The Large Hadron Collider (LHC) is a circular 27 km accelerator using superconducting magnets where a significant amount of cooling water is required along the ring for different purposes. To provide water to the different clients, several water plants have been setup to extract around 160 MW heat between 34 C and 24 C:

- **SF**: Primary water cooling systems using cooling towers and providing cooling capacity for cryogenic plants, demineralized water distribution plants and chilled water plants (Figure 1).
- **SU**: Chilled water production and distribution, mainly for ventilation and air conditioning for the LHC tunnel.
- **UW**: Distribution of demineralized water to the 100 meters underground LHC tunnel for different clients (power converters, collimators, cables, etc.).

Table 1 summarizes the different industrial equipment composing the LHC water cooling system.

Table 1: LHC Water Cooling Equipment

Equipment	LHC
Cooling towers	25
Chilled water plants	9
Pumping stations	12
Pipes length (km)	520
Pumps	120
Air compressors	22

In total, the LHC comprises 6 SF, 11 SU and 4 UW plants with a total of about 11 000 Inputs/Outputs (I/O). The process control of those plants is based on PLCs (Programmable Logic Controller) and a SCADA (Supervisory Control and Data Acquisition).

The controls of these water cooling plants were originally outsourced by CERN to different firms and they started showing maintenance problems both at the PLC and the SCADA layers.

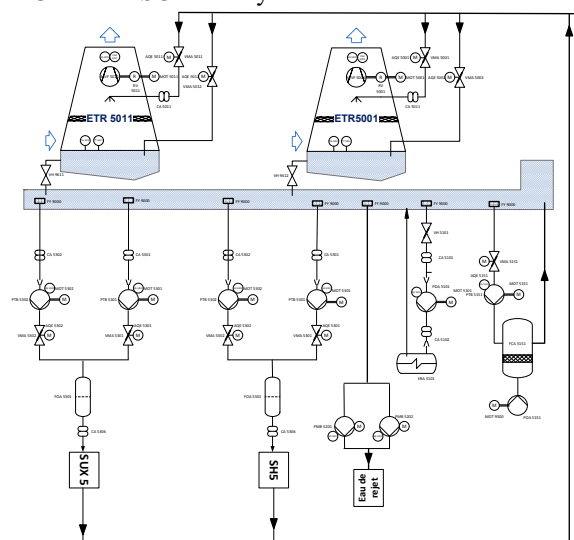

Figure 1: SF primary circuits of LHC Point 5.

In 2010, CERN decided to unify the control systems for the cooling and ventilation systems in order to ease the operation and the maintenance during the next decades using the CERN control standard UNICOS-CPC [1]. This package is dedicated to industrial process control systems. After several control projects in the domain of cooling and ventilation with UNICOS-CPC, it has been decided to upgrade the control of the LHC water cooling plants

during the Long Shutdown 1 (LS1) of LHC in 2013-2014. The re-engineering of each control system is decomposed as follows:

- Recovery and checking of the latest I/O inventory and Process and Instrumentation Diagrams (PIDs).
- Re-engineering of the existing PLC program code to create a functional analysis based on IEC61512-1 [2] containing all the detailed logic and the interlocks managed by the control system.
- Add additional functionality to improve the plant accessibility and availability based on the last years of operational experience as required by the operation and project team.
- Validation of the functional analysis by the operation and project teams.
- Application development using the UNICOS-CPC package with the new functional analysis.
- A FAT (Factory Acceptance Test) period (in the lab) to eliminate programming errors with an additional period of virtual commissioning with a simulator of the new control system.
- A SAT (Site Acceptance Test) period, i.e. execute final commissioning on site.

CONTROL SYSTEM ARCHITECTURE

The original LHC water cooling plants used Schneider Premium PLCs programmed by PL7Pro software with distributed FIP I/O (Factory Instrumentation Protocol). The supervision system was based on the *Wizcon* SCADA. One of the main goals of the re-engineering exercise was to keep as much as possible the existing cabling and I/O interface and to focus the upgrade on the hardware and software of the control and supervision layers using the CERN standards for process control.

Therefore the PLC backplanes, FIP I/O cards and wiring have been kept while the CPU and Ethernet cards have been replaced by the latest Schneider hardware using Unity V7.0 as the programming development tool. Then, the SIEMENS WinCC OA (Open Architecture), the CERN SCADA standard, has been used for supervision. The SCADA resides in data servers running scientific linux as operating system. Those multicore machines, HP® *ProLiant* servers, both provide redundant power supplies and hard disks.

In total, the 21 new CPUs and 8 new WinCC OA projects (one per LHC point) have been setup in 2 data servers, see Figure 2, connected in a distributed mode.

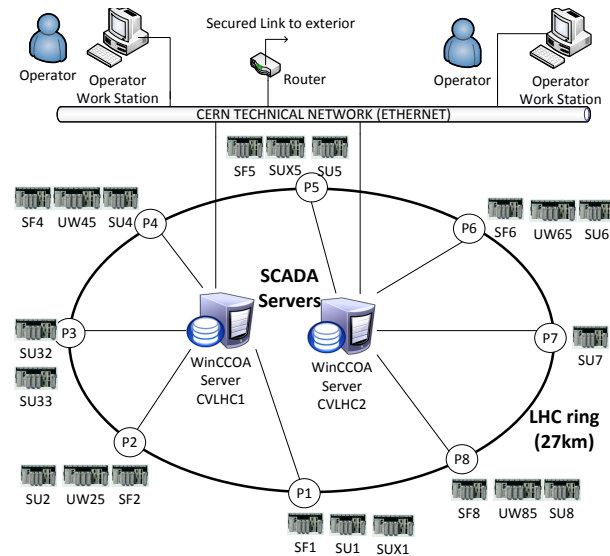

Figure 2: General control system architecture for LHC water cooling plants.

RE-ENGINEERING WITH UNICOS-CPC

The first main challenge was to identify all similarities in terms of functionality between all water cooling plants in order to provide generic code for common functionalities at different levels:

- Similarities on **actuator** functionality (e.g. in all SU, all distribution valves must be fully opened before the associated pump starting).
- Similarities on **process unit** functionality (e.g. in all SF, all the distribution circuits are stopped if at least one tower valve is not opened).
- Similarities on **interlocks** applied to actuators and/or process units (e.g. in all cooling plants, if a pump thermal protection is triggered, the pump is stopped and an operator explicit acknowledgement is needed to restart).

One of the main difficulties was that most of the installations were built at different periods by different manufacturers and contractors. Hence, this re-engineering represented an opportunity to homogenize as much as possible the controls of similar functionalities in agreement with the process experts. Nevertheless, process constraints on the different plants have requested some flexibility in several components.

Once the similarities were identified and agreed upon, controls engineers specified the **generic actuator interlocks** and wrote the **control logic templates** for common process units and actuators containing the generic PLC code. Figure 3 presents the complete data flow from the data gathering to the code deployment.

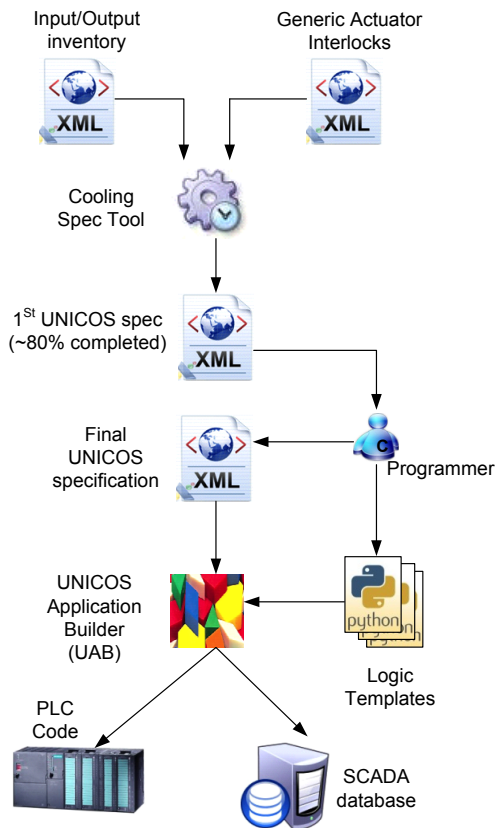

Figure 3: Data flow for code generation.

Cooling Spec Tool

The first automatic tool used is *Cooling Spec Tool* (CST). It allows controls engineers to automatically generate a first version of the UNICOS-CPC specification that describes all objects from a file containing a list of I/O and a list of generic actuator interlocks. In LHC cooling applications, CST generates around 80% of the final specification file (physical I/O, actuators and alarms and parameters attached to actuators). For instance, in a SU plant, CST generates 1860 object instances over a total of 2284 when the specification is completed. Then, the control engineer has to complete the specification according to the application, for instance adding some specific alarms at the unit level which cannot be generated from the I/O inventory.

In the following step, **UNICOS Application Builder** (UAB), the standard UNICOS-CPC automatic code generator [3], is used to generate PLC program code and the supervision database. **Control logic templates** allow controls engineers to write the PLC program code once; with parameterization, this code can be automatically adapted to multiple water cooling plant PLCs. The variability between several systems is then managed using user parameters in the specification file. As a quantitative example, SF control programs contain 60 different logic templates generating around 900 PLC functions over the 6 SF plants around the LHC.

VIRTUAL COMMISSIONING

Due to the criticality of these cooling plants, the commissioning time allowed for these re-engineering activities is particularly short (around 3 weeks). It is therefore primordial to check and validate the new control applications as much as possible before deploying on site.

Virtual commissioning allows controls engineers and process experts to test and debug almost all the PLC applications on simulation platforms. Clear advantages of virtual commissioning are that the PLC code is of higher quality and the risk of production problems, once the final control is deployed, is minimized resulting in increased plant availability.

Once the simulation test bench is ready, the checks are performed during 2 weeks; debugging and validating functionalities as much as possible in the PLC programs before the real commissioning on site. Therefore the SAT period is reduced and process harmful behaviours can be avoided.

Static Simulation

Static simulations are used when the control programs can be easily validated by simulating the main regulation loops and actuator feedbacks. For **SU** and **UW** water plants, where the dynamic behaviour is not important to validate control applications, this simulation is performed inside the PLC with additional dedicated PLC functions generated from information contained in the UNICOS-CPC specification file. These functions perform several simulation tasks:

- Some Digital Input signals are masked to avoid interlocks (e.g. presence of 400V power supply)
- Actuator feedbacks are simulated using the actuator orders with the addition of appropriate delays.
- Measured value of a Proportional-Integral (PI) controller are simulated with a first order transfer function in such a way that the controller set-point is reached for a PI output equal to 70% of its full range. Moreover, the time constant of the transfer function is set at 30 sec allowing programmers to test all regulation loops within an acceptable timescale.

Although the method is invasive because it uses the same platform (PLC) as the deployed control system, it is still very useful in terms of basic validation and simple control behaviour. It significantly simplifies the job of the controls engineer who does not need to manually simulate these actions, and can concentrate on testing the requirements detailed in the Functional Analysis. Moreover, this static simulation is very fast to setup using UNICOS-CPC tools (about one hour of work).

Dynamic Simulation

Dynamic simulations are used when the control programs must be checked in a more realistic way and where the process behaviour must be respected in terms of transients and amplitude. This is the case of **SF** water

plants where the flow dynamics play an important role in the refrigeration process.

The idea of these dynamic simulations is to develop a model of the process based on the physical equations driving the different process values (fluid mechanics, thermodynamics, etc.). This model of the process reads the actuator orders computed by PLC and then sends back all sensor information to the PLC in real-time (Figure 4).

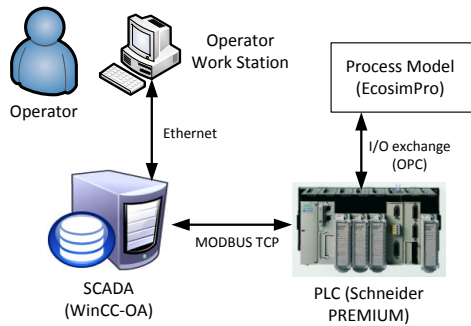

Figure 4: Dynamic simulation architecture.

Based on the experience of our team on dynamic process simulation of cryogenic systems, coupled with UNICOS-based control systems [4], a modelling library for water cooling plants has been developed under the multipurpose modelling and simulation tool EcosimPro®. The main water cooling components have been modelled (pumps, valves, pipes, cooling towers, etc.) to provide a complete dynamic model for any water cooling plant of LHC. Then, these process models are directly linked to the PLC via an OPC (OLE for Process Control) communication overriding the real inputs and outputs of the PLC.

RESULTS AND PERSPECTIVES

Today, 7 out of 20 PLCs have been reengineered in agreement with the project schedule. The upgrade will be completed mid-2014 before the LHC resumes operation at the end of 2014. The complete project for the control re-engineering will cost a total of 6.5 man-years (3.5 man-

years for controls and 3 man-years for the process analysis and validation).

Each commissioning period (SAT) takes around 3 weeks as expected thanks to the virtual commissioning. The re-engineered LHC cooling plants are now equipped with a standard UNICOS-CPC approach allowing a coherent control and providing the same interfaces and operation principles as the control system for the LHC cryogenics plants.

After this experience, the upgrade of the complete ventilation for LHC is planned. It will follow the same strategy and will be carried out during LS2, the second Long Shutdown in 2018. A “Ventilation Spec Tool” already exists to facilitate the generation of the UNICOS specification; dynamic models for ventilation systems are currently being validated in order to achieve virtual commissioning for HVAC systems.

ACKNOWLEDGEMENTS

We would like to thank the CERN Cooling and Ventilation (EN-CV) group and specially the operation and control teams, for their participation in capturing requirements and during the commissioning phase making this project a success. We would also like to thank the members of the UNICOS development teams in the CERN Engineering Industrial Controls (EN-ICE) group.

REFERENCES

- [1] D. Willeman, E. Blanco, B. Bradu, J. Ortola, “UNICOS-CPC new domains of applications: Vacuum and Cooling & Ventilation”, ICALEPCS’11, Grenoble, October 2011.
- [2] IEC 61512-1 or ANSI/ISA S88. Batch Control - Part 1: Models and terminology. 1995.
- [3] B. Fernandez et al., UNICOS-CPC6: Automated code generation for process control applications” ICALEPCS’11, Grenoble, October 2011.
- [4] Ph. Gayet and B. Bradu “PROCOS: a real time simulator coupled to the control system”, ICALEPCS’09, Kobe, October 2009.