

## FAST WIRE SCANNER UPGRADE FOR LCLS

J. M. D'Ewart<sup>#</sup>, M. Campell, P. Krejcik, H. Loos, K. Luchini, SLAC, Menlo Park, CA 94025, USA

### Abstract

Wire scanners are a main diagnostic tool for transverse beam size and emittance measurements at LCLS. The original SLAC wire scanners were not optimized for speed (taking minutes to scan), and can't perform at the desired level of position resolution necessary for measuring LCLS' small beam size. A new fast wire scanner, based on a dc linear servo motor, has been designed and installed in the LCLS. The new fast wire scanner has several advantages over the original wire scanner: scan times are reduced from minutes to seconds while minimizing wire vibrations. Rather than counting open-loop step pulses, the new fast wire scanner uses real time position capture for beam synchronous sampling of the wire position, enhancing beam profile accuracy.

### INTRODUCTION

The primary purpose of the wire scanner system is to provide a high resolution measurement of electron beam profile averaged over many shots. Profile measurements can also be used to determine transverse beam emittance.

The LCLS wire scanner system had been based on a drive system consisting of a stepper motor and a ball screw [1]. A 10X gear reducer was added to the system reducing wire vibration, but also reduced maximum wire speed [2]. A linear variable differential transformer (LVDT) was used to calibrate the drive system. The motion was operated in open-loop with no feedback about actual drive or wire position.

The design goals of the fast wire scanner are: reduce scan time from minutes to seconds, minimize vibration during the scan, improve position resolution of the wire scanner motion to  $1\mu\text{m}$  or better, incorporate real-time readback of the wire position through the data acquisition system, and to integrate the wire scanner into the LCLS EPICS control system [1].

The advent of the LCLS-II project at SLAC has also resulted in the need for a wire scanner that can move at speeds sufficient to prevent wire destruction during CW beam operation.

For the nominal LCLS-II beam parameters of 100 pC charge per bunch, a transverse emittance of  $0.5\mu\text{m}$ , and a bunch repetition rate of 0.6 MHz the minimum wire speed to avoid damage is calculated to be  $0.34\text{ms}^{-1}$ .

### FAST WIRE SCANNER

The fast wire scanner, shown in Fig. 1, uses an external actuator for linear motion. The drive system is based on the LinMot dc linear motor [3]. The wires are mounted on an interchangeable card that holds an x, y and u wire at  $45^\circ$  to the beam. A scan of all 3 wires can be done in a

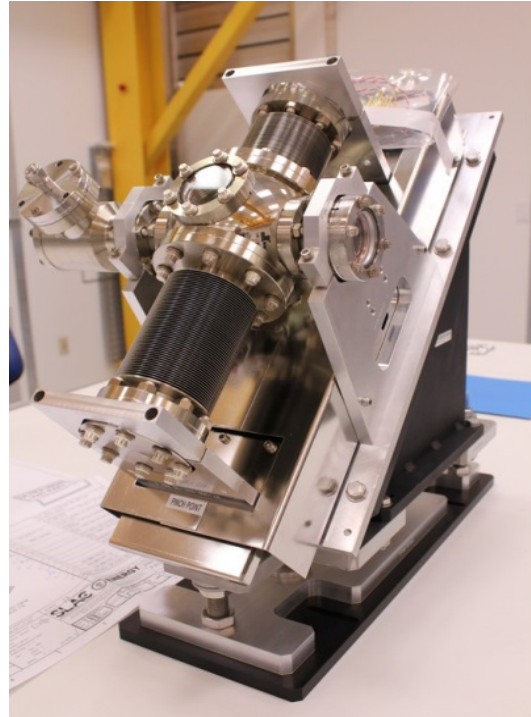

Figure 1: Wire scanner mounted at  $45^\circ$ .

single motion of the scanner before returning to the home position. An increment linear encoder is attached to the drive system and limit switches are used at the end of travel. The linear motor eliminates the discrete steps of a stepper motor and the linear encoder allows for closed-loop servo control.

### CONTROL SYSTEM

#### *Fast Wire Scanner Control System Architecture*

The fast wire scanner control system architecture is based on the original LCLS VME wire scanner architecture. The original LCLS wire scanners use a VME crate with a MVME 6100, MRF EVR, CAEN V965 QDC board, Isig high voltage power supply module, and Hytec IP8601 stepper motor controller. The fast wire scanner uses an additional Prodex MAXv VME motion controller for servo motion control. A MAXv breakout chassis and LinMot panel are also installed into the control rack to support the fast wire scanner. The MAXv breakout chassis separates each of the 8 axis control and I/O signals and interfaces to the LinMot panel. The LinMot panel houses the servo drive as well as drive and logic power supplies. This architecture allows a rolling upgrade for current LCLS wire scanners. A block

\*Work supported by the U.S. Department of Energy under contract number DE-AC02-76SF00515

<sup>#</sup>mdewart@SLAC.Stanford.EDU

diagram of the system is presented in Fig. 2.

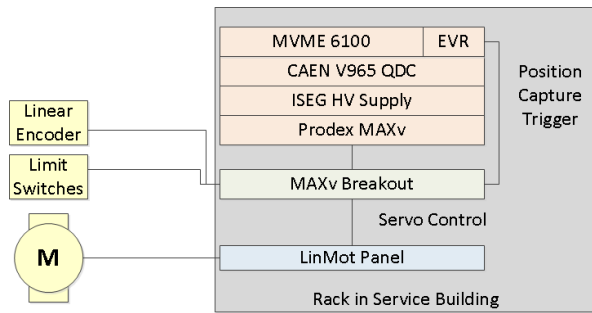

Figure 2: Fast Wire Scanner Control System Architecture.

### Motion Control

The motion control system consists of an EPICS IOC (MVME 6100 running RTEMS), a Prodex MAXv 8000 VME motion controller [4], and a LinMot B1100 servo drive. The MAXv provides control for up to 8 servo or stepper axes. In servo mode the MAXv provides PID servo control with a 122  $\mu$ s update rate. The MAXv is capable of custom, parabolic, S-curve and linear trajectory profiles. The MAXv servo signal is connected to the LinMot drive panel through the MAXv breakout chassis.

The LinMot panel, shown in Fig. 3 and Fig. 4, consists of a LinMot B1100 servo drive as well as a 72 VDC and 24 VDC power supplies. A Beckhoff BK9000, along with terminals KL1408 and KL2408, is used for digital I/O to interface with the LinMot B1100 servo drive. The digital outputs enable the drive and the digital inputs monitor status. The LinMot panel interfaces to the LinMot linear motor power and feedback signals and the MAXv control signals.

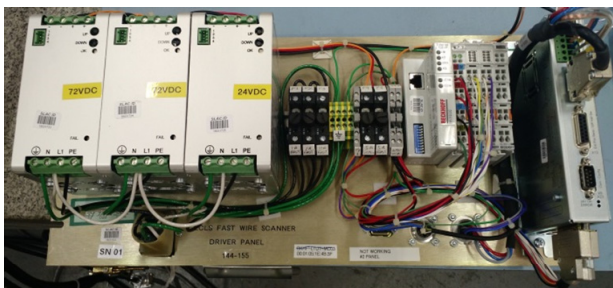

Figure 3: LinMot Panel, Front View.



Figure 4: LinMot Panel, Rear View.

### Encoder Processing

An incremental quadrature linear encoder is attached to the linear slide of the LinMot drive system. The linear encoder provides 1  $\mu$ m position resolution. The fast wire scanner system uses the real-time position capture feature of the MAXv. An EVR trigger is used to trigger a beam synchronous position capture event. The captured position data includes the axis, encoder position, positive and negative edge I/O bits, and home events [2]. The captured data is put in a ring buffer in VME shared memory and processed by the EPICS IOC. The position data is then processed by the beam synchronous acquisition (BSA) facility.

### Homing Procedure

Homing is performed to ensure a consistent reference position subsequent to each power-up. The 45° install angle means to motor rests on the lower hard stop when no power is applied. The homing procedure is then as follows:

1. Power on motor
2. Move just off of hard stop
3. Move toward negative hard stop
4. Detect hard stop based on demanded torque and position error
5. Set known position on hard stop

### Beam Synchronous Position Capture

The fast wire scanner uses the real-time position capture feature of the Prodex MAXv. An EVR trigger is used to trigger a beam synchronous position capture event. The captured position data includes the axis, encoder position, positive and negative edge I/O bits, and home events [4]. The captured data is put in a ring buffer in VME shared memory and processed by the EPICS IOC. The synchronously acquired position data is processed by a high level Matlab application to calculate beam profiles and transverse emittance.

### Scan Trajectory

A high level Matlab application is used to initiate a scan. The wire scan application selects which of the three wires to scan and the appropriate scan speed based on beam rate. The wire scanner moves at max speed between wires and at the appropriate scan speed  $\pm$  2 mm of the nominal wire position. A full S-curve trajectory is used for the motion. An S-curve trajectory allows for smoother wire trajectory by setting jerk, the derivative of acceleration, constant. An ideal wire scan trajectory, covering all three wires, is shown in Fig. 5. A snapshot of the high level graphical user interface is shown in Fig. 6, along with x, y and u scan data.

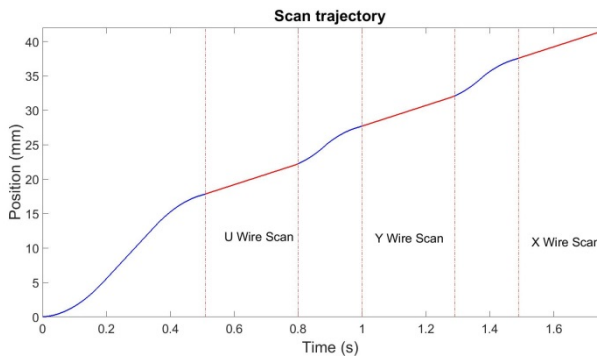

Figure 5: Ideal wire scan trajectory.

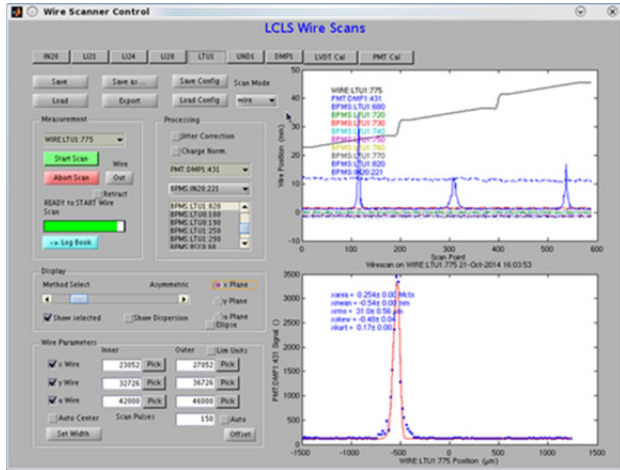

Figure 6: Wire scan graphical user interface showing x, y and u wire scan signals as well as motor position (top right) and individual wire scan profile (bottom right).

## CONCLUSION

We have designed a new fast wire scanner based on a LinMot dc linear motor. The control system is designed to be backward compatible and allow for rolling upgrade of the LCLS wire scanners. Real-time position capture is used to beam synchronously acquire wire position. Three new fast wire scanners have been installed in the LCLS to date. The remaining slow wire scanners will be upgraded in a rolling fashion throughout the LCLS.

## REFERENCES

- [1] M.C. Ross, et. Al, "Wire Scanners for Beam Size and Emittance Measurement at the SLC", Proceedings of the 1991 IEEE Particle Accelerator Conference, p. 1201, May 1991.
- [2] J. Frisch et al. "Beam Measurements at LCLS", SLAC-PUB-15018.
- [3] P. Krejcik et al, "Evaluation of New Fast Wire Scanner Designs for the LCLS", BIW2012, Newport News VA, USA.
- [4] <http://www.omsinmotion.com/>