

REUSABLE PATIENT SAFETY SYSTEM FRAMEWORK FOR THE PROTON THERAPY CENTRE AT PSI

P. Fernandez Carmona, M. Eichin, M. Grossmann, E. Johansen, A. Mayor, H.A. Regele
PSI, Villigen, Switzerland

Abstract

A new gantry for cancer treatment is being installed at the Proton Therapy Centre in the Paul Scherrer Institut (PSI), where already two gantries and a fix line operate. A protection system is required to ensure the safety of patients, requiring stricter redundancy, verification and quality assurance measures than other accelerators. It supervises the Therapy System, sensors, monitors and operator interface and can actuate magnets and beam blockers. We built a reusable framework to increase the maintainability of the system using the commercial IFC1210 VME controller, developed for other PSI facilities. It features a FPGA implementing all the safety logic and two processors, one dedicated to debugging and the other to integrating in the facility's EPICS environment. The framework permitted us to reduce the design and test time by an estimated 40% thanks to a modular approach. It will also allow a future renovation of other areas with minimum effort. Additionally it provides built-in diagnostics such as time measurement statistics, interlock analysis and internal visibility. The automation of several tasks reduces the burden of QA in an environment with tight time constraints.

INTRODUCTION

The Paul Scherrer Institut (PSI) was a pioneer in the field of proton therapy for cancer treatment by being the first centre to implement spot scanning for dose delivery back in 1996. Nowadays there exist many centres using such technology and several vendors offering commercial products. In order to increase the number of patients being treated it was decided to buy a scanning gantry from Varian Medical Systems [1], while keeping research and development in the existing in-house engineered areas. The current facilities of the CPT consist of a fixed beam line for eye cancer treatment, operating clinically since 2010, and Gantries 1 and 2 operating since 1996 and 2013 respectively [2] - [3]. The beam is provided by a dedicated 250 MeV cyclotron from the company Varian Medical Systems.

There are several systems required to allow for a safe and accurate delivery of the prescribed dose to the patient. The most relevant ones are the Patient Safety System (PaSS), to prevent accidents and the Therapy Control System (TCS), to deliver dose and to verify the correctness of the delivery. Other systems working independently but interconnected are the Beam Tuning Verification System (BTVS), the Machine Control System (MCS), the Run Permit System (RPS) and the Main Patient Safety Switch and Controller (MPSSC). Finally there is a number of Dose and Beam Position Monitors

and a set of final elements such as a kicker magnet and beam blockers.

In order to integrate the commercial gantry in the existing facility it was necessary to develop two adapters: The TCS adapter interfaces the vendor specific control system commands (such as setting energy and beam current values) to the appropriate facility resources. The PaSS adapter autonomously takes care of preventing accidents, and also actuates some final elements on request of the gantry. Figure 1 shows an overview of all the systems to which the PaSS is connected.

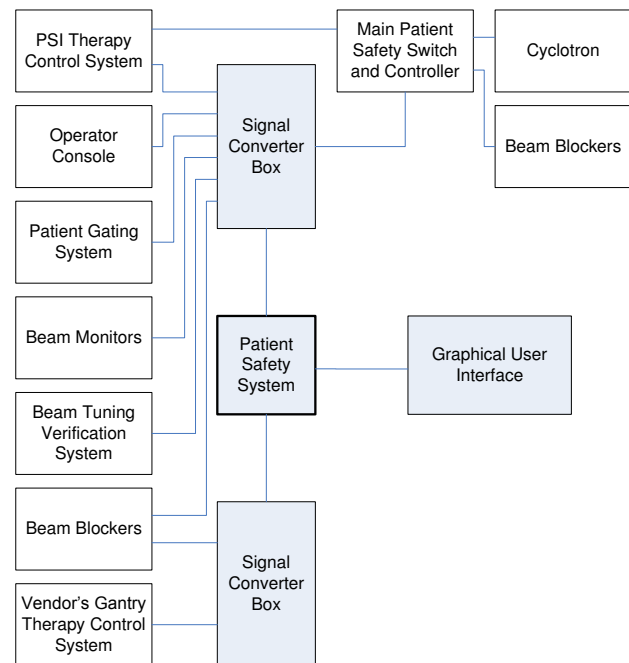

Figure 1: System overview of the integration of the new gantry's Patient Safety System.

This document describes in detail the new Patient Safety System developed for the installation of the new gantry. Also the experience of conceiving and designing it as a reusable framework, comparing it to previous designs is presented. Final tests for regulatory approval and clinical commissioning will take place during 2016 and patient treatment will start later in the year.

PATIENT SAFETY SYSTEM CONCEPT

The main goal of the patient irradiation for CPT is that each dose spot is delivered at the correct position and with the correct dose quantity. According to the International Commission on Radiation Units and Measurements (ICRU) [4], the aim in intensity modulated radiation therapy is to achieve an accuracy of 5% of the

total treatment dose. CPT adheres to the following safety goals [5]:

1. “No radiation accident”, considering a worst case local 5% dose excess.
2. “No error in the delivered dose”, avoiding dose distribution errors $\geq 2\%$ of the planned field dose.
3. “No error in dose position”, aiming at $\pm 1\text{mm}$ in lateral and depth direction
4. “Delivered dose and dose position must be known at all times” so irradiation can be interrupted and resumed safely.

The systems verifying that the previously defined goals are achieved are the Patient Safety System and the Therapy Control System, working independently. The PaSS collects information from several sensors and can actuate on certain final elements. Internally it has a hierarchical structure with ready signals and three levels of interlocks, from low to high severity as detailed in Table 1. Each level has a success supervision system and in case it fails, it escalates to the next level. All the logic inside PaSS is hard wired either in a Field Programmable Gate Array (FPGA) or with relays. This is required to maximize stability, predictability and minimize response time. Physically the interconnection lines are based on redundant three wire logic cables. All the information is sent together with its inverse using current loops that allow for detection of short or open circuits.

Table 1: Interlock system levels

Severity	Measures to prevent beam
ALOK	Close local beam blocker and activate deflector magnet
ATOT	Close main blockers, stop the proton acceleration in the cyclotron, plus all final elements actions of ALOK
ETOT	Switch off the cyclotron’s acceleration system, the ion source and all final elements actions of ALOK and ATOT

There are two modes of operation, one for therapy and one for experiments and development. The operation mode has to be consistently selected by a physical key at the operator console and by the TCS. Patients can only be treated in Therapy mode and in this mode the PaSS cannot be configured or altered. In Experiment mode it is possible to “bridge” certain interlock values or to overwrite some configuration parameters.

SYSTEM ARCHITECTURE

The main two constraints at the beginning of the project were restricted manpower and limited specifications. For that reason, a modular architecture was chosen, reusing as many elements as possible.

Hardware

The platform used was IFC1210, a commercial Versa Module Europa (VME) Input Output Controller (IOC)

from IOxOS Technologies [6]. It features a user programmable Virtex 6 FPGA and two PowerPC Central Unit Processors (CPU), both running SMP Linux. An EPICS kernel driver running on Linux implements the Ethernet-based Channel Access protocol and enables access to the registers inside the FPGA fabric. There are also two FPGA Mezzanine Card (FMC) bays, which were populated with Small Form-factor Pluggable (SFP) optical transceivers. The safety logic was implemented in the user FPGA and is totally autonomous after boot.

There were 98 interlock signals to be distributed to and from other systems in the facility. The connectivity was achieved with the Signal Converter Boxes, which are basically multiplexers. They are outsourced custom designed electronics, highly configurable with an Artix-7 FPGA, several SFP optical transceivers and ten generic plugin ports. The plugin ports are SMC mezzanine connectors to place application specific cards. In this way the platform has been defined to be flexible if the number or type of signals interfacing to the new gantry changed during the design phase. Already existing three wire logic plugins were used to interface with CPT systems, and three new types of plugins had to be developed according to specifications from Varian.

Firmware

IFC1210 provides a powerful firmware infrastructure with a Network on Chip (NoC) to which resources are connected. There are central resources such as FMC support or memory, and also user defined blocks. A user block was coded in VHDL language.

In order to increase reusability the design was divided into a platform independent PaSS Framework, and an application specific IFC1210 code. The framework consists of a package and generic building block definitions, such as timers, interlock trackers or input debounce elements.

The application specific code includes the safety logic, which is a Mealy state machine defining the configuration of the final elements based on present and past inputs, in addition to the specific memory interface, interconnection logic and instantiation of user configurable debug and visualization blocks.

Software

Many PaSS logic status and configuration variables are mapped via the on-board connectivity mesh in the IFC1210 to the EPICS driver and then exported through Ethernet to a local area network (LAN). A Graphical User Interface (GUI) was developed to set and get all 7000 published EPICS registers. It is organised in tabs; an overview is shown in Figure 2.

With the user interface one can visualise hardware and logical states of input, output and internal signals, display detailed information or bridge logical states of allowed signals. Also some statistic or debug information is displayed, like a chronological list of events, counters and timing statistics.

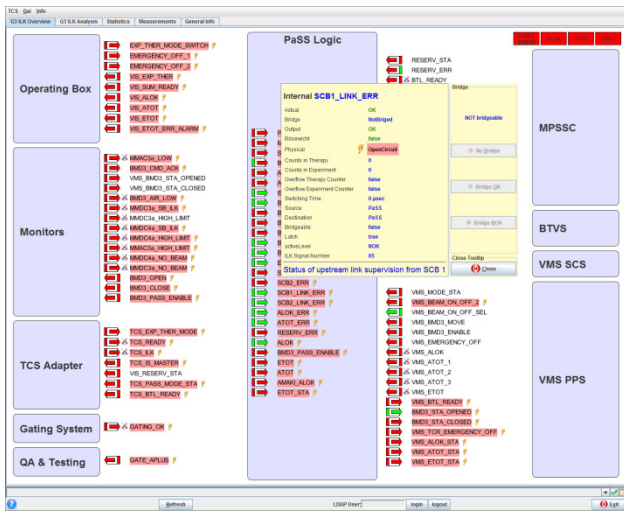

Figure 2: Interlock overview tab of PaSS GUI.

The GUI was programmed in Java using Apache Commons Logging, JavaX Mail, JCA and CosyLab CAJ libraries. It supports EPICS / ChannelAccess communication (directly with LPaSS IOC or through a ChannelAccess gateway), LDAP authentication (to authorize and log user actions), Mailing of important (user or program-triggered) actions and logging to files. Also the GUI is generic and gets all its application specific configuration parameters from an xml formatted file.

Automatic Generation of Configuration Files

A tool was created to generate a number of files based on a spreadsheet containing specific data of the project. It contains elements such as name and number of interlocks, bit width of the memory bus or desired extra visualization modules. It was programmed in Visual Basic and generates the following files: VHDL memory map block, interlock definition VHDL package, EPICS template with all registers and its location in memory, an xml file to configure the GUI and a memory definition header file for developing debug applications for the processor with Linux. In this way not only the system can be reconfigured fast after a modification, but it is highly portable to other treatment areas.

BUILT-IN FUNCTIONALITY

The powerful IFC1210 platform allowed placing extra functionality together with the basic safety logic in the design. This can be divided into the following groups.

General Infrastructure

Each input signal is automatically connected to a conditioning stage that takes care of debouncing in case of unstable sources like relays and decoding of the three wire logic to detect short circuits or broken cables. There is also a latch and bridge stages that modify the effective value of the signals according to the configuration package file. The physical, logic and effective values are all published via EPICS and available in the GUI. During

experiment mode only the operator will be able to bridge certain signals values. The switching time between valid states of the physical signals is measured, compared to a timeout threshold and published via EPICS. This data can detect deterioration of the opto-coupler devices used in the three wire logic current loops and damaged pieces can be replaced before actually failing.

Interlock Analysis

An absolute timer with a 1 μs resolution is running permanently on the IOC and when an interlock occurs a timestamp is generated. All the interlocks triggered after the event and last few before are logged. This information can be consulted in a table at the GUI which contains the exact time, name, source and destination of each interlock triggered. This table is cleared together with the interlock status after the cause has been solved and the TCS issues a clear command.

Statistics

For each defined input, output or internal line the PaSS Framework instantiates automatically a counter of events during therapy mode and another one during experiment mode. The GUI has a tab where this information, together with settling time of the inputs and minimum, maximum and average time measurements of reaction times of logic elements are displayed.

Measurements

Various elements of the patient safety logic require the measurement of a time or the supervision of an event before a given timeout. There are several of such blocks which can be used for Quality Assurance (QA) purposes, configurable from the GUI, as shown in Figure 3

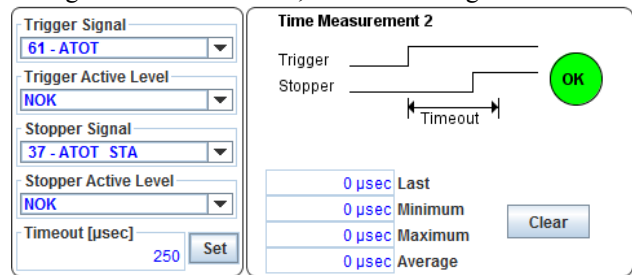

Figure 3: Configurable time measurement.

When the system is in experiment mode it is also possible to overwrite the timeout values of time measurements inside the safety logic itself. This can be used for example to verify during QA that an interlock is triggered if a certain element response is too slow. For the existing therapy areas this is time consuming, as it requires physically accessing the element and disconnecting it for the test. Now the test only requires configuring a few settings in PaSS using the GUI.

There is also a configurable number of interlock event counters which can be set to track a certain signal. This can be useful either for QA or to diagnose a problem when some error is occurring frequently.

VERIFICATION AND VALIDATION

The verification process of the PaSS for the new gantry has the following steps: risk analysis, design specification, implementation and test specification, each performed by different people.

All the verification and validation steps are based on previous experience with existing areas, following the procedure to obtain authorization for treating patients by the regulatory bodies for Gantry 2 [7]. As it was the case in previous systems, a test stand is being built. This is a piece of hardware that interfaces each interlock line, generating stimuli for the inputs and checking the output for correctness. Every time that a modification is introduced in a PaSS, the system must go through the extensive automated test process.

Finally, after installation the whole PaSS system including final elements undertakes an extensive QA program. These tests are typically measurements of reaction times of final elements and the correct response of the system to several injected errors. Thanks to the built-in measurement capabilities of the PaSS, many such tests can be automated without the need of probing the elements with an oscilloscope.

RESULTS

The introduction of the new PaSS brought several advantages. There are qualitative improvements like extra functionality and more accurate debug tools. There are also quantitative gains both in development time, compared to similar past projects and for easing facility operation.

From the point of view of QA there are time savings to be expected. The yearly test for PaSS and final elements takes approximately ten days for the three existing treatment areas. By automating the measurement of the reaction time of the final elements the QA time is expected to be reduced by three days. Also the failure of switching elements can be predicted and a replacement planned if a performance drift is observed.

Furthermore the availability of an interlock analyser window in the GUI with detailed and deterministic information of past events can result in a faster reaction time to problems by trained personnel. In older implementations, the interlock analysis was performed with an inverted tree of likely events but could not determine an original cause with absolute certainty. The new platform allows tracking individual occurrences of events with a resolution of 1 μ s. In addition, physicists are provided real time statistics of the frequency of each interlock, helping to detect defects. With that information they are able to make more analysis and better identify trends.

Finally, a careful project planning and work tracking allowed us to have a log of the effort spent in the development. This could be helpful as a work estimate for similar projects and also allows comparing the development time with previous PaSS developments. In Table 2 the number of full time equivalent days of work

in the new gantry safety system is shown. In row "SCB HW" there are the days of work reported by the subcontractor in the design of the Signal Converter Box.

Table 2: Approximate Development Days

System	Development	Documentation
IOC FW	105	40
GUI	9	1
SCB FW (PSI)	60	10
SCB HW	192	Not available

As a reference, work effort was compared to a similar development: the PaSS of CPT's fix beam line for eye tumour treatment. It was developed from scratch from 2008 to 2009 using FPGAs and EPICS. There are no accurate project management registers. The work effort, shown in Table 3, has been estimated from the date of the opening of the task in our repository to the date of commit of the documentation and source code. For the calculations it is assumed a dedication of 60% to the project and the vacation period is subtracted. Later commitments of bug fixes are excluded.

Table 3: Approximate Development Days

System	Development	Documentation
Old PaSS FW	310	55

From the comparison between the two projects it can be extracted that the use of a modular, reusable architecture based on ICF1210 IOC platform resulted in a time saving of approximately 40%.

CONCLUSION

A reusable, modular Patient Safety System was built to integrate a new commercial gantry in the existing infrastructure of the Proton Therapy System at PSI. By reusing existing technology it was possible to develop a highly sophisticated solution, highly customised, with restricted manpower and time. The separation of the design into generic and gantry specific parts would allow a fast deployment in other facilities, with only small adaptations being needed. Also the new detailed GUI, showing a deterministic log of events in case of an interlock can help the physicists save precious time identifying problems during patient treatment. Finally, by including built-in debug, visibility and measurement elements in the system it is possible to automate some QA tasks and to predict failures by ageing and deterioration of several components.

REFERENCES

- [1] Varian Medical Systems, [Online]. Available: <https://www.varian.com/oncology/solutions/proton-therapy>.

- [2] E. Pedroni et al, "Commissioning and use of the PSI spot scanning isocentric system for proton therapy," in *Proceedings of the 14th International Conference on Cyclotrons and their Applications*, Cape Town, South Africa, 1995.
- [3] E. Pedroni et al, "The 200-MeV proton therapy project at the Paul Scherrer Institute: Conceptual design and practical realization," *Med. Phys.*, no. 22, pp. 37-53, 1995.
- [4] International Commission on Radiation Units and Measurements, "Prescribing, Recording, and Reporting Intensity-Modulated Photon-Beam Therapy (IMRT)(ICRU Report 83)," 2010.
- [5] C. Bula, et al, "Report on Proton Therapy Safety Measures for Gantry 2," Internal report for regulatory body, Villigen, 2013.
- [6] IOxOS Technologies, [Online]. Available: <http://www.ioxos.ch/>.
- [7] O. Actis et al, "Gantry 2 Quality Assurance Manual," Internal report for regulatory body, Villigen, 2013.