

PROGRESS OF THE CONTROL SYSTEMS FOR THE ADS INJECTOR II*

Yuhui Guo, Haitao Liu, Jing Wang, Jiangbo Luo, Yongpeng Wang, Zhiyong He, Ting Liu
 Institute of Modern Physics, Chinese Academy of Sciences, Lanzhou, China

Abstract

This paper reports the progress of the control system for accelerator injector II used in China initiative accelerator driven sub-critical (ADS) facility. As a linear proton accelerator, injector II includes an ECR ion source, a low-energy beam transport line, a radio frequency quadrupole accelerator, a medium energy beam transport line, several cryomodules, and a diagnostics plate. Several subsystems in the control system have been discussed, such as a machine protection system, a timing system, and a data storage system. A three-layer control system has been developed for injector II. In the equipment layer, the low-level control with various industrial control cards, such as programmable logic controller and peripheral component interconnect (PCI), have been reported. In the middle layer, a redundant Gigabit Ethernet based on the Ethernet ring protection protocol has been used in the control network for injector II. In the operation layer, high-level application software has been developed for the beam commissioning and the operation of the accelerator. Finally, by using this control system, the proton beam commissioning for injector II in the control room has been mentioned.

INTRODUCTION

The Chinese Academy of Sciences initiated an accelerator driven sub-critical (ADS) program in 2011 under the frame of “Strategic Priority Research Program” for the objective of the safe disposal of nuclear waste as well as the potentials for advanced power generation [1]. In an ADS system (e.g. [2]-[3]), the high intensity beams from a proton accelerator bombard a heavy-metal spallation target located at the centre of a sub-critical reactor core to produce an intense neutron source. Then, the sub-critical reactor is driven by this intense external neutron source from the spallation target to achieve criticality.

In the China initiative ADS system, the proton accelerator consists of two injectors, each for the energy of 25 MeV, and a main accelerator which is designed for the energy of 250 MeV and the current of 10 mA. A demo facility for injector II has been manufactured in the Institute of Modern Physics of Chinese Academy of Science. In this paper, we report the control system for the demo facility of injector II.

* This work is supported by Strategic Priority Research Program of Chinese Academy of Sciences (XDA03021503)
 Corresponding author, Email: guoyuhui@impcas.ac.cn

THE OVERALL ARCHITECTURE OF CONTROL SYSTEM

Injector II in the China ADS system includes an ECR ion source, a low-energy beam transport line (LEBT), a radio frequency quadrupole accelerator (RFQ), a medium energy beam transport line (MEBT), 4 cryomodules and a diagnostics plate (Dplate). Each cryomodule consists of 6 superconducting Half Wave Resonators (HWR) cavities, 6 superconducting solenoids, and 5 beam position monitors (BPM). The main responsibility of the control system for injector II is to operate the accelerator injector II in the normal and harmonious fashion, and to monitor various parameters during the operation of the accelerator. The stability, reliability and ease of use are the main issues while designing the control system for injector II. Based on the Epics system architecture, a general three-layer control system is constructed for the ADS injector II [4].

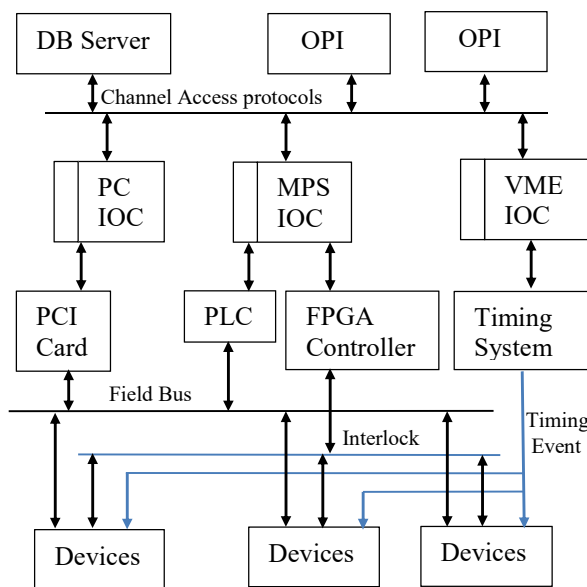

Figure 1: Overall structure of control system for injector II.

As shown in Fig. 1, at the top layer there is the OPI and DB server layer. It accesses two low-level machines for interfacing Epics IOC and the field devices by the intranet. At the same time, machine protection system and timing system will be built on the network of real-time control system with optical fiber. Based on the technology of FPGA and PCI bus, fast interlock controller can protect the critical equipment components from damage. The remote control and parameter setting for the field devices is implemented by the PCI cards and the PLC system.

Copyright © 2015 CC-BY-3.0 and by the respective authors

CONTROL NETWORK

A communication network is the backbone of the networked control systems. The industrial Ethernet switch is used to build the high reliability control network according to the different requests of reliability and data bandwidth. The commercial Ethernet switch is adopted to get the high bandwidth data network. Although industrial Ethernet and commercial Ethernet are designed based on the same standards, they have different working environment requests. The data is transferred by the Ethernet so that the staff can get the operational parameters and states from the central control house, laboratory and even the office. The network that building by industrial Ethernet switch is required to work steady under the extreme conditions, such as high temperature, electromagnetic interference. Thus the critical control equipment and interlocking protection devices is constituted by the industrial Ethernet switch.

Reliability, security, ease of use, and availability are the main issues while choosing the communication type. In order to improve the reliability of industrial Ethernet, various Ethernet redundancy methods based on Ethernet ring protection have been used. The Ethernet ring protection network builds a logical ring topology while maintaining a loop-free forwarding mechanism by logically blocking a link port in the ring, referred to as Ring Protection Link (RPL). Once a link fails, the vertices adjacent to the failure block the failed link, and the RPL is unblocked.

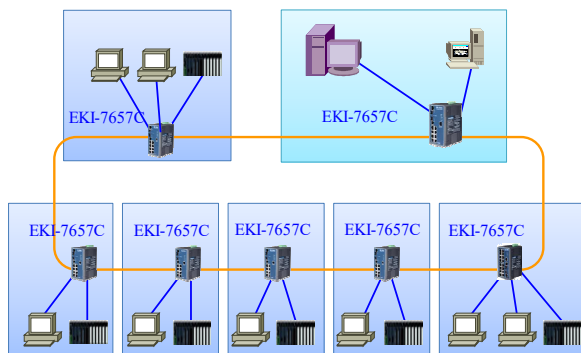

Figure 2: Redundant Gigabit Ethernet used for injector II.

Figure 2 shows the topological diagram of the Redundant Gigabit Ethernet used in the control system for injector II. In order to improve the reliability of the network, 7 EKI-7657C switches produced by Advantech company (<http://www.advantech.com/>) are used to build a X-Ring Pro that was developed by Advantech. The EKI-7657C supports seven Fast Ethernet ports and three Gigabit combo ports with 2x Digital Input and Digital Output ports. To create reliability in the network, the EKI-7657C comes equipped with a proprietary redundant network protocol, which provides users with an easy way to establish a redundant Ethernet network with ultra high-speed recovery time less than 20 ms. Furthermore, the EKI-7657C also supports many advanced network standards to optimize

network performance, ease maintenance issues, and secure network safety.

The X-Ring protocol can help the network system recover from network connection failure within 10 ms or less and make the network system more reliable. The X-Ring algorithm is similar to Spanning Tree Protocol (STP) and Rapid STP (RSTP) algorithm but its recovery time is less than STP/RSTP. X-Ring protocol maintains a loop-free forwarding mechanism by logically blocking a link port in the ring, referred to as X-Ring backup path, e.g. the leftmost link in Fig. 2. Once a link fails, the vertices adjacent to the failure block the failed link, and the backup path is unblocked.

TIMING SYSTEM

The main function of timing system is to provide synchronizing function for the different accelerator modules and devices with synchronous requirement. When ADS injector II is running in pulse mode, the synchronous trigger signal is needed for the microwave power and chopper power-supply of the ion source, low level control system and beam diagnostics device [5]. In order to produce desirable beam bunch, the timing system should provide low trigger signal to microwave power and chopper power-supply. The pulse width of the trigger signal can be adjusted from dozens milliseconds to several seconds. At the same time, the chopper power-supply's trigger signal, the RF power-supply's pulse giving signal and the beam diagnostics equipment's acquisition window signal should be synchronized by the timing system. The timing system in ADS injector II is provided by Shanghai institute of applied physics, Chinese Academy of Sciences.

MACHINE PROTECTION SYSTEM

A machine protection system (MPS) has been used to protect the machine's equipment from damage induced by beam losses and/or malfunctioning equipment. A set of diagnostic instrumentation installed throughout the injector, such as beam position monitors and wire scanners, will enable MPS to detect critical and non-nominal events. If a non-nominal event is detected, MPS will trigger an alarm, provide protection, or even initiate an emergency shutdown of beam.

Since the response time in the MPS is within several ms, the mainly control logic codes run on the dual redundant RFC460R 3TX controller. The acquisition and given for the control of the field facilities is achieved by the PLC IO modules which are distributed throughout the field that interconnected by PROFINET bus. When the main PLC goes down, the backup PLC will work immediately in several ms, so the time of system died is decreased and the system's reliability is improved [6]. The Machine Protection System manages the protection of vacuum chambers and magnets. In addition, a dedicated interlock system protects the RFQ, beam lines and half-wavelength resonator superconducting accelerator. It consists of one

slave PLC for each of the modulators and a master PLC that acquires cooling water and vacuum alarms from the accelerating sections.

Since the response time for the fast machine protection that is in the order of micro-seconds, the time of the fault detection and the time of the feedback control should be within 10 us [7]. As shown in Fig. 3, we have designed the fast controller for the fast machine protection system based on advanced FPGA chip and high-speed fiber optic network technology.

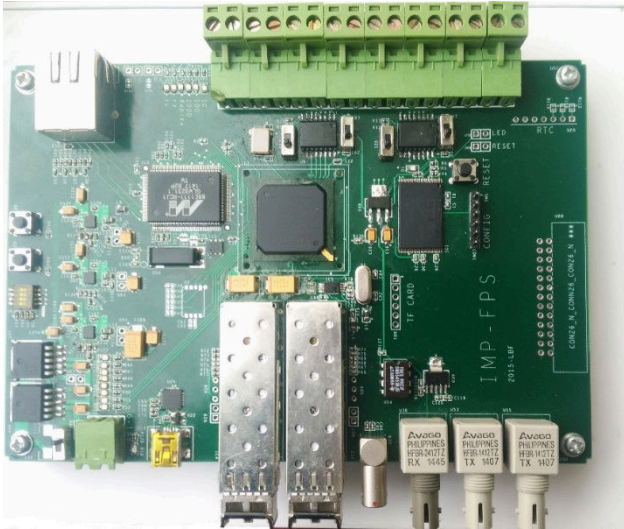

Figure 3: The fast machine protection controller based on FPGA and SFP.

The FPGA controller use Spartan 6 series products XC6SLX45T which was made by Xilinx Company [8]. The SFP optical modules with the rate of 1.25 G/s are adopted. These modules, which are used to interconnect different modules, have the same encapsulation though their rates are different so that they can be exchanged [9]. The control interface between facilities has two forms which is TTL signal and 5 M optical fiber receiver HFBR2412. The Machine Protection System can protect the costly facilities such as RFQ and superconducting cavity from high energy beam damage. It relies on various detectors (beam loss monitors, Low level system, ion chambers, dosimeters, current monitors, etc.) and inhibits the beam by control the chopper power-supply.

LOW LEVEL CONTROL

In the above-mentioned three-layer control system, the bottom-layer is the equipment layer where various sensors and actuators are used to control the equipment in injector II. The low-level control in the equipment layer means the industrial standard control modules for these sensors and actuators. For example, in the water-cooled system, the low-level control includes the sensors and actuators for the measurement of temperatures, the measurement and control of water flow speed, and the switch-on or switch-off of various valves. The low-level control is achieved

mainly by the following industrial control cards, programmable logic controller (PLC) and peripheral component interconnect (PCI).

The PLC used in the ion source system is Siemens S7 series 300 [10]. The inline controller series of Phoenix Contact has been adopted for the temperature detection of the beam line, the flow capacity of the cooling water and the chain protection system of the temperature. Profibus and Interbus are used to connect distributed peripherals to the CPUs, which communicate with the control system via Ethernet interfaces using the TCP/IP Send/Receive protocol and a dedicated Epics IOC server.

PCI card is mainly used on the motion control and the data acquiring systems. The PCI-1220 of Advantech Company is used to control the opening size of the air intake valve of the ion source, the position of the beam scraper, the motion of the Faraday cup. At the same time the PCI-9114 of Adlink Company is used to acquire data of the beam parameters for beam diagnostics devices, such as ACCT, DCCT. The PCI card can be debugged locally with an operator panel or remotely through a TCP/IP Ethernet interface and a dedicated Epics IOC server.

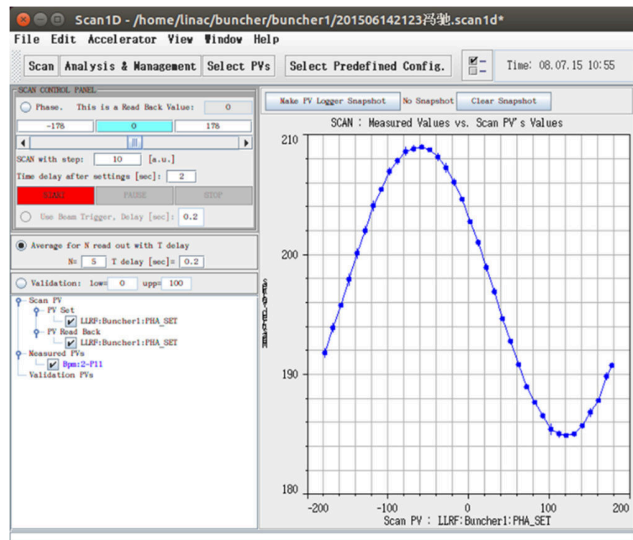

Figure 4: Phase scanning interface of buncher.

HIGH LEVEL SOFTWARE APPLICATION

In the top operation layer of the three-layer control system, various application software have been developed for the beam commissioning and the accelerator running, such as the application based on open XAL. As shown in Fig. 4, the phase scan program is used to determine the maximum acceleration phase of the accelerator. The cavity phase is scanned from 0 to 360 degree step by step. The BPM phase is recorded during scanning, whose maximum point means maximum acceleration. The x axis is cavity phase and the y axis is BPM phase in the curve. Since the curve is similar to sine wave, Fitting of the curve to sine wave will give out the phase and amplitude of the cavity for cavity setting.

The operation platforms in the central control room and subsystem's device control cabinet have been installed. The graphical user interface can display the parameters and the status during the operation of the injector. Figure 5 is the interface for the beam commissioning of injector II. The control system studio (CSS) is used to develop the operation interface which is based on JAVA. Compared with other tools, such as MEDM and EDM, the interface can be developed more practically by CSS. Thus, it has been used as a main OPI tool in the control system of injector II.

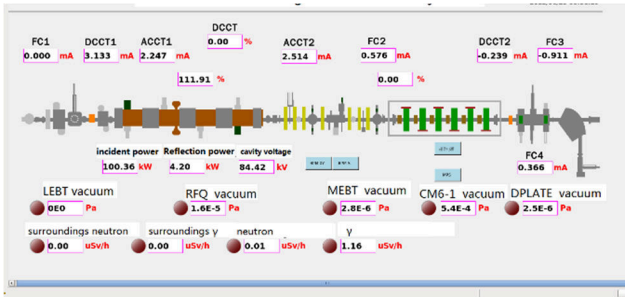

Figure 5: The interface for the beam commissioning of ADS injector II.

DATA STORAGE SYSTEM

With the development of the database and network technology, the information technology has been applied in the control system of accelerators. In the control system for injector II, the acquiring, managing and archiving of its data is an essential task. The main responsibility of the data storage system is to store multiple copies of all data and to be able to recall them on request. The stored data include the parameters of all devices, all information during the beam commissioning and the operation of the injector. The data storage system of ADS injector II can get data fast and provide friendly interface so that make it convenient to queries and displays the stored data.

The data storage system of ADS injector II is composed of two rack-mountable servers that are IBM System x3550 M3 services, and one storage system of IBM DS3500 storage system. The software for the data archived system has been developed with the Keep-alive and MySQL, in order to build a high-availability redundant database system. This system has dedicated to archive the beam related data and device status information [11].

CONCLUSION AND DISCUSSION

This paper has reported the progress of the control system for accelerator injector II used in the China ADS facility. Designed for the energy of 25 MeV, injector II consists of an ECR ion source, a LEBT line, a RFQ, a MEBT line, and 4 crymodules. By using this control system, the proton beam commissioning with the energy of 2.6 MeV has been finished in the control room in Nov. 2014, where the subsystems, ECR+LEBT+RFQ+ MEBT + a testing crymodule that consists of one superconducting

cavity, are tested. Furthermore, the proton beam commissioning with the energy of 5.3 MeV has been finished in the control room in June 2015, where the subsystems, ECR+LEBT+RFQ+ MEBT+ a crymodule that consists of 6 superconducting cavities, are tested. The beam commissioning with the maximum energy of 25 MeV will be taken in the near future.

REFERENCES

- [1] W.L.Zhan, H.S.Xu, et al., "Advanced fission energy program-ADS transmutation system", Bulletin of Chinese Academy of Sciences, p.375-381, Chinese (2012).
- [2] Yan Fang, Li Zhihui, Tang Jingyu, et al., "Preliminary physics design of China Accelerator Driven Sub-critical System main linac", High Power Laser and Particle beams, p.1783-1787, Chinese (2013).
- [3] Geng Huiping, Tang Jingyu, Li Zhihui, et al., "Design of the second medium energy beam transport line for China Accelerator Driven System", High Power Laser and Particle beams, p. 1005-1008, Chinese (2013).
- [4] Guo Yuhui, Yu Chunlei, Xu Weibin, et al., "Design of Software Platforms for Injector II Control System in ADS", Atomic Energy Science and Technology, p.29-32, Chinese (2014).
- [5] Xu Weibin, Guo Yuhui, Zheng Yawei, et al., "Design of synchronous controller for accelerator based on FPGA", High Power Laser and Particle beams, p.151011-151013, Chinese (2015).
- [6] Yu Chunlei, Guo Yuhui, He Yuan, et al., "Design of Control System for High Intensity Proton RFQ Based on Redundancy Technology", Atomic Energy Science and Technology, p.740-745, Chinese (2014).
- [7] Zheng Yawei, Xu Weibin, Luo Bin, et al., "Sub-control system based on PXIe Controller for high intensity proton accelerator", High Power Laser and Particle beams, p.951011-951015, Chinese (2014).
- [8] Xilinx DS162(v1.11), "Spartan-6 FPGA Data Sheet: DC and Switching Characteristics", January 2011; <http://www.xilinx.com>
- [9] Xilinx UG386(v2.2), "Spartan-6 FPGA GTP Transceivers", April 2010; <http://www.xilinx.com>.
- [10] Jiang Ziyun, Guo Yuhui, Liu Haitao, et al., "Control system of ion sources for injector of accelerator driven sub-critical system", High Power Laser and Particle beams, p.551021-551024, Chinese (2014).
- [11] Bao Xun, Li Chuan, Xuan Ke, et al., "Accelerator data collection system based on Channel Archiver", High Power Laser and Particle beams, p.589-592, Chinese (2008).