

# BPM BREAKDOWN POTENTIAL IN THE PEP-II B-FACTORY STORAGE RING COLLIDER

Stephen Weathersby, Alexander Novokhatski  
(SLAC National Accelerator Laboratory, Menlo Park, California)

## Abstract

High current B-Factory BPM designs incorporate a button type electrode which introduces a small gap between the button and the beam chamber. For achievable currents and bunch lengths, simulations indicate that electric potentials can be induced in this gap which are comparable to the breakdown voltage. This study characterizes beam induced voltages in the existing PEP-II storage ring collider BPM as a function of bunch length and beam current.

## INTRODUCTION

The SLAC PEP-II asymmetric B-factory storage ring collider nominally collides 1700 bunches of 3.0 A of 3.1 GeV positrons on 2.0 A of 8.0-10.1 GeV electrons. It consists of a low energy positron storage ring (LER) situated above a high energy electron storage ring (HER). The rings intersect at an interaction point (IP) within the BaBar detector sustaining a luminosity of  $1.2 \times 10^{34} \text{cm}^{-2}\text{s}^{-1}$  at the  $\Upsilon(4S)$  resonance. To monitor the beam position, hundreds of beam position monitors (BPMs) line the beam vacuum chamber. Each BPM consists of a round button electrode 15 mm in diameter which is mechanically press fitted to the 50 Ohm feed-through connector as shown in figure 1.

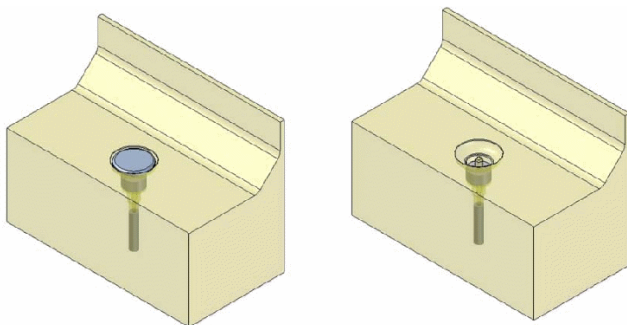

Figure 1: One quarter of the BPM geometry with and without a button. Chamber length is 9 cm. Button diameter is 15 mm.

While running at shortened bunch length (9 mm) some of the upper button electrodes heated up enough to fall off their mounts. The upper electrode fell onto the lower electrode as shown in Fig. 2 which not only shorted the underlying electrode but also became a large obstacle for the beam fields, increasing the current through the lower elec-

trode. This then melted the feed-through (Fig.3) causing a vacuum breach.



Figure 2: A button of an upper BPM fell off onto a lower button.



Figure 3: Melted feed-through of a lower button and the fallen upper button.

The origin of the heating is the wake field generated by an intense short bunch passing by the vacuum chamber discontinuity due to a BPM button. The effect of beam fields on a PEP-II BPM are examined[1]. Scattering parameter analysis reveals resonant behavior near the frequency of 7 GHz. Time domain simulations show that maximum electric fields in the BPM are located at the upbeam and downbeam extremes of the BPM button corresponding to an excited dipole resonant mode in the BPM environment. PEP-II has had a history of arcing and vacuum bursts caused by small geometric gaps in RF seals[3, 2]. It is natural to suspect that such small gap structures in the BPM design may cause the same problems. At a resonant condition when a

\* Work supported by Department of Energy Contract DE-AC02-76SF00515

BPM mode is a harmonic of a bunch spacing frequency the fields of many bunches will be summed. Shorter bunches and higher currents will also raise the maximum electric field at the BPM, which can approach the breakdown voltage taken to be roughly 30 kV/cm in copper.

## SCATTERING PARAMETER STUDIES

At LER currents of 2.4 Amperes with a bunch length of 0.8 cm, BPM buttons became hot enough to fall off their mounts near the IP region due to higher order mode (HOM) heating. In order to continue uninterrupted running, investigations were undertaken into the impact of missing buttons on machine performance. As shown in figure 1, the missing button leaves behind a stem onto which the button was mounted and the cavity which housed it. In order to quantify impedance presented to the beam by such a structure, a scattering parameter analysis is performed. Using electromagnetic solver MAFIA[4], a simulated wave of known power in the form of a lowest propagating vacuum chamber mode with a Gaussian frequency distribution is introduced into the geometries of figure 1. The vacuum chamber boundaries are matched to allow transmission of this mode in a smooth vacuum chamber without reflection. This mode with its radial electric field has similar physical characteristics to beam fields. Results indicate an impedance at 7 GHz for the intact button case as shown in in figure 4.

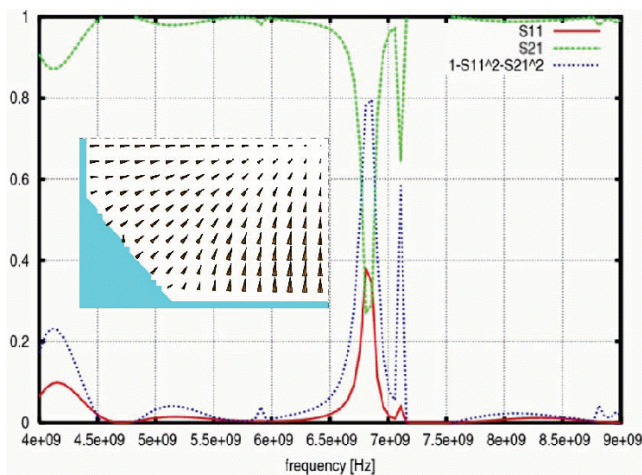

Figure 4: Fractional mode power transmitted  $s_{21}$ , reflected  $s_{11}$  and absorbed  $1 - s_{11}^2 - s_{21}^2$  for the IP BPM geometry of figure 1 with button. Inset shows mode electric fields.

The missing button scenario presents essentially no impedance in this frequency range, and machine running in this configuration presented no heating issues. The loss factor as computed with GdfidL[5] is lower with the missing button as shown in figure 5. With the missing button the BPM was still functional despite an attenuated signal.

**Lepton Accelerators and Colliders**

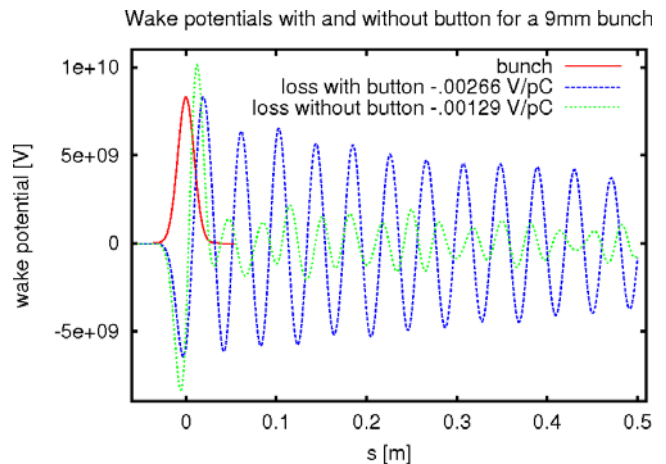

Figure 5: Wake potentials and loss factors for BPM with and without button for a 1 C 9mm bunch. Loss factor is lower without the button.

## SINGLE BUNCH SIMULATIONS

A single 1 C 6 mm long Gaussian bunch propagating on axis through the 0.09 m long vacuum chamber of figure 1 with the intact button excites fields in the vicinity of the BPM. A simulation performed with the GdfidL[5] time domain solver yields the electric field strength shown in figure 6 at a particular time after the passage of the bunch (0.4 ns). The maximum fields occur in the gap between the button and the vacuum chamber along the direction of the beam. For this case an electric field strength of  $4.59 \times 10^{13}$  V/m is generated. Normalized to a typical 14 nC PEP-II bunch charge this yields a maximum 6 kV/cm. As a function of time the maximum electric field peaks shortly after the bunch passes as shown in figure 7, reaching  $9 \times 10^{13}$  V/m for a 1C charge. This equates to 12.6 kV/cm for a 6 mm 14 nC PEP-II bunch.

The location of the maximum field changes with time. Figure 8 shows the position coordinates of the maximum field near the BPM as a function of time for a 6 mm Gaussian 1 C bunch. The largest coordinate variation is in  $z$  which is along the beam direction. The origin  $z=0$  corresponds to the BPM  $z$  position. The  $z$  variation reflects the movement of charge back and forth between the front and rear of the BPM with a frequency of 7 GHz. Smaller variations are present for the  $x$  and  $y$  coordinates. The maximum field location correlates with the smallest part of the gap between the button and the vacuum chamber. Figure 9 is a cross section view of the geometry which shows the smallest gap is interior to the BPM cavity.

## MULTI-BUNCH SIMULATIONS

To properly simulate B-factory operating conditions multiple bunches are required to traverse the vacuum chamber at the nominal bunch spacing of 4.2 ns, corresponding to two 476 MHz RF buckets. Initially a simulated Gaussian line charge of 1 C traverses the BPM vacuum chamber in

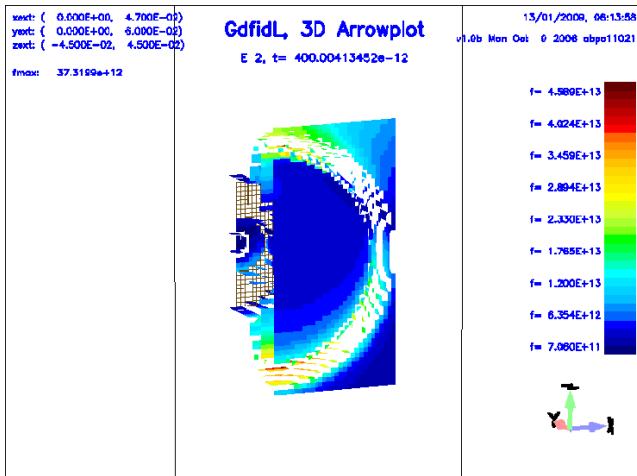

Figure 6: Electric field strength at the button as a function of time just after the arrival of one 9 mm 1 C bunch as computed with Gdfidl. Maximum field strength is  $4.59 \times 10^{13}$  V/m near the gap between the button and vacuum chamber interior to the button housing. Beam direction is along the  $z$ -axis.

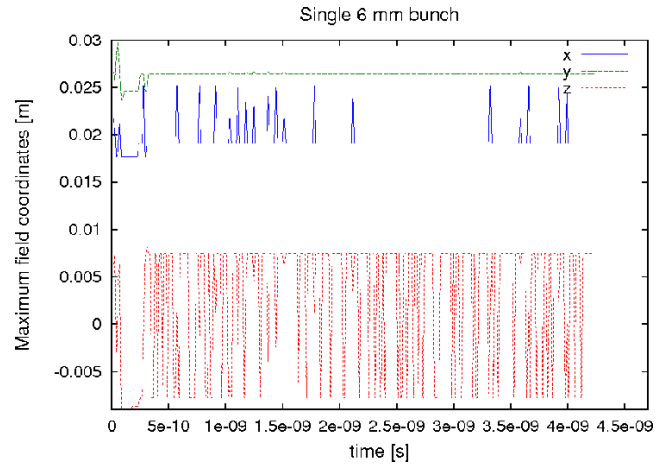

Figure 8: Coordinates of the maximum electric field strength in the vicinity of the BPM.  $z = 0$  is the position of the BPM along the  $z$ -axis beam direction. The maximum field position oscillates between the upbeam and downbeam parts of the button.

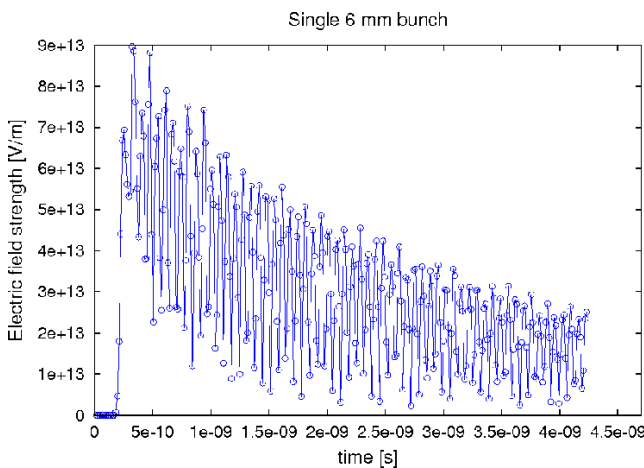

Figure 7: Maximum electric field strength at the BPM as a function of time for one 6 mm Gaussian 1 C bunch. The 14 GHz oscillation correlates with a 7 GHz half cycle of electric field maximum at two ends of the button. At  $t = 0$  the head of the bunch arrives at the upbeam end of the BPM chamber.

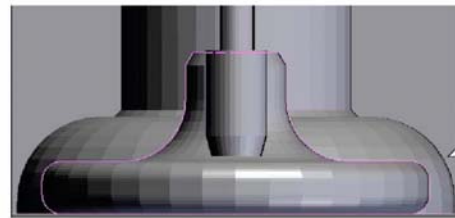

Figure 9: BPM cross sectional view. Maximum electric field strength at the BPM correlates with minimum gap spacing ( $\sim 1$  mm) between BPM button and vacuum chamber.

a time domain simulation. The resulting electric and magnetic fields are computed and saved at a time when a subsequent bunch is about to enter the computational domain. This saved field distribution forms the initial conditions for the next bunch simulation.

Figure 10 shows the maximum field strength at two particular times as a function of the number of 9 mm bunches. After four bunches have past, the field strengths appear to approach an equilibrium.

The maximum field at the BPM depends on the bunch frequency and bunch length. The PEP-II RF frequency is

**Lepton Accelerators and Colliders**

nominally 476 MHz and the nominal bunch spacing was 2 RF buckets or 4.2 ns. Changes in the RF frequency can move the bunch spacing closer to a BPM resonance. Figure 11 shows the maximum BPM electric field strength vs time for various RF frequencies and bunch lengths. The average field generated by four 9 mm bunches at various RF frequencies near the nominal 476 MHz is shown in figure 12.

A peak field of  $1.2 \times 10^{14}$  V/m for the shortest 4 mm 1C bunch at 1904 MHz translates to about 16.8 kV/cm at the nominal 14 nC bunch. Shorter bunches produce higher maximum electric fields as shown in figure 13 for the case of fixed 1904 MHz RF frequency.

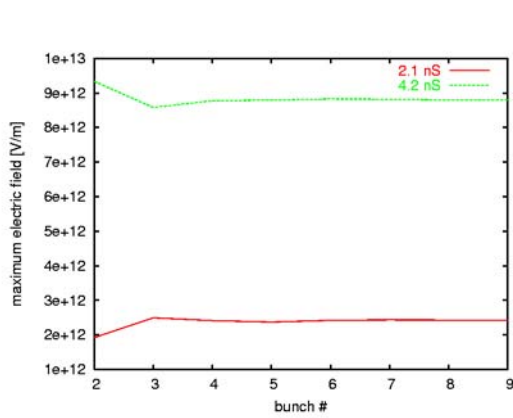

Figure 10: Maximum electric field at the button as a function of bunch number at two particular times for 1 C, 9 mm long Gaussian bunches. Solid trace is 2.1 ns, dashed trace is 4.2 ns. Fields have equilibrated after about 4 bunches.

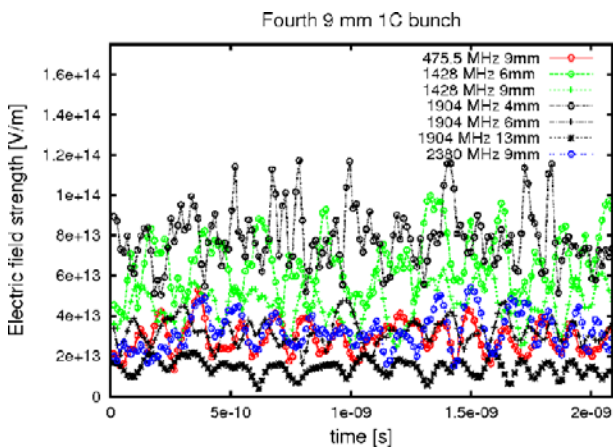

Figure 11: Maximum electric field at the button as a function of time during the passing of the fourth consecutive 1 C, at various RF frequencies and bunch lengths. Peak fields of  $1.2 \times 10^{14}$  V/m are achieved at 1904 MHz for the shortest bunch length of 4 mm.

### CONCLUSION

Fields from short bunches can approach the breakdown voltage for the PEP-II B-factory button style BPM at a certain bunch spacing and bunch current. The position of the maximum electric field is internal to the BPM at the smallest gap along the beam direction and oscillates at 7 GHz between the upbeam and downbeam surfaces. The nominal PEP-II 14 nC, 9 mm bunch length at 4.2 ns bunch spacing will generate up to 6 kV/cm after about 4 bunches which is a factor of 5 below the 30 kV/cm copper breakdown voltage.

### REFERENCES

[1] Numerical simulation of the PEP-II beam position monitor. N. Kurita, D. Martin, C.K. Ng, S. Smith, (SLAC) , T.

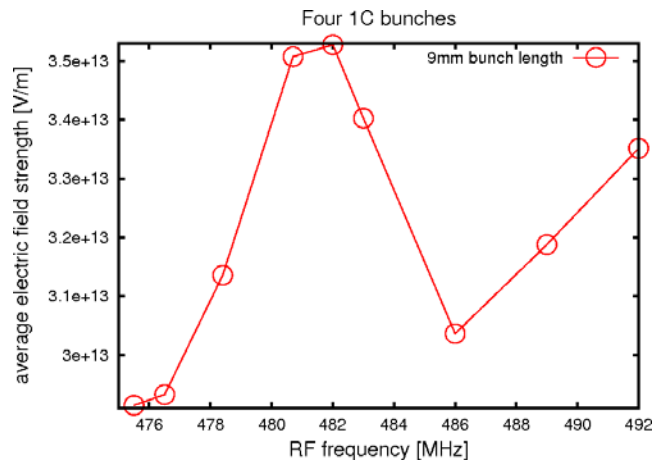

Figure 12: Average maximum electric field at the button as a function of frequency during the passing of the fourth consecutive 1 C 9mm bunch.

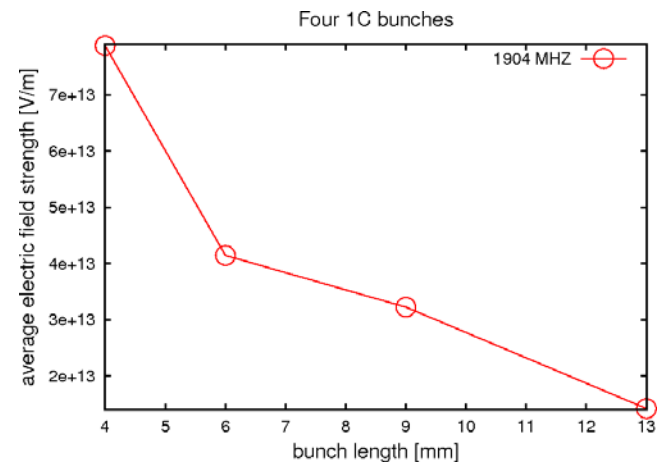

Figure 13: Average maximum electric field at the button as a function of bunch length during the passing of the fourth consecutive 1 C bunch for 1904 MHz RF frequency.

Weiland, (Darmstadt, Tech. Hochsch.) . SLAC-PUB-7006, SLAC-PUB-95-7006, Sep 1995. 10pp. Presented at International Workshop on Collective Effects and Impedance for B Factories, Tsukuba, Japan, 12-17 Jun 1995.

[2] A Novokhatski, J. Seeman, M. Sullivan (SLAC). "A Model of an Electrical Discharge in the Flange Contacts With Omega Seals at High Currents in PEP-II". In the Proceedings of 11th European Particle Accelerator Conference (EPAC 08), Magazzini del Cotone, Genoa, Italy, 23-27 Jun 2008, pp TUPP054.

[3] A. Novokhatski (SLAC). "HOM effects in vacuum system with short bunches". In the Proceedings of Particle Accelerator Conference (PAC 05), Knoxville, Tennessee, 16-20 May 2005, pp 289.

[4] The MAFIA collaboration "User Guide", CST GmbH, Darmstadt, Germany.

[5] <http://www.gdfidl.de>