

## FRONT ENDS AT ALBA

Jordi Marcos\*, Joel Pasquaud, Josep Campmany and Dieter Einfeld  
 CELLS, ALBA Synchrotron, Carretera BP-1413, Km 3.3, Cerdanyola, Spain

### Abstract

ALBA is a 3 GeV 3<sup>rd</sup> generation synchrotron radiation source built nearby Barcelona currently under commissioning phase. This paper describes the design and installation of the initial set of Front Ends that have been manufactured and assembled for day-one operation of the facility. This initial set includes 8 Front Ends devoted to transmit the photons generated by both Insertion Device or Bending Magnet sources to experimental Beamlines, and 2 additional Front Ends for electron beam-diagnostics purposes. The general layout of the Front Ends as well as the design and function of their main components is presented. Finally, we offer a brief summary of the production and installation timeline.

### INTRODUCTION

The 268.8 m long ALBA Storage Ring (SR) is based in an expanded DBA structure with four-fold symmetry, and a total of 16 cells [1]. Each quarter is composed of four basic cells, defining 1 long (8 m) straight section, 3 medium ones (4.2 m) and 2 short ones (2.2 m). Out of a total of 24 straight sections, 17 (12 medium + 3 long + 2 short) are available for the installation of Insertion Devices (IDs). Besides, 17 out of 32 bending magnets (BMs) have an associated beam port. Therefore there is a total of 34 beam ports where a Front End (FE) can be installed.

Phase I of ALBA project includes 7 Beamlines (BLs), six of them based on IDs [2] and one using a BM as a source (port #9). The set of Phase I IDs consists of two elliptical undulators (EUs, ports #24 and #29), two planar in-vacuum undulators (IVUs, ports #11 and #13), one conventional wiggler (MPW, permanent magnet hybrid technology, port #22), and one superconducting wiggler (SCW, port #4), all of them installed in medium straight sections. Apart from the 7 FEs required for Phase I BLs, during the assembly of ALBA SR it has also been installed: (a) an additional FE in beam port #2 equivalent to the ones with an in-vacuum undulator as a source, which can be used for test purposes and will remain available for a future BL; and (b) a pair of FEs in the BM beam ports immediately before and after the injection straight (#34 and #1), which are devoted to electron beam diagnostics [3] and that will be described elsewhere.

The relevant source characteristics, the radiated power (total power  $P_{tot}$  and peak power density  $(dP/d\Omega)_{max}$  at maximum e-beam current of 400 mA) and the user aperture requirements (horizontal  $\theta_H$  and vertical  $\theta_V$  angular openings) for Phase I FEs are summarised in Table 1.

Table 1: Source parameters for ALBA Phase I FEs at 3 GeV and 400 mA.

FE	Source	$B_{max}$	$K_{max}$	$P_{tot}$	$(dP/d\Omega)_{max}$	$\theta_H$	$\theta_V$
		[Tesla]		[kW]	[kW/mrad <sup>2</sup> ]	[mrad]	[mrad]
09	BM	1.42	—	0.097	0.25	±0.75	±0.6
24	EU62	0.88	5.1	2.65	7.5	±0.5	±0.5
29	EU71	0.93	6.2	3.28	7.6	±0.6	±0.6
22	MPW80	1.74	13.0	6.87	7.6	±0.94	±0.27
11	IVU21	0.81	1.6	2.95	25.8	±0.32	±0.19
13	IVU21	0.81	1.6	2.95	25.8	±0.32	±0.19
04	SCW31	2.1	6.1	20.09	47.5	±0.68	±0.18

### FRONT END LAYOUT

The layout of each individual FE has been adapted in order to take into account the geometrical constraints defined by the available distance from the SR isolation valve to the front wall of the tunnel and by the interference with adjacent elements (SR girders, RF cavities, cooling water pipes, etc). Besides, radiation absorbing elements have been designed in order to meet the aperture and power load requirements posed by both the characteristics of the photon sources and the needs of the BL users. At the same time, an effort has been made in order to keep a suitable degree of standardisation among the components of different FEs. With this aim a modular design approach has been adopted.

The distance from the SR isolation valve to the front wall for Phase I FEs is in the range within 6.9 m (FE29) and 9.1 m (FE24), but due to the proximity of the SR the space effectively available for the installation of FE components inside the tunnel is within 5.2 m and 7 m. The typical layout of Phase I FEs is illustrated in Fig. 1, with the following sequence of components going from the SR isolation valve to the BL: (1) 1<sup>st</sup> Fixed Mask, (2) X-ray Position Monitor (XBPM), (3) 2<sup>nd</sup> Fixed Mask, (4) Photon Shutter, (5) Protection Shutter, (6) Fast Closing Shutter (FCS), (7) Movable Masks, (8) Double Bremsstrahlung Shutter, (9) vacuum pipe through the front wall, and (10) Trigger Unit. The only exceptions to this scheme are: FE09 (BM source), which has neither (1) 1<sup>st</sup> Fixed Mask nor (5) Protection Shutter; and FE29, where due to space restrictions the (7) Movable Masks have been moved into the Optics Hutch of the BL, just after the Trigger Unit.

### FRONT END COMPONENTS

**(1) 1<sup>st</sup> Fixed Mask** A 1<sup>st</sup> Fixed Mask is installed in all FEs with an ID as a source in order to protect downstream FE components from dipole radiation. This element consists of a 39 mm-thick copper block with internal water

\*jmarcos@cells.es

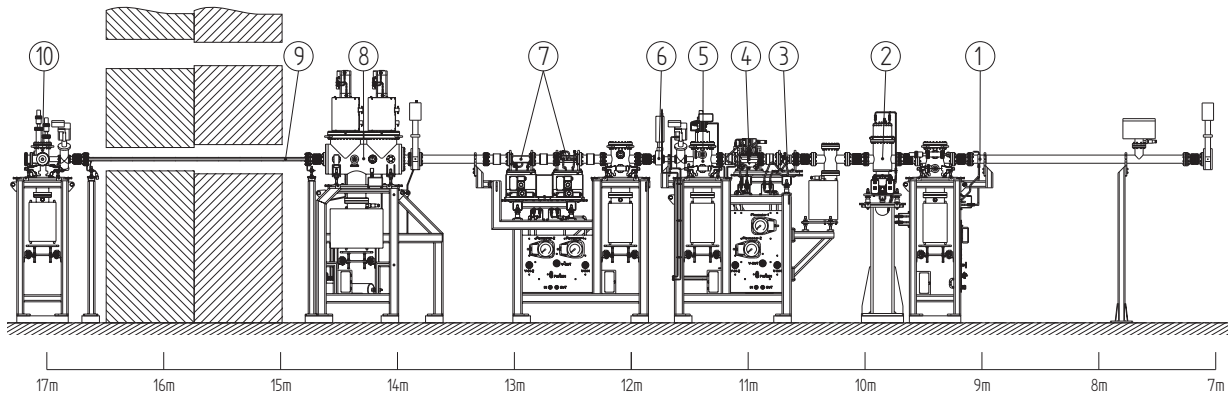

Figure 1: Layout of a typical FE at ALBA (FE13, source: in-vacuum undulator). Numbered elements are described in the text. Bottom scale indicates the distance from the source point.

cooling, which is integrated into the first vacuum pipe connecting the SR isolation valve and the first pumping chamber of the FE. The copper block has an aperture which allows the passage of the full ID radiation fan taking into account the maximum allowed mis-steering of the e-beam.

(2) **XBPM** Each FE is equipped with one XBPM in order to monitor the position of the photon beam at a distance of 7–10 m from the source point. Monitors have been produced according to the designs developed by K. Holldack from BESSY in collaboration with FMB [4]. Each XBPM makes use of four narrow negatively biased blades which intercept the edges of the photon beam distribution. The photoelectrical currents generated at each blade are measured using a low current monitor, and after being combined they allow an on-line determination of the horizontal and vertical position of the centre of the beam

Two different blade configurations have been employed depending on the characteristics of the source. In the case of BM sources (FE09), four copper blades in the so-called Staggered Pair Monitor (SPM) configuration have been used [5]. This configuration allows only to determine the vertical position of the beam, but as a counterpart it provides an internal calibration standard. In the case of ID sources, four tungsten blades arranged in a X-shape have been used [6], providing information for both horizontal and vertical planes. This configuration requires a proper calibration for each setting of the ID source. The size and geometry (distances and angles) of the tungsten blades have been adapted to the beam characteristics of each ID in order to optimise the sensitivity of the system.

(3) **2<sup>nd</sup> Fixed Mask** This element collimates the photon beam and defines the maximum beam size available to the users ( $\theta_H$  and  $\theta_V$  parameters in Table 1). By doing so, it removes the radiation that will not be used under any circumstance, and reduces the heat load to be handled by the Photon Shutter.

In all cases, 2<sup>nd</sup> Fixed Masks consist of an out-of-vacuum copper body (either OHFC or Glidcop®), depending on the case) with an internal rectangular aperture defined by four inclined surfaces. Depending on the amount

of power to be absorbed, different cooling schemes have been implemented. For small heat loads (< 0.5 kW, BM source and IVU sources), a single cooling loop drilled around the aperture has been used. For medium heat loads (within 0.5 and 4 kW, EU and conventional wiggler sources) it has been used a “spiral cooling” configuration (see Fig. 2), with a stainless steel cover (water box) brazed to the cylindrical body of the absorber, where a cooling channel in spiral has been machined. For higher heat loads (> 4 kW, SCW source) it has been used a “side cooling” configuration (see Fig. 2), with grooves machined next to each surface defining the aperture, and a cover with the appropriate dimensions closing the machined cavity.

(4) **Photon Shutter** The Photon Shutter is responsible for interrupting the photon beam when required, protecting all downstream components from synchrotron radiation. In the case of FE09 (BM source, less than 100 W of associated power), an in-vacuum pneumatically-actuated absorber has been used. The absorber consists of a water-cooled plate of OFHC copper forming an acute angle (30°) with respect to the incident beam. In the case of FEs with an ID as a source (between 1.5 and 13.5 kW), an out-of-vacuum design based on the high-power absorber from ESRF [7] has been used. In this design two brazed Glidcop® blocks define an internal aperture whose profile depends on its vertical position. When in open position, the aperture consists of two lateral straight surfaces that allow the passage of the full radiation fan as defined by the 2<sup>nd</sup> Fixed Mask. When in closed position, the two lateral surfaces are tapered and water-cooled according to the “side-cooling” scheme (recall Fig. 2), and stop completely the photon beam. The vertical stroke required in order to go from one position to the other is 16 mm, and the pneumatic actuator which drives the system takes ~ 200 msec to close it.

(5) **Protection Shutter** This element consists of a pneumatic cylinder and an in-vacuum 10 mm-thick copper plate. It does not have any water cooling and completely blocks the photon beam when in closed position. It is triggered together with the FCS and has a closing time of ~ 50 msec, thus protecting the FCS from synchrotron radi-

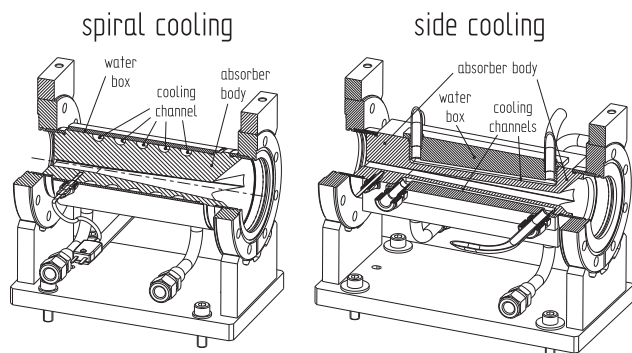

Figure 2: 2<sup>nd</sup> Fixed Masks for FE22 (left, conventional wiggler source) and FE04 (right, SCW source), illustrating “spiral” and “side” cooling schemes.

ation during the time lapse required by the Photon Shutter to close.

**(6) Fast Closing Shutter (FCS)** It is a Series 77 DN40 all-metal fast shutter from VAT [8] which closes in less than 10 msec when triggered. The vacuum gauges providing the trigger signal for the FCS are located in the Trigger Unit, which is installed in the Optics Hutch of the BL, thus protecting the SR against a vacuum failure in the BL.

**(7) Movable Masks** Movable Masks allow users to define the photon beam delivered to the BL. They consist of a pair of Glidcop® blocks, each one having a rectangular aperture with two tapered surfaces (left-top surfaces for mask#1 and right-bottom surfaces for mask#2) that intercept part of the photon beam. All inclined surfaces are water-cooled using the “side cooling” scheme (recall Fig. 2). Each mask is mounted on a motorised X-Y stage, and when combined the two masks delimit a rectangular cross-section aperture with customisable size and position within the maximum aperture defined by the 2<sup>nd</sup> Fixed Mask.

**(8) Double Bremsstrahlung Shutter** This radiation safety element comprises two pneumatically-actuated UHV-compatible tungsten-alloy blocks with a cross section of 120 mm × 120 mm and a thickness of 200 mm. The two blocks are driven simultaneous but independently due to redundancy reasons, and in combination with the Photon Shutter they grant a safe access of the users into the Optics Hutch of the BL during operation.

**(9) Vacuum pipe through front wall** This rectangular cross-section pipe, providing the connection between the accelerator tunnel and the Optics Hutch, has a standard length of 1.9 m and an internal opening of 41mm × 20mm for all FEs except #09, 24 and 29, which have a larger vertical aperture requirement (see  $\theta_V$  values in Table 1) and hence an enlarged opening of 41mm × 30mm.

**(10) Trigger Unit** The so-called Trigger Unit consists of a vacuum chamber where the two dedicated vacuum sensors that trigger the FCS are installed.

## 02 Synchrotron Light Sources and FELs

### A05 Synchrotron Radiation Facilities

## DESIGN CONSIDERATIONS

The design and validation of all power absorbing elements has been carried out in-house by means of Finite Element Analysis (FEA) using ANSYS 10.0. As a rule of thumb, the incidence angle of the radiation on the cooled surfaces of the absorbers has been decreased until reducing the maximum power density down to 10–15 W/mm<sup>2</sup>.

A cooling water velocity of 3 m/s has been considered in most of the cases, and it has been increased up to 4 m/s if required (only for the Movable Masks of FE04). The upper limits for the peak values of the different magnitudes considered within the FEA thermal analysis have been: (a) 100°C for the cooling water temperature; (b) 150°C for the temperature on the walls of the cooling channels; (c) 65–70 MPa stress and 0.1% strain in the case of OFHC copper absorber bodies; and (d) 250 MPa stress and 0.2% strain in the case of Glidcop® absorber bodies.

## CURRENT STATUS

The contract for the production of all Phase I FEs was awarded to FMB [4] on July 2007. The production spanned over 1 year: from March 2008 to February 2009. The installation was carried out using in-house resources, most of it in parallel with the installation of the SR sectors between May and October of 2009. The installation of the last components was completed on July 2010.

As per June 2011, BM (FE09) and out-of-vacuum ID (FE22, 24 and 29) FEs have been successfully commissioned for e-beam currents up to 20 mA. The commissioning of IVU (FE11 and 13) and SCW (FE04) FEs will take place on October 2011.

## ACKNOWLEDGEMENTS

Authors wish to acknowledge the assistance and involvement of J.C. Biasci from ESRF during all the phases of the design and production process. We would also like to thank FMB Berlin for the detailed design and manufacture of all the FE components, as well as K. Holldack from BESSY for the design of the XBPMs.

## REFERENCES

- [1] M. Muñoz, and D. Einfeld, PAC’05, Knoxville, May 2005, p. 3777 (2005).
- [2] J. Campmany *et al.*, EPAC’06, Edinburgh, June 2006, p. 3598 (2006).
- [3] U. Iriso *et al.*, DIPAC’07, Venice, May 2007, p. 27 (2007).
- [4] FMB Feinwerk- und Meßtechnik GmbH, Friedrich-Wöhler-Straße 2, Berlin, Germany, <http://www.fmb-berlin.de>
- [5] W.B. Peatman *et al.*, J. Synchrotron Rad. **5**, p. 639 (1998).
- [6] K. Holldack *et al.*, Nucl. Instr. and Meth. A **467–468**, p. 213 (2001).
- [7] J.C. Biasci *et al.*, J. Synchrotron Rad. **9**, p. 44 (2002).
- [8] VAT Vakuumventile AG, Seelistrasse 1, Haag, Switzerland, <http://www.vatvalves.com>