

# PROGRESS IN INSERTION DEVICES FOR TPS IN PHASE I

Cheng-Hsing Chang, C.S. Hwang, C. H. Chang, J.C. Huang and C. K. Yang  
NSRRC, Hsinchu 30076, Taiwan

## Abstract

Taiwan Photon Source (TPS) with beam energy 3 GeV and beam current 500 mA is a third-generation synchrotron radiation facility of medium energy. In the initial commissioning stage of TPS, the machine will be equipped with ten insertion devices (ID) and serve seven beamlines in phase I. Of these, three long straight sections configured as a double-minimum betay function lattice design with minimized beam influence of emittance are used for the installation of a pair of insertion devices in a straight section, two undulators of APPLE-II type and four in-vacuum undulators (IU), to produce great brilliance and coherent X-rays with great flux. The details of these insertion devices are explained herein.

## INTRODUCTION

At present the construction of TPS civil engineering is proceeding, with commissioning of the machine planned in 2013. The circumference of TPS is 518.4-m. It consists of 24 straight sections, including eighteen sections of length 7 m and six sections of length 12 m, to accommodate beam-injection devices, a SRF cavity, insertion devices and so on. To fulfil various experimental requirements in the first and early phases of TPS completion, one set of EPU46, two sets of EPU48 and seven sets of IU are arranged in seven district straight sections. Table 1 and Figure 1 explain the main parameters and scheme of these ID in phase I [1-2].

Table 1: Specifications of Insertion Devices Adopted for the TPS First Stage

| Ee /GeV              | EPU48 | IU22    | IU22 | EPU46 |          |
|----------------------|-------|---------|------|-------|----------|
|                      | 3     |         |      |       |          |
| photon energy /keV   | HP    | 0.4-1.5 | 5-20 | 5-20  | 0.45-1.5 |
|                      | VP    | 0.4-1.5 |      |       | 0.45-1.5 |
| current /A           | 0.5   | 0.5     | 0.5  | 0.5   |          |
| $\lambda$ /mm        | 48    | 22      | 22   | 46    |          |
| $N_{\text{period}}$  | 67    | 95      | 137  | 83    |          |
| $B_y$ /T             | 0.85  | 0.79    | 0.79 | 0.83  |          |
| $B_x$ /T             | 0.59  |         |      | 0.59  |          |
| $K_{y_{\text{max}}}$ | 3.81  | 1.54    | 1.54 | 3.57  |          |
| $K_{x_{\text{max}}}$ | 2.6   |         |      | 2.5   |          |
| $L$ /m               | 3.2   | 2       | 3    | 3.8   |          |
| gap /mm              | 13    | 6.5     | 6.5  | 13    |          |
| number of devices    | 2     | 2       | 5    | 1     |          |

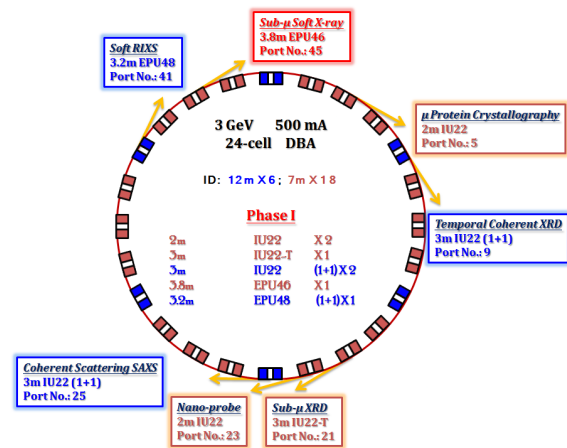

Figure 1: Distribution of insertion devices in phase I.

All insertion devices can be used to produce a spectrum of photon-energy domain 0.4-20 keV (shown in Figure 2) and with high brilliance and great flux. When placing two collinear undulators, an electrical phase shifter to tune the time delay of the electron beam would also be installed between the two ID as a function of the constructive interference of the light.

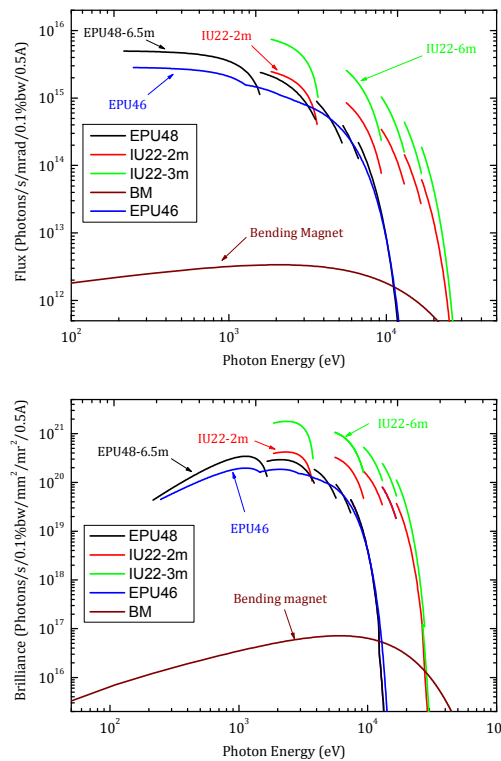

Figure 2: Spectral performance of insertion devices adopted at TPS.

## HELICAL UNDULATOR

To answer the desire of users for variously polarized light, the following undulators in APPLE-II type are planned to be established.

### EPU46

This equipment was designed, fabricated, and assembled by ADC and the performance of mechanical structure and magnetic field was improved and shimmed at NSRRC [3-4]. Figure 3 shows the overall construction of EPU46. Its mainframe is composed of heavy inertia H-section beams and aluminium plates. To bear an enormous magnetic force, a solid rectangular aluminium bar was selected as a back beam. Eight servomotors are installed in the device to adjust the gap and to vary the phasing mode; four govern the gap and the others govern the phase. To locate the machine, survey targets and three kinematic feet are applied for alignment.



Figure 3: Elliptical Polarized Undulator (EPU46) with period length 46 mm.

To achieve the field requirement, a neodymium iron boron magnet (NdFeB, N39UH) was decided to be adopted. Correction of the magnetic field of the undulator is under way.

### EPU48

The development of two sets of EPU48 including magnetic circuit design, engineering design, magnet module construction and field correction will be done in-house. Both EPU48 are arranged at the same section as shown in Figure 4. The EPU48 mechanical frame is fabricated by a domestic vendor. The engineering design of EPU48 is drawn in Figure 5. It consists of a cast mainframe, a welded base frame, two solid aluminium beams and so on. Some construction of key components was subjected to simulation and optimization with by 3D finite-element analysis code. The magnet is also made of NdFeB (NMX-S41EH). The manufacture of the magnets is nearly complete and shipment is being prepared [5].

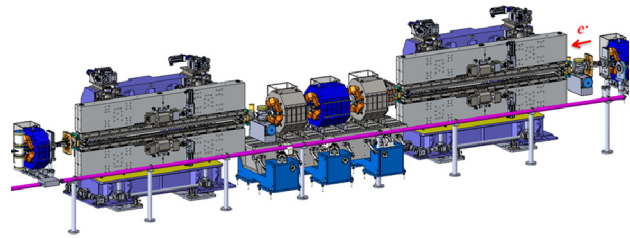

Figure 4: Two collinear EPU48.

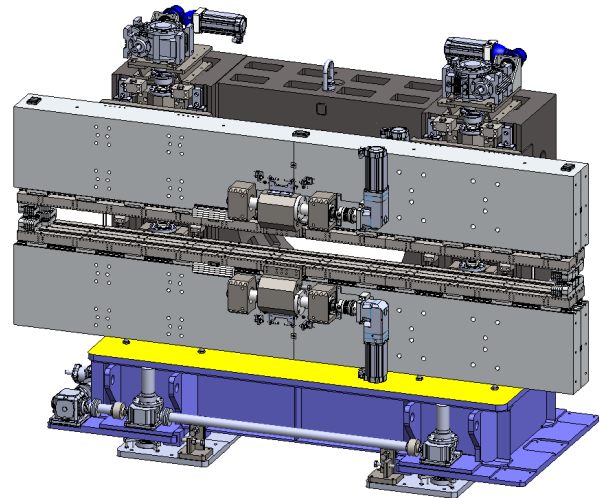

Figure 5: Elliptically Polarized Undulator with period length 48 mm.

The overall length of the magnet array is divided into many sections of magnetic modules. Magnetic modules are stacked from 2, 3, 5, 6, 7 or 9 magnetic blocks with keepers respectively. The purposes of this design are ease of access and pre-field correction. Figure 6 shows the field adjustment mechanism of an individual magnet in situ. To alter the vertical position of the magnet, turning the socket cap screw enables variation of the horizontal position of the wedge block; then the magnets can rise or fall. To vary the horizontal position of the magnet, a hollow-set screw is rotated.

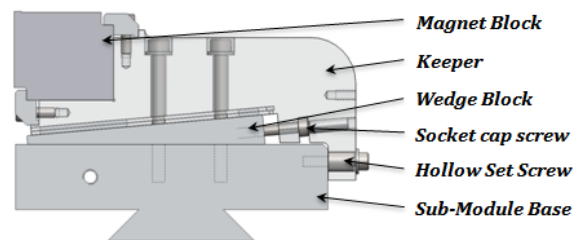

Figure 6: Mechanism of adjustment of the magnet position.

## IN-VACUUM UNDULATOR

In-vacuum undulators (IU) of three types are planned to be distributed over the storage ring as follows.

### 2-m IU22

Two sets of 2-m IU22 were designed (shown in Figure 7) and are being fabricated by Hitachi-Metal Company [6]. To increase the maximum magnetic field with a smaller gap, a hybrid magnetic structure is used. It is composed of vanadium steel and a NdFeB magnet (NMX-S38EH) of a sandwich type. As an application of future study, the undulators will be able to drive to the minimum gap, 3.5 mm. When the IU22 is operated at the minimum gap, a spring compensation system will settle between carriers to diminish the influence of the increased attractive force.

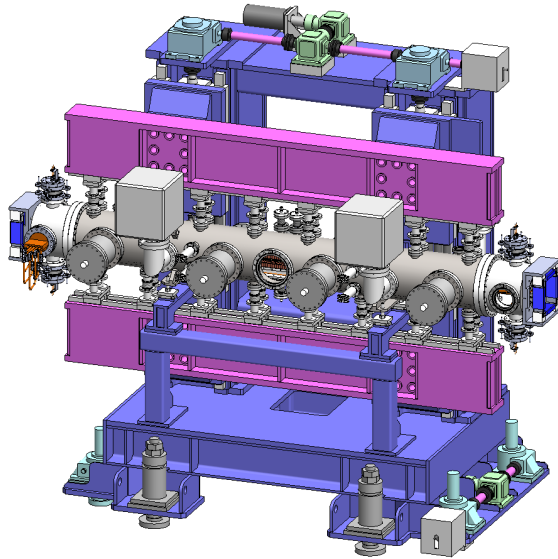

Figure 7: 2-m in-vacuum undulator with period length 22 mm.

### 3-m IU22

Four identical IU22 of length 3 m would be divided into two pairs, each of which is arranged in separate long straight sections. Figure 8 shows one pair as a sketch of two undulators distributed in one section.

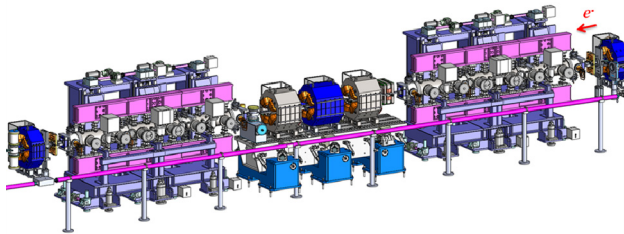

Figure 8: Two collinear IU22 with one phase shifter are planned in the long straight section.

### 3-m IU22T with Taper Function

The operational mechanism of this undulator is similar to the above 3-m IU22, except only that it has a taper movement added to the pair of magnet arrays. This function could provide a wider spectral bandwidth for sample scanning in a suitable photon spectrum. In this case, the machine must be able to incline 1 mm of height per overall length of the magnet array. To maintain the precision and accuracy of the equipment, junction areas between the carrier and the back beam will be capable of tolerating rotation and/or displacement. It is intended to purchase the 3-m IU22T with taper function is also open.

## CONCLUSION

The field correction of EPU46 is expected to be completed in 2012 and ready for installation in 2013. Engineering construction of EPU48 is planned to be finished in the third quarter of 2012; then field correction of the undulator will proceed after the EPU46 is completed. Two sets of 2-m IU22 will be delivered in mid 2012. Procurement of other in-vacuum undulators will begin from this year. To avoid interference conditions occurring in the installation, all undulators have been subjected to inspection with a 3D engineering drawing in a space interface with related components nearby.

There are three sets of Hall probe field measurement system in our laboratory for field mapping and quality verification purpose. Two systems are conventional granite bench with a carrier, one of them use pulley and roller as transmission system and total length is 4.5 m and the other 5 m long bench adopts linear motor and air bearing. An in-situ field measurement for an in-vacuum undulator without removing the vacuum chamber has been developing in house. Toward greater photon energy in the next step, a superconductive insertion device and a cryogenic permanent-magnet undulator are being considered for estimation and development.

## REFERENCES

- [1] <http://www.nsrcc.org.tw/english/tps.aspx>
- [2] D.J. Hwang, "Overview of TPS Beamlines", oral presentation material, May 2011.
- [3] <http://www.adc9001.com/NSRRC-Taiwan-EPU-4m>
- [4] C. Hs. Chang et al., "Construction and Performance of an Elliptically Polarized Undulator of Type Apple-II", ICMES 2009.
- [5] C. Hs. Chang et al., "Design and Development of an Elliptically Polarized Undulator of Length 3.5 m for TPS", IPAC10 2010.
- [6] <http://www.hitachi-metals.co.jp/e/eh2009/index.html>