

EXCITATION OF INTRA-BUNCH VERTICAL MOTION IN THE SPS - IMPLICATIONS FOR FEEDBACK CONTROL OF ELOUD AND TMCI INSTABILITIES*

J. M. Cesaratto[†], J. D. Fox, M. T. Pivi, C. H. Rivetta, O. Turgut,
S. Uemura, SLAC National Accelerator Laboratory, Menlo Park, CA 94025, USA
W. Hofle, U. Wehrle, CERN, Geneva, Switzerland

Abstract

Electron cloud (ecloud) and transverse mode coupled-bunch instabilities (TMCI) limit the bunch intensity in the CERN SPS. This paper presents experimental measurements in the SPS of single-bunch motion driven by a GHz bandwidth vertical excitation system [1]. The final goal is to quantify the change in internal bunch dynamics as instability thresholds are approached, and quantify the frequencies of internal modes as ecloud effects become significant. Initially, we have been able to drive the beam and view its motion. We show the excitation of barycentric, head-tail and higher vertical modes at different bunch intensities. The beam motion is analyzed in the time domain, via animated presentations of the sampled vertical signals, and in the frequency domain, via spectrograms showing the modal frequencies vs. time. The demonstration of the excitation of selected internal modes is a significant step in the development of the feedback control techniques.

MOTIVATION

For the LHC to operate at the full designed luminosity, the SPS must be able to provide beams with the appropriate intensity [2]. Intensity dependent effects like electron cloud (ecloud) and transverse mode coupling instabilities (TMCI) cause intra-bunch motion that can lead to emittance blowup and ultimately loss of beam in the SPS. As part of a feedback system, we have designed a high bandwidth excitation system to perturb the beam [1], then measure its motion. Measurements have focused on correctly timing the excitation system with the bunch, and exciting various bunch resonances to quantify the intra-bunch motion. We present initial results recorded at the SPS during November 2011 and April 2012.

INSTRUMENTATION AND SOFTWARE

The SPS RF frequency of 200 MHz corresponds to a 5 ns bucket size. Typical bunch lengths ($\sim 4\sigma$) are on the order of 2 – 3 ns at 26 GeV injection. The excitation system utilizes a 4.2 GS/s arbitrary waveform generator that (upon synchronization with the injection and revolution triggers) selects single or multiple bunches [1]. For each selected bunch and turn, a 32 (10 ns) or 16 (5 ns) sample excitation

signal is applied to the beam. A receiver hybrid provides the sum and difference signals from the pickup. The raw waveforms are digitized at 20 GS/s, and equalized offline in MATLAB using the inverse transfer function of the pickup and signal cables. The equalized sum and delta signals are further processed in MATLAB in both the time and frequency domains. Figure 1 is a schematic representation of the pickup and data processing to obtain the beam motion data.

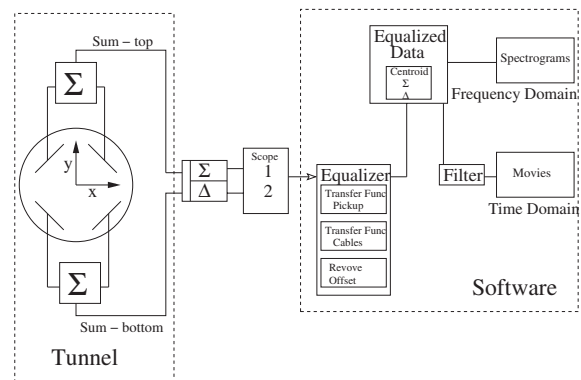

Figure 1: Schematic representation of the bunch signal processing from the pickup for beam excitation measurements in the SPS.

TIME AND FREQUENCY DOMAIN ANALYSIS METHODS

Our initial experiments centered on driving the beam through the amplifier array and verifying that the beam excitation amplitude was roughly consistent with the engineering level expectations for the applied kick and the beam configuration. In these initial studies a single bunch SPS beam, of intensity 1×10^{11} protons was studied at the beginning of the acceleration cycle at the injection energy of 26 GeV. We were able to easily excite modes 0 (barycentric) and 1 (head-tail) with a 200 MHz periodic sine wave signal modulated at the betatron frequency and first synchrotron sideband. The timing of the excitation system relative to the accelerating bunch was studied, and techniques were developed to sweep the excitation burst time overlap against the bunch. The measurements focused on precisely timing the kick with a single bunch and driving low-order mode bunch resonances.

The bunch motion in the equalized recorded data was

* Work supported by the U.S. Department of Energy under contract DE-AC02-76SF00515 and the US LHC Accelerator Research Program (LARP).

[†] cesaratto@stanford.edu

studied in the time domain, where a bandpass filter at the nominal betatron tune was applied to each beam “slice” along the axis of the recorded turns (effectively treating each of the “slices” as an independent signal). The resulting filtered data could then be rms averaged over the slices, resulting in a measure of the total “energy” or amplitude of beam motion independent of an excited mode. These measurements allowed us to study the amplitude of excited motion vs. excitation burst frequency and timing.

Figure 2 shows a snapshot of a time domain representation for the bunch rms motion with respect to turns. The system is excited by a swept 200 MHz sine burst which moved from a driving tune of 0.18 through 0.19, with the nominal betatron tune of 0.183. The top panel shows the rms of the vertical motion, which has a maximum at roughly turn 4600. The bottom panel shows the equalized delta signal for 25 turns around 4576, where in this case, the motion is barycentric. This method helps visualize the modal pattern excited in the vertical delta snapshot, while the time evolution of the rms amplitude reveals the coupling of the drive signal to the beam resonance, and also is a measure of the relative overlap of the kicker excitation and the beam. The timing of the excitation and bunch for this particular case can be compared to other bunch-kicker timings, and the signal can be adjusted to increase the head-tail motion. To ensure proper timing of the bunch with the signal, the inflection point of the 200 MHz sine wave excitation signal was varied with respect to the bunch centroid, and optimum timing was determined from the maximum rms value of (mode 1) head-tail motion.

Frequency domain analysis methods were also developed, which center on spectrogram methods to study the time evolution of the recorded equalized bunch signals after taking the FFT of each “slice” along the turn axis. This approach improves the signal/noise ratio through narrowband filtering. Figure 3 shows the frequency domain representation of the same transient of Figure 2, with a spectrogram study of power spectrum for slice 120 of the bunch (roughly 5.3 ns in Figure 2). The excitation signal (frequency chirp) can be seen sweeping through fractional tunes 0.18 – 0.19 over turns 1000 – 14000. At turns 4000 – 5000, strong mode 0 excitation is visible as the drive frequency overlaps with the resonance. As the excitation chirp continues and sweeps above the beam resonance, the beam continues to have excited motion with decreasing amplitude over about 8000 turns. Near turn 11000, the head-tail mode is weakly excited by the chirp as it passes through the first synchrotron sideband, and this head-tail motion is not clearly shown by simply looking only at the time domain representation. By looking at the data in both the time and frequency domains, we can more carefully find features that may not be visible in a single representation.

Modal Excitations and Random Excitations

Part of the motivation for this excitation system is to develop a diagnostic to study the evolution of the bunch tunes and modal patterns of motion. We were able to ex-

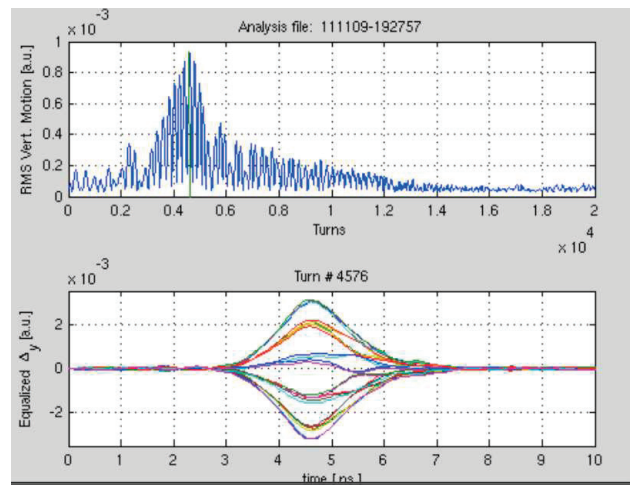

Figure 2: Top: RMS of the vertical motion weighted for all slices. Bottom: Equalized delta of the vertical motion showing strong barycentric motion for turns 4576 – 4601.

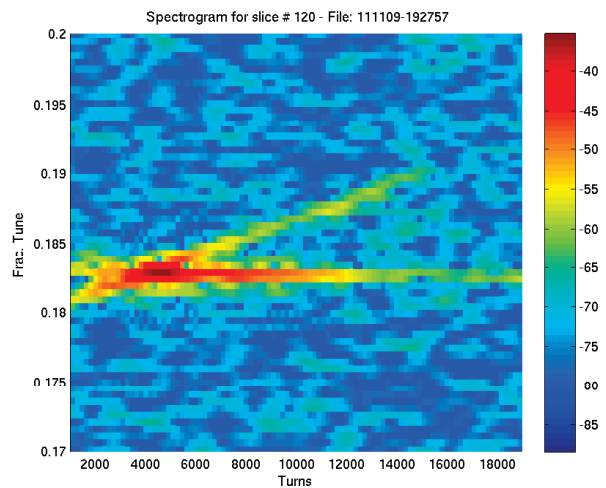

Figure 3: A spectrogram showing excitation of mode 0 at turn 4000 and weakly excitation of mode 1 at turn 11000 for a chirp from 0.180 - 0.190 in fractional tune. The betatron frequency is $f_{\beta} = 0.183$ and synchrotron frequency is $f_s \approx 0.005$.

cite multiple modes by driving a beam with low chromaticity. Figure 4 shows a power spectrum for an excitation that chirps through the modes 0, 1, 2, and 3. For these excitations, the betatron fractional tune was $f_{\beta} = 0.181$ and the synchrotron tune was $f_s \approx 0.004$. The excitation signal was applied from 2000 – 17000 turns and the excitation tune was swept from 0.175 – 0.188 as can be seen in the figure. As the chirp frequency overlaps the betatron tune and a synchrotron sideband, the vertical motion becomes strongly excited. Notice after the chirp passes through the mode 0 and mode 1 resonances that the motion is strong for those modes, i.e., the signal to noise ratio is roughly 35 – 40 dB. Although the chirp starts below one synchrotron

sideband less than the betatron fraction tune, no mode -1 is observed, which is not well understood. One potential explanation may be an asymmetric impedance providing damping for these negative modes. There also appears to be a correlation between even mode harmonics (and odd modes), e.g., when the chirp hits the mode 0 resonance at turn 9000, mode 2 is also visibly excited. Although weakly excited, mode 3 appears at turn 13000 when the chirp hits the mode 1 resonance. This too is not well-understood, but a possible explanation could be harmonic distortion in the power amplifiers. Testing of the amplifiers is ongoing.

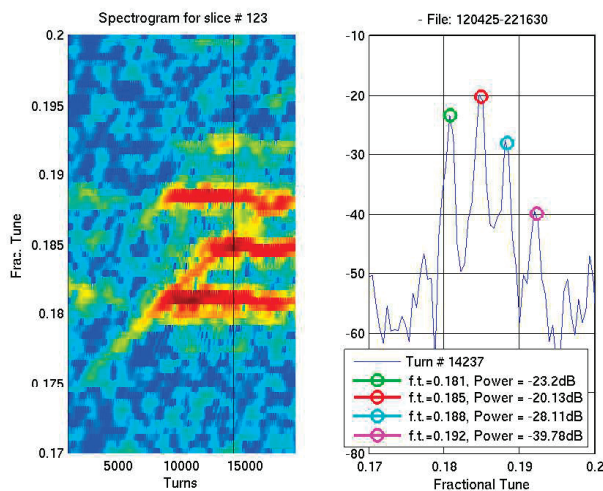

Figure 4: A spectrogram showing excitation of many intra-bunch modes for a frequency sweep from 0.175 – 0.188. The betatron frequency is $f_{\beta} = 0.181$ and $f_s \approx 0.004$. The signal to noise ratio for the measurement is >30 dB. The right panel of the figure is a power spectrum taken at near turn 15,000 showing the 4 excited modes.

Figure 5 shows the time domain representation of the same data as Figure 4. At turn 13401, the equalized delta signal of the vertical motion shows multiple modes, as can be seen when comparing with the spectrogram in Figure 4.

FUTURE PLANS

This project is still very much in its infancy with many smaller tasks and efforts ongoing to complete the feedback system. An analog equalizer is being developed for the pickup system so that corrections to the beam signal are made to account for signal distortion and attenuation by the pickup hardware and transmission cables in real time. A high bandwidth kicker system is currently being studied and a working group will provide CERN with a design report and suggested kicker(s) implementation [4]. Beam simulation efforts are ongoing with C-MAD, HeadTail, and WARP, with analysis tools being developed for both simulation and measured data, enabling direct comparison. All machine data taken to date has been with a single bunch, so we look forward to measurements exciting a particular bunch in a multi-bunch fill. In addition, future beam mea-

ISBN 978-3-95450-115-1

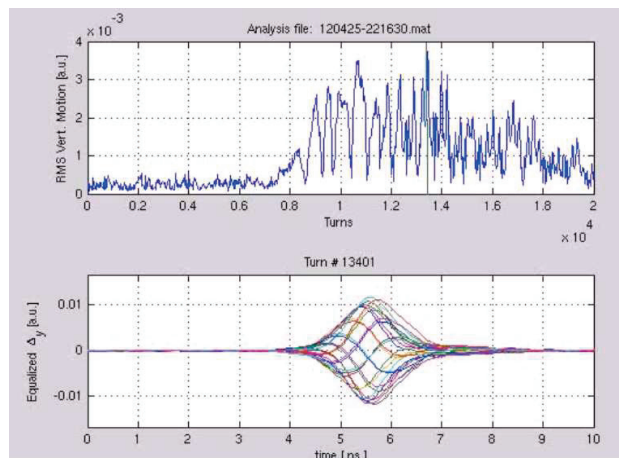

Figure 5: Top: RMS of the vertical motion. Bottom: Equalized delta signal showing multiple modes for turns 13401 – 13426.

surements will study intensity dependent effects to quantify tune shifts and dynamic effects from ecloud and TMCI.

CONCLUSIONS

Beam excitation and measurement in the SPS have been performed. Measurements of November 2011 and April 2012 show intra-bunch motion with multiple modes excited. We continue to develop new frequency domain analysis methods. Measurements will be ongoing throughout 2012 and we plan on beginning testing of a feedback channel prototype in late 2012.

ACKNOWLEDGMENT

The authors would like to thank Hannes Bartosik for his assistance providing beams at the SPS with various characteristics, the SLAC ARD, CERN AB RF departments, and the US LHC Accelerator Research Program (LARP) for their support. JMC would like to acknowledge the LARP Toohig Fellowship program.

REFERENCES

- [1] J. D. Fox et al., “A 4 GS/s Synchronized Vertical Excitation System for SPS Studies - Steps Toward Wideband Feedback,” WEPPR090, these proceedings.
- [2] E. Shaposhnikova et al., “Intensity Upgrade Plans for CERN-LHC Injectors”, 42nd ICFA Advanced Beam Dynamics Workshop, Nashville, TN, USA CERN-AD-2008-065 (2008).
- [3] R. de Maria, “Performance of Exponential Coupler in the SPS with LHC Type Beam for Transverse Broadband Instability Analysis,” DIPAC09, Basel, Switzerland, MOPD17, p. 83 (2009), <http://www.JACoW.org>
- [4] S. De Santis et al., “Study of a Wideband Feedback Kicker for the SPS,” WEPPP074, these proceedings.