

# THE UNDULATOR CONTROL SYSTEM FOR THE EUROPEAN XFEL

S. Karabekyan, A. Beckmann, J. Pflüger, European XFEL GmbH, Hamburg, Germany  
 N. Burandt, J. Kuhn, Beckhoff Automation GmbH, Verl, Germany  
 A. Schöps, DESY, Hamburg, Germany

## Abstract

The European XFEL project is a 4th generation light source. The first beam will be delivered in the beginning of 2015 and will produce spatially coherent  $\leq 80$ fs short photon pulses with a peak brilliance of  $10^{32}$ - $10^{34}$  photons/s/mm<sup>2</sup>/mrad<sup>2</sup>/0.1% BW in the energy range from 0.26 to 29.2 keV at electron beam energies of 10.5 GeV, 14 GeV, or 17.5 GeV [1, 2]. Three undulator systems are used to produce photon beams. Each undulator system consists of an array of undulator cells installed in a row along the electron beam. A single undulator cell itself consists of a planar undulator, a phase shifter, magnetic field correction coils and a quadrupole mover. This paper describes the design of the entire undulator control system including local and global control. It presents a concept of integration of the undulator control into the accelerator control system as well as into the experiment control.

## SYSTEM OVERVIEW

At the project start-up stage the three undulator systems SASE1, SASE2 and SASE3 will be used to produce photon beams (see Fig. 1). The electron bunch train is distributed into two branches by a flattop kicker magnet. These are the SASE1 and SASE2 beam lines, where hard X-ray beams are generated. After passing through SASE1 the electron bunches are used a second time by passing through the SASE3 undulator system to create an additional soft X-ray beam.

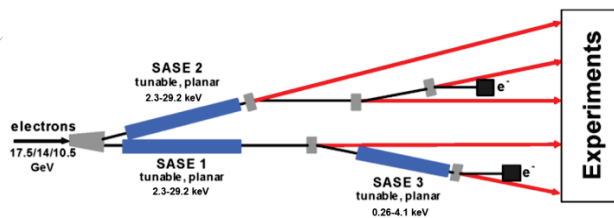

Figure 1: Schematic layout of the electron and photon beam distribution.

## Objectives

The undulator control system consists of global and local control systems. The objectives of the global control system are:

- Highly reliable control of the whole undulator systems.
- Integration of the undulator system control into the accelerator or experiment control.
- Synchronous movement of all undulator cells inside of one undulator system.
- Possibility of the movement-synchronization with external devices.

- Different operational modes with complex movement-schemes ( e.g. tapering of an undulator system, operation of a single or several undulator cells which could be necessary for diagnostic and maintenance).
- Flexibility for implementing additional controlled elements, e.g. a self-seeding mode.
- Handling of the slow control tasks (e.g. temperature monitoring, remote rebooting, handling the messages from firefighting system ...).
- Reliable error tracing and diagnostics.
- Simple and intuitive user interface.

The objectives of the local control system are:

- Gap control with low following error between master and slave axes ( $\leq \pm 10 \mu\text{m}$ ) in the full operational range (10mm $\div$ 220mm).
- Local temperature measurement and appropriate undulator gap correction.
- Undulator gap dependent air coil correction.
- Undulator gap dependent phase shifter control.
- Motion control for quadrupole movers.
- 3 way mixing valve control for the beam pipe temperature stability.
- Ambient magnetic field correction.
- Safe operation, damage prevention, proper and precise movement limitation, failure detection.

## Tolerance Requirements

The tolerance requirements for the undulator systems relevant to the control system are following [1-3]:

- Undulator gap control accuracy  $\pm 1 \mu\text{m}$ .
- Quadrupole mover positioning repeatability  $\pm 1 \mu\text{m}$ .
- Phase shifter gap control accuracy  $\pm 10 \mu\text{m}$ .
- Maximal steering power for air coil correctors  $\pm 0.6 \text{ Tmm}$ .
- Compensation of an ambient magnetic field of up to  $150 \mu\text{T}$ .
- Accuracy of the temperature measurement of magnet structures  $\pm 0.03 \text{ K}$ .

## LOCAL CONTROL OF UNDULATOR CELL

An undulator cell consists of a 5m long undulator segment and a 1.1m long intersection (see Fig. 2). Four servo motors are used on each undulator to control the gap between girders with micrometer accuracy. One stepper motor is used for phase shifter control, and two other stepper motors control the position of the quadrupole magnet. The current of magnetic field correction coils as well as the gap of the phase shifter are adjustable as a function of the undulator gap. The control of the vacuum chamber temperature as well as correction

of the ambient magnetic field is also in the scope of the local control system.

The local control system is based on industrial components produced by Beckhoff Automation GmbH and a Programmable Logic Controller (PLC) implemented in the TwinCAT system [3].

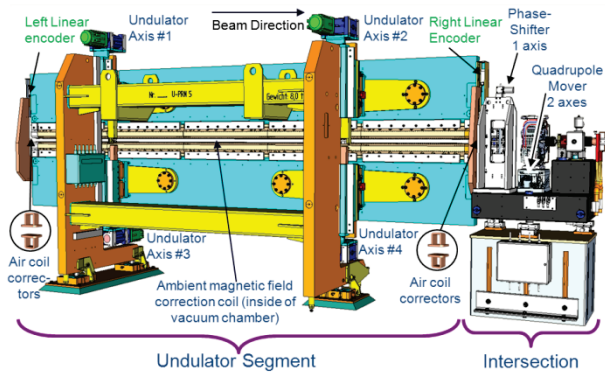

Figure 2: Undulator cell. Undulator segment and intersection in array.

### GLOBAL CONTROL OF UNDULATOR SYSTEMS

The motion control of an undulator system consists of the following main components:

- **Central Control Node (CCN):** is the middle layer of the undulator control system. This node on one hand controls the entire undulator system, and on the other hand provides the interface to control the undulator system from external clients.
- **EtherCAT fieldbus system:** is used for the local control of the components and for communication between CCN and LDMC
- **Local Device and Motion Control (LDMC):** is a PLC which runs on industrial PC and controls all front-end devices that belong to one undulator cell.
- **Motors:** four servomotors for an undulator, one stepper motor for a phase shifter and two stepper motors for quadrupole mover
- **Beam trajectory correctors:** by means of air coil correctors
- **3-way valve controller:** is used for thermo-stabilization of the vacuum chamber
- **Feedback System:** based on absolute linear encoders, absolute multi-turn rotary encoders, LVDT position sensors, and a temperature measurement system.

#### Control System Layout

The local control of each undulator cell can be designed in the way that only one virtual axis represents the undulator for the global control. Inside of the local control system all axes and parameters depending on the magnetic field strength i.e. on the undulator gap, are coupled to this one virtual axis (see Fig. 3.). The implementation of this scheme will allow for synchronising the movements of all undulator cells inside

of one undulator system. The starting time for the movements of the individual undulator cells could be precisely synchronized ( $\ll 1\mu s$ ) by implementation of the EtherCAT fieldbus system in the local control as well as between the LDMC and CCN.

Four undulator axes, one phase shifter axis and four air coil correctors are the components which can be controlled locally and coupled to the virtual axis. Nevertheless the LDMC also contains components like a quadrupole mover, an ambient magnetic field correction coil or 3-way valve which are not directly depending from the undulator gap. So these components are not coupled to the virtual axis.

The Central Control Node is a separated Windows PC which is connected to each LDMC over the EtherCAT network. The global control program is also implemented in a Beckhoff PLC and TwinCAT System Manager. The PLC program running on this computer has two main tasks. The first task is to control all undulator cells which belong to one undulator system. The second task is to provide the interface to the accelerator or experiment control. This interface can be used for instance by a DOOCS (Distributed Object Oriented Control System) server or any other server that has access to the undulator control system. It will ensure communication between the global control PLC and the remote control clients.

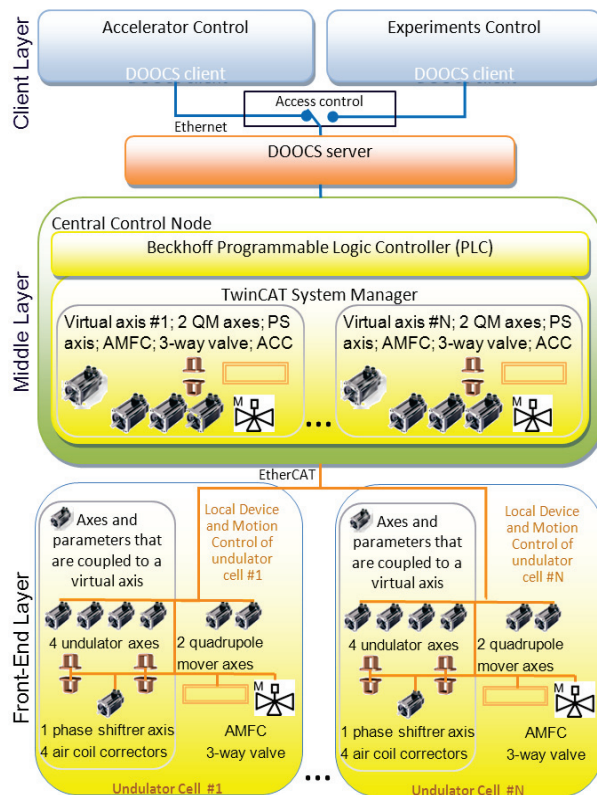

Figure 3: Schematic overview of the undulator control system.

The global control PLC is designed to allow for synchronized motion using concept of virtual axes. In

addition it permits access to all other components of the system as required.

The advantages of the multi-PLC system layout will be used for managing slow control tasks, like temperature monitoring in the racks, remote restarting of undulator PCs by means of a neighbouring PC, or handling the messages from the fire-fighting system.

*Network Topology*

The CCN will be installed in the balcony computer service rooms, which are located above the tunnels entry in the XHEXP1 experimental building. One CCN will serve one undulator system. The CCN connects to its undulator system through the nearest tunnel by means of optical fibres. The undulator cells are daisy-chained by copper cable.

For the undulator system a “Redundant Ring Topology” will be used, which allows to build a ring topology that

can tolerate a single point failure. Each SASE string will have two redundant rings; Ethernet and EtherCAT.

The EtherCAT network is used for real-time device and motion control, while the Ethernet is used for monitoring and remote access to the individual undulator PCs.

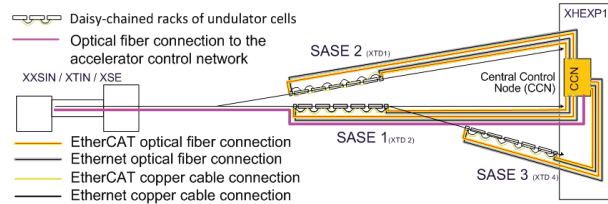

Figure 4: Layout of the network topology.

The CCN will also have a dedicated optical fiber connection to the accelerator control system, which will be located in the injector building. The layout of one undulator control system is shown in Fig. 5.

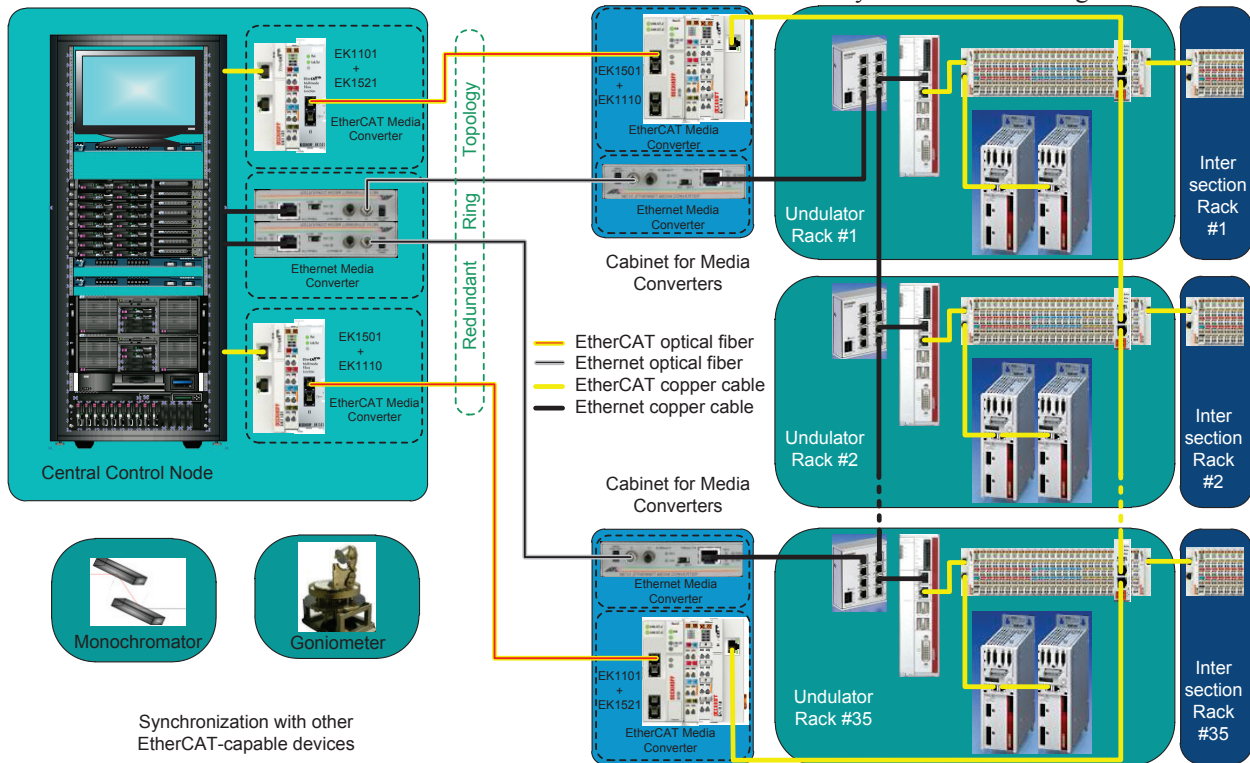

Figure 5: Layout of one undulator control system.

*Control Parameters for Undulator System*

It is foreseen that user experiments will have selected control over the following parameters of the undulator system:

- Photon beam energy (system gap).
- Gap taper (to optimize photon beam intensity).
- Synchronization with external devices.

In contrast the accelerator control will have full access over the all undulator system parameters.

**REFERENCES**

- [1] M. Altarelli et al., Eds., “The European X-ray Free-Electron Laser: Technical Design Report,” DESY 2006-097, July 2007.
- [2] Th. Tschentscher, “Layout of the X-Ray Systems at the European XFEL,” Technical Report, April 2011, TR-2011-001, doi:10.3204/XFEL.EU/TR-2011-001.
- [3] S. Karabekyan, R. Pannier, J. Pflüger, N. Burandt, J. Kuhn, A. Schöps, “The Local Control System of an Undulator Cell for the European XFEL,” ICALEPCS2011, Grenoble, October 2011, MOPMU012, p. 450 (2011).

Copyright © 2012 by IEEE – cc Creative Commons Attribution 3.0 (CC BY 3.0) — cc Creative Commons Attribution 3.0 (CC BY 3.0)