

ILC CONVENTIONAL FACILITY IN ASIAN SITES

Atsushi Enomoto and M. Miyahara, KEK, Tsukuba, Japan

Abstract

The international linear collider (ILC) is on a stage of preparing technical design report (TDR). Through value engineering to reduce civil construction costs, the tunnel configuration was changed from double-tunnel scheme to single. The double-tunnel scheme accommodates superconducting accelerator modules and their power supplies independently. This is a very natural scheme for setting an accelerator and its power supply nearby and for preventing radiation damage of the power supply. However, the single-tunnel scheme was proposed to reduce cost, and to avoid such radiation problem three kinds of high-level RF (HLRF) systems are proposed. We report the comparison of ILC main linac costs and construction schedules between eight cases for combinations of different tunnel excavation methods and HLRF systems; then, we report the potential facility design for the Asian sites.

INTRODUCTION

The ILC will be an electron-positron beam collider composed of seven individual systems: an electron (e-) and a positron (e+) source, damping rings (DRs), ring-to-main-linac (RTML) for beam transport, the main linacs (MLs), beam delivery system (BDS), and detector hall (DH). The DRs, RTML, MLs, and BDS will be installed

in each e- and e+ accelerator sides. The total length of the accelerator will be approximately 30 km and will be operating at a centre-of-mass collision energy of 500 GeV. The e- source, the e+ source, DRs, BDS, and DH will be located at the central region of the ILC.

SITE LAYOUT

The Asian region civil design has the following site-specific features since it is to be constructed on hard bedrock of deep underground at one of the Japanese mountainous site candidates:

- The ML tunnel meets the requirement for distributed klystron system (DKS).
- Instead of TBM (tunnel boring machine), NATM (New Austrian Tunneling Method) is employed.
- The underground structures are divided into seven areas along ILC with a maximum span of +2.5 km.
- Instead of vertical shafts, access tunnels (ATs) with a slope are used to access the underground halls (AHs).
- Some surface facilities are moved into underground.

The Asian site overall site layout is shown in Fig. 1. The ML consists of 285 (e-) and 282 (e+) RF units. For DKS, the ML cryomodule configuration is based on the 9-module string as shown in Fig. 2.

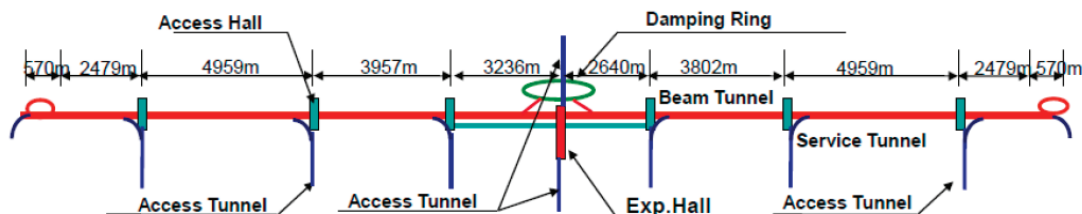

Figure 1: Overall site layout in the Asian site.

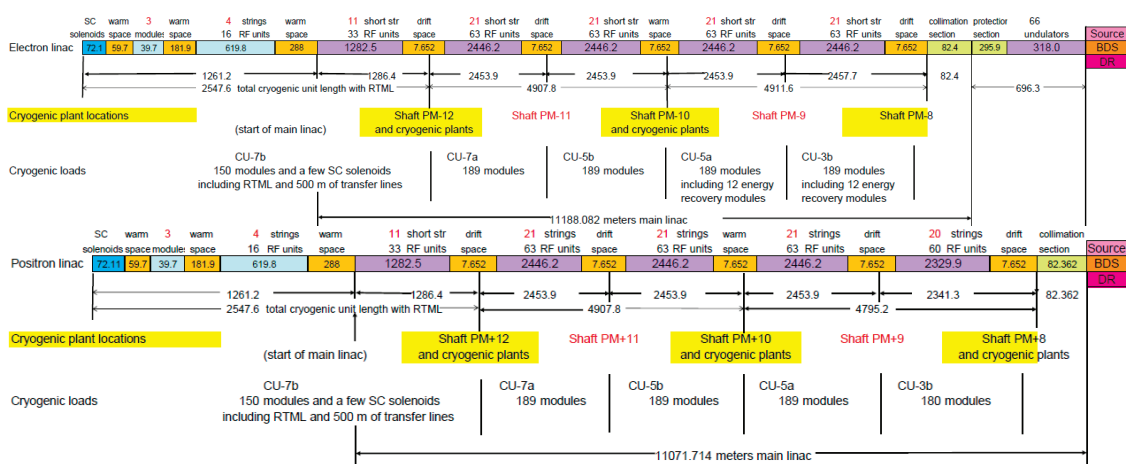

Figure 2: Cryogenic system configuration and cryogenic plant location in the Asian site.

Copyright © 2012 by IEEE - cc Creative Commons Attribution 3.0 (CC BY 3.0) — cc Creative Commons Attribution 3.0 (CC BY 3.0)

CIVIL DESIGN

Main Linac Tunnel

To investigate the tunnel construction cost and schedule, the following eight cases (Fig. 3) are studied regarding tunnel excavation methods (TBM or NATM) and single tunnel configurations.

- Cases 1 to 5 use TBM and cases 6 to 8 use NATM.
- Cases 1 to 5 compare facilities with different HLRF systems (RDR, XFEL, KCS, and DRFS).
- Cases 6 and 8 compare single tunnel with auxiliary small tunnel and with centre walls.

By this study it was seen that a single tunnel excavated by NATM is most cost effective in Asian site. Although we have further advantages such as flexible excavation of tunnel section and less construction risk, an obvious disadvantage is the slower excavation speed (~100 m/month) of NATM. However, this disadvantage could be mitigated in the following way. NATM does not need such preparation time as required in TBM commissioning. A short-distance excavation is not cost-effective in TBM but not the case in NATM. Thus parallel work can be conducted in shorter construction zone and the NATM is not necessarily slower than TBM in the Asian site.

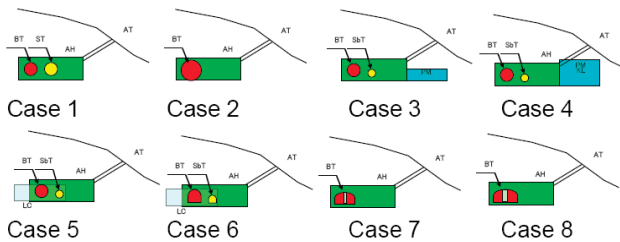

Figure 3: Tunnel configuration variance for case study.

The ML tunnel section is divided by a centre wall into beam and service tunnel as shown in Fig. 4. Each tunnel section has functional zones for the equipment installation, survey, conveyance, and human egress. In each tunnel, the right side of accelerator equipment (cryomodule and modulator) is equipment-conveyance and human-egress zone. The left-side of the equipment is working space but used as a detour even if the egress zone is occupied by equipment. The water pipes are installed basically in lower part. The electric power lines are installed in (shielded) cable racks hanging at the ceiling. Taking a consideration of these configurations, a necessary tunnel width is 7.5 m at minimum except the centre shield wall.

The centre wall is necessary for the radiation shield to protect human in the service tunnel. The foot thickness of the wall is 3.5 m and the upper side thickness is 2 m. In every 3-4 rf units at the empty area of modulators, a connection passage between the beam and service tunnels is constructed (Fig. 5). This is used for evacuation of human from accident to opposite side. For the passage way, the centre wall thickness can be increased by a

maximum of 2 m forward the service tunnel direction up to the front end of the modulator rack. The shield effect of the wall and passage way was simulated assuming a beam loss and referring to a radiation safety regulation.

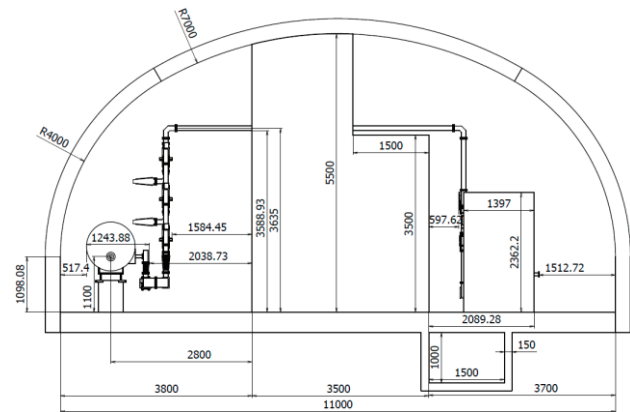

Figure 4: "Kamaboko"-shape section of ML tunnel.

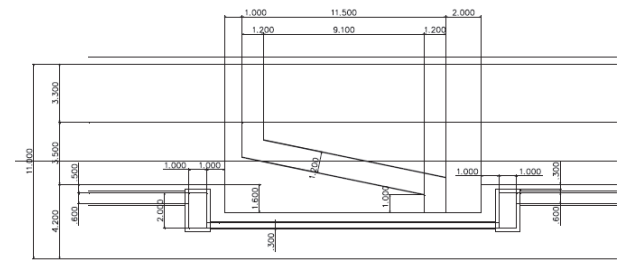

Figure 5: Passage way between beam and service tunnels.

Big size caverns

The AH and DH sizes are similar to those of underground hydroelectric power plants in Japan. Since the detector hall access is not by vertical shaft used at LHC but by a sloped tunnel, the design is underway taking account of assembly, operation, and maintenance process for two push-pull detectors (Fig. 6).

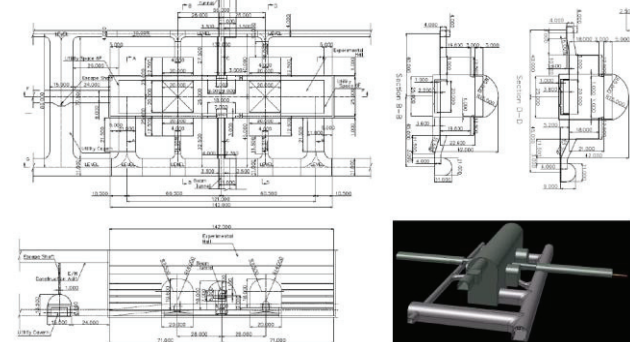

Figure 6: Detector hall designs.

ELECTRICAL DESIGN

The power (216 MW) is distributed in three stages:

- The site electric power is stepped down from high-voltages (150-500 kV) to 66 kV in the main substation and distributed to seven underground halls (6 AHs, 1 DH).
- The 66-kV electricity is further stepped down to 6.6 kV at each AH/DH substations and distributed local areas within +2.5 km.
- RF modulators and cryogenic warm compressors are powered directly at 6.6 kV and low voltages are stepped down from 6.6 kV in local substations.

The main substation diagram is given in Fig. 7: Four 100-MW transformers (including one back-up) are installed with spaces for the two for future 1 TeV upgrade. The capacity of the access hall 66/6.6-kV transformers is equalized to be two 30-MW by reasons of maintenance.

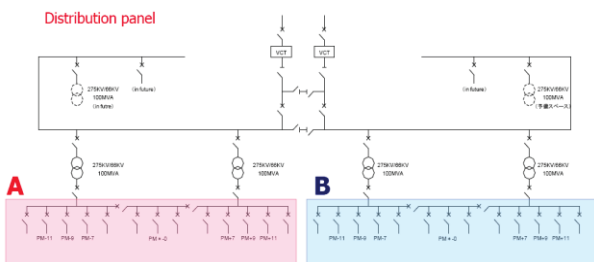

Figure 7: Main substation single-line diagram.

MECHANICAL DESIGN

The mechanical design is based on the heat-load criteria collected from the technical group as shown in Fig. 8. The criteria are integrated in each seven underground area. Figures 9 and 10 are the typical mechanical designs for the cooling-water system and piped utilities at an AH.

Components	Quantity Per m	Location	Average		Heat Load to		Max Allowable		Supply		Delta		Water		Maximum		Typical		Acceptable		Racks		Power to	Max		
			Head Load (KW)	Temp (C)	Temp (C)	Temp (C)	Temp (C)	Temp (C)	Temp (C)	Temp (C)	Temp (C)	Temp (C)	Temp (C)	Temp (C)	Temp (C)	Temp (C)	Temp (C)	Temp (C)	Temp (C)	Temp (C)	Temp (C)	Temp (C)			Temp (C)	Temp (C)
RF-related Technical Components only																										
RF Charging Supply	1154 m	Klystron Center	4.0	2.8			40	40	1.27	18	5	10	0	3.3											Bg F (m)	
Switching power supply	1154 m	Klystron Center	7.5	4.5			35	35	0.50	7.5	33	5	10	0	3.0											
Modulator	1154 m	Klystron Center	7.8	4.5			35	35	1.21	20	30	5	n/a	0	3.0											
Electron Socket Tank / Gun	1154 m	Klystron Center	1.0	0.8	50	35	1.35	30	35	3	n/a	0	0.2													
Klystron - Focusing Coil (Solenoid)	1154 m	Klystron Center	4.0	5.5	80	55	0	10	15	1	n/a	0	0.4													
Klystron Collector	1154 m	Klystron Center			47.3	45.8	87	37	18	37	55	0.3	n/a	0	3.4											
Klystron Body & Windows	1154 m	Klystron Center	4.3	4.0	25.10	20.0	6	10	15	4.5	+1.5 C	0														
Relay Racks (Instrument Racks)	1154 m	Klystron Center	10.0	0	N/A	N/A	N/A	N/A	N/A	N/A	N/A	None	11.5	-1.5												
Attenuators	3054 m	Cryomodule Center	0	0	N/A	N/A	N/A	N/A	N/A	N/A	N/A	None	0.0													
Waveguide (in Cryomodule Corridor)	1-1504 m	Klystron Center	0	0																						
Waveguide (in penetration)	1-1504 m	Cryomodule Center	0.675																							
Waveguide (in Cryomodule Corridor)	1-1504 m	Cryomodule Center	0.0																							
Circulators With loads (isolator)	3054 m	Cryomodule Center	2.49				35	0.45	per load																	
Loads	3054 m	Cryomodule Center	30.05				35	0.47	per load																	
SUBTOTAL			101				Total RF heat loss (less racks)=		116.1																	

Figure 8: An example of heat load table (ML).

The cooling-water system is based on 3-loop system and the third-loop temperature cooling equipment is 34C in supply and 45C in return. Chilled water (7C supply and 18C return) is used to cool instrument racks and the air of

service tunnel. The system is the same as in Fig. 9 except using refrigerator. Tunnel inflow water is utilized for the makeup water for cooling towers as shown in Fig. 10.

Fresh ambient air cooled/dehumidified in summer and heated in winter, kept 29C and 35%, is supplied to the underground by large-bore ducts through access tunnels. The air blows in the tunnel without ducts at a flow rate of ~0.5 m/s, see Fig. 11.

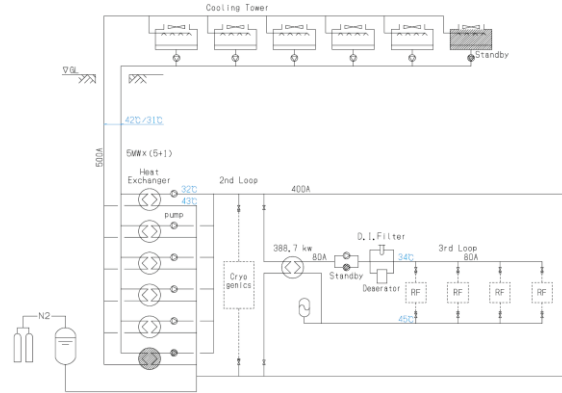

Figure 9: Cooling-water system.

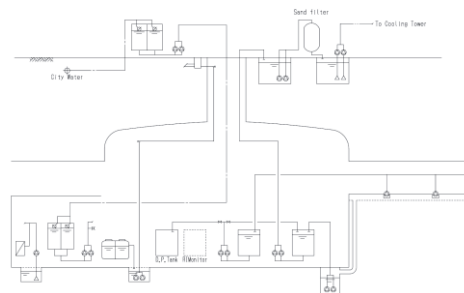

Figure 10: Piped utilities.

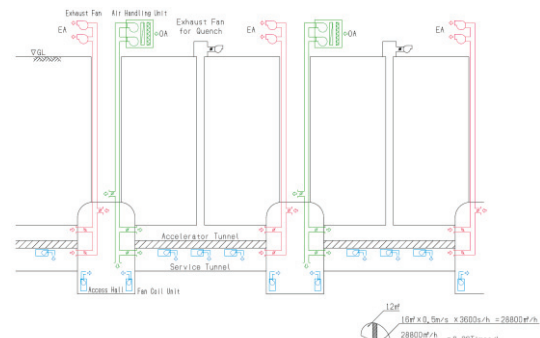

Figure 11: Air ventilation system.

REFERENCES

[1] A. Enomoto et al., "The Asian regional proposal for a single-tunnel configuration for the conventional facility", Linac2010, Tsukuba, Japan, July 2004, MPO028, p.115.

Copyright © 2012 by IEEE - cc Creative Commons Attribution 3.0 (CC BY 3.0) — cc Creative Commons Attribution 3.0 (CC BY 3.0)