

## DESIGN OF A SPOKE CAVITY FOR RIKEN RI-BEAM FACTORY \*

L. Lu, N. Sakamoto, K. Suda, K. Yamada, O. Kamigaito,  
RIKEN Nishina Center for Accelerator-Based Science,  
RIKEN, 2-1, Hirosawa, Wako, Saitama 351-0198, Japan

### Abstract

A spoke type cavity, which would be used as a rebuncher for uranium beams, has been studying [1]. The aim is a 4-gap cavity designed for 219 MHz resonance frequency. This resonator will be operated at a velocity of  $\beta = 0.303$ . The estimated peak voltage is rather high as 3 mega-voltages (MV).

In the frame, this research has been initiated for future upgrade scheme of our heavy ion acceleration facility. The cavity should be designed, built and tested within next few years. And the cavity is also aimed as a prototype for the fabrication process development.

The initial cavity designs and the simulated results by used the Microwave Studio code (MWS) will be reported in this paper.

accelerate very heavy ions such as uranium up to very high energy. As shown in Fig. 1, there are two charge-stripping (ST) sections in the mode of uranium beam acceleration. One is located after RRC ( $\beta = 0.16$ ), and the other is after fRC ( $\beta = 0.303$ ). These Stripping sections cause increases in the phase width of the beam in the subsequent cyclotrons. The purpose of our researcher is aiming to use this new tri-spoke cavity as a rebuncher to focus the beam in longitudinal. The tri-spoke cavity would be placed between fRC and IRC.

Although a higher frequency helps to reduce the cavity length, the beam phase at the cavity becomes too large to be well bunched. The rf frequency of the tri-spoke cavity was chosen to be 219 MHz, which is the 12<sup>th</sup> harmonic of the fundamental frequency of 18.25 MHz, as shown in Fig. 1. This frequency gives the cell length of  $\beta\lambda/2 = 207$  mm at  $\beta = 0.303$ . This resonator is proposed to operate at 4.2K. The total voltage required for the cavity is estimated to be 3 MV at this frequency.

The MWS is used to design the cavity design and calculate the cavity electromagnetic simulation. The soft ANSYS is used to calculate the mechanical calculation of cavity.

### INTRODUCTION

At the RIKEN RI-beam factory (RIBF) [2], the accelerator chain, which consists of a new linac named RILAC2 with a powerful superconducting ECR ion source [3] and four booster cyclotrons (RRC: K = 540 MeV, fRC: K = 570 MeV, IRC: K = 980 MeV, and SRC: K = 2600 MeV), as shown in Fig. 1 [4, 5], could

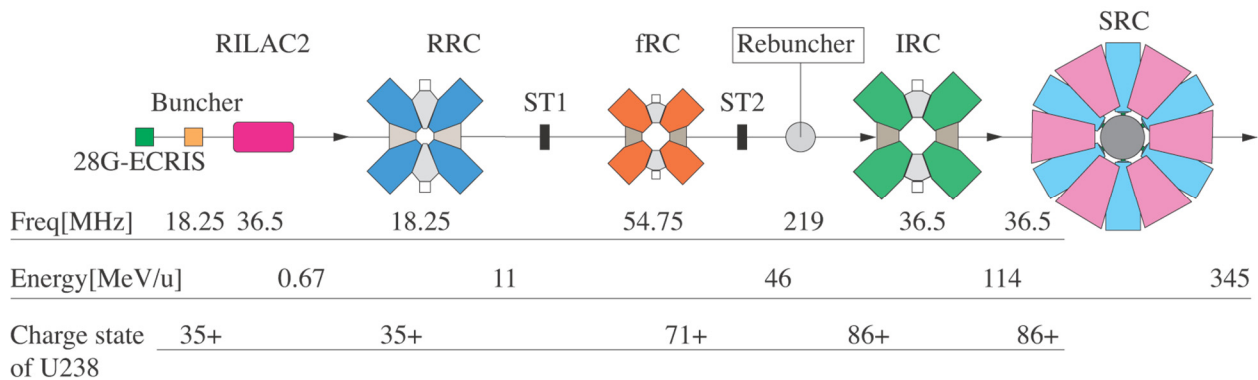

Figure 1: Accelerator chain of RIKEN RIBF for <sup>238</sup>U ions.

### DESIGNS

#### Parameters

The spoke structure is popularly used in the medium  $\beta$  region because the ratio of  $E_{pk} / E_{acc}$  is low. However, one disadvantage is that the axial E field in the end gaps of the spoke structure is always lower than that in other gaps in normal spoke cavity design. In our research, a design of a flat axial E field distribution was gained by slid the positions of 1<sup>st</sup> and 3<sup>rd</sup> stem to the end walls. Additionally,

making cavity rf design, fabrication technology and structural parameters had to be taken into account. The whole our rf design has been adopted two main goals – the simplest technology of cavity manufacture and to thee prime goal of the project to achieve the best possible structural parameters.

The geometry and parameters of the initial cavity are shown in Fig. 2 and list in Table 1. This designed structure shown in Fig. 2 could gain a flat axial E field by rearranging the first and third stems. The simulated axis field distribution showed in Fig. 3. The separation of the resonated modes of this structure is also easy [1].

\*luliang@riken.jp

\*Work supported by Foreign Postdoctoral Researcher Program

The stem structure was also tried to design as simplest as possible, which could be fabricated from a thin Nb sheet by using press method and electron beam welding method. The position of coupler was designed at the center of cavity, vertical direction of 2<sup>nd</sup> stem. The vacuum port could be installed on the other side. This symmetry looks attractive because of the symmetry of its position. The magnetic field in this region equals zero. And two maintenance ports for cavity cleaning were designed in the side wall because the magnetic field is not concentrated there.

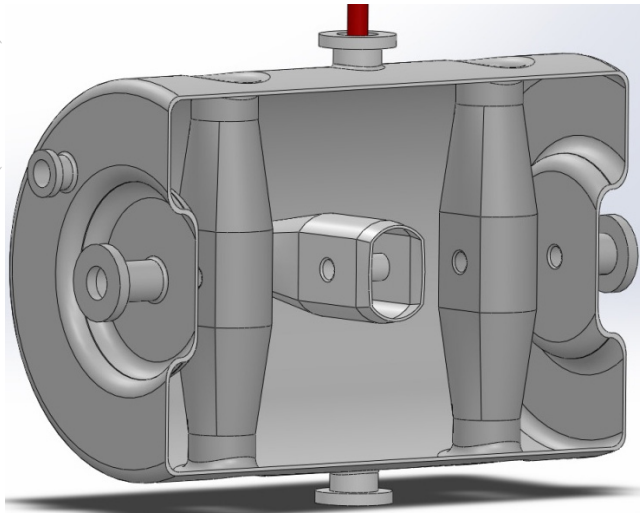

Figure 2: 3D view of tri-spoke cavity with coupler and vacuum port.

Table 1: Summarized Advantages of Each Structure

Parameter	Nominal Value
Frequency	219 MHz
$\beta = v/c$	0.303
Internal Length	828.8 mm
Cavity Internal Diameter	290 mm
Beam Bore Diameter	15 mm
Shifts of 1 <sup>st</sup> & 3 <sup>rd</sup> stems	34 mm
R/Q	241.21 $\Omega$
$E_{pk}/E_{acc}$	2.75
$H_{pk}/E_{acc}$	58.21 Oe/MV/m
G	81.17 $\Omega$
$R_{res}$ @ 4.2K (assumed)	25 n $\Omega$
Q @ 4.2K	3.25E+09 $\Omega$
Dissipated power @ 4.2K	0.42 W
Tuning sensitivity	265.25 kHz/mm

The cavity tuning method was adopted end-wall tuners. Tuning effects of the cavity frequency and the axis E field

are shown in Fig. 4. Shown in Fig. 4, both the changes of the frequency and the axis E field ( $E_{gap1} / E_{gap2} = E_{gap4} / E_{gap3}$ ) show a linear decreasing change and a linear increasing change, respectively.

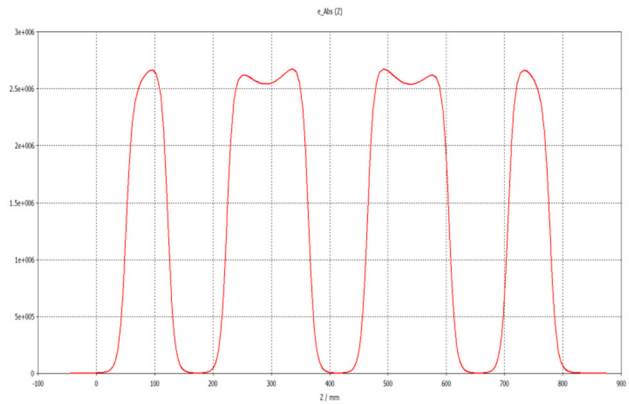

Figure 3: One of simulated results of the axis E field distribution of cavity.

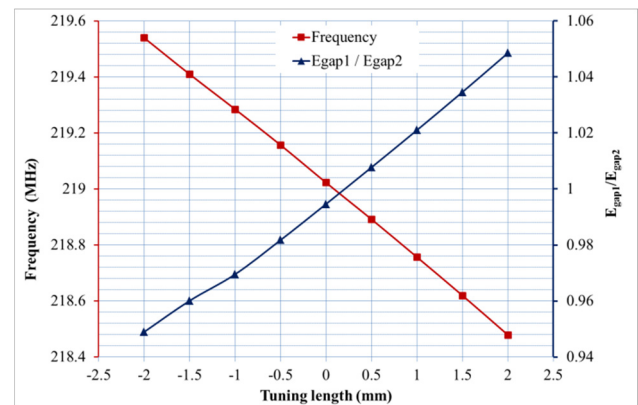

Figure 4: The tuning results of the resonator frequency change and the axis E field change.

### Mechanical Calculation

The Niobium walls are supposed to be formed of 5 mm thick Nb sheets. The total pressure acting on the surface of the cavity is supposed to be 0.121325 MPa. The simulated results shown in Fig. 5 showed that the maximum deformation was about 0.79 mm appeared in end wall. It is clear to see that the position of the maximum deformation is the electrode edges of the end-wall. And the deformation of the whole cylinder was very small. According to these simulations, the pre-designed radial ribs located in end wall were removed.

Another model, which installed the simulated deformation results shown in Fig. 5, was used to confirm the changes of the resonator frequency and the cavity E field distribution. The simulated results pointed that both the changes of frequency and E field distribution was small, and both the changes was under the control of the wall tuning.

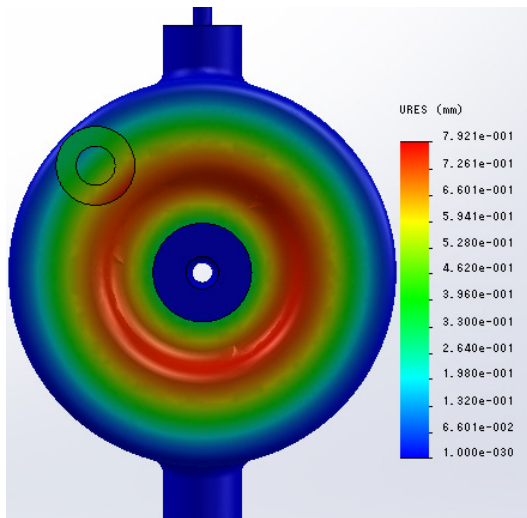

Figure 5: 3D view of tri-spoke cavity with coupler and vacuum port.

*Fabrication Model*

The fabrication of parts of the designed tri-spoke will be prepared to use press method to shape the feature from Nb sheets. And each pressed parts will be welded by using electron beam welding method. For training skilful technician and practicing the welding technic, a full scale copper cavity model, which is assembled by three divided module parts of the designed cavity shown in the left part of the Fig. 6, will be built using the same fabrication

technology that is supposed for Nb cavity manufacture. The image of the assembled fabrication model, which is designed to be assembled by two end-walls and one triparted cavity, is shown in the right part of the Fig. 5. All the molds for fabrication model can also be used in the fabrication of Nb cavity that can make the fabrication of the Nb cavity cost down. Based on simulations, the maximum displacement is 0.79mm for copper and 0.82mm for Nb.

This fabrication model will be also used to check, firstly, the errors of the mechanical dynamic analysis mentioned above; secondly, the wall tuning effects and the flatness of the cavity axis E field distribution; and thirdly the tolerable accuracy in the mechanical construction.

*Next Steps*

There are three major works to be concerned in the future steps. One is about post processing, one is about the design of the power coupler, and the last is about the designs of the helium vessel and vacuum vessel. About post processing of the cavity such as surface polishing, cleaning and baking, we had begun to study the basis and prepare the equipment for initial research. Power coupler will be designed as a coaxial structure with inner and outer conductors, and also should contain two insulating windows: one warm and one cold, which enable the whole coupler to be divided into warm and cold sections. The design of the helium vessel and the vacuum vessel will be concerned after finishing the measurements of the fabrication model.

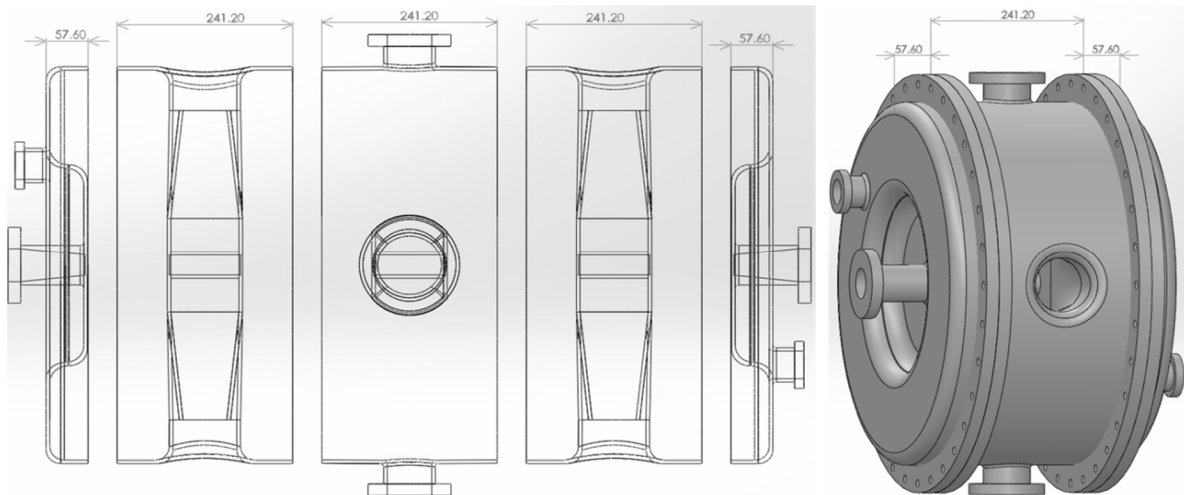

Figure 6: Images of the wall flanges and the triparted cavity from original design, and the fabrication model.

**ACKNOWLEDGMENT**

We would like to thank Dr. Tsuyoshi Tajima, Dr. Evgeny Zaplatin and Dr. P. Ostroumov for giving us many advices on material, designs and fabrication.

**REFERENCES**

[1] L. Lu et al., Proceedings of SRF2011, Chicago, USA, MOPO028, (2011).

[2] Y. Yano, Nucl. Instr. and Meth. B 261 (2007) 1009.  
 [3] Y. Higurashi et al., Proceedings of IPAC10, Kyoto, Japan, THPEC060, (2010).  
 [4] K. Yamada et al., Proceedings of IPAC10, Kyoto, Japan, MOPD046, (2010).  
 [5] K. Suda et al., Proceedings of IPAC10, Kyoto, Japan, THPEA023, (2010).  
 [6] H. Podlech, U. Ratzinger et al., Phys. Rev. ST Accel. Beams 10 (2007) 080101.