

THE MAIN STOCHASTIC COOLING SYSTEM OF THE HESR

R. Stassen, R. Greven, R. Maier, G. Schug, H. Stockhorst, Forschungszentrum Jülich, Germany

Abstract

The main stochastic cooling system of the High-Energy Storage Ring HESR (1.5-15 GeV/c) for antiprotons at the FAIR complex (Facility for Antiprotons and Ion Research) in Darmstadt (GSI) will work in the frequency range of 2-4 GHz. The design work on the pickups and the kickers is now finished, and the production of the first cooling tank has been started. The layout of the whole system will be presented taking into account new additional requirements concerning the accumulation and the cooling of heavy ions. All beam-coupling structures are nearly identical and contain several ring-slot blocks. These blocks consist of eight wall-current monitors coupled out by eight electrodes each. Most of the signal combining and splitting take place within the vacuum envelope to reduce the number of vacuum RF feed throughs. The long-distance transmission of the signals and the filters containing long signal delays work with near infrared optical elements.

Stochastic cooling system, Pickup

The main stochastic cooling system of the HESR operates in a frequency range of 2-4 GHz. The beam coupling structure is based on slot-ring couplers [1] surrounding the whole beam thus covering the total image current. In a small test-tank these structures were successfully operated in the synchrotron COSY [2] as pickup only and in a small version of 16 rings, as pickup and kicker in the Nuclotron in Dubna. This small cooling system acts as test-bench for the NICA project [3].

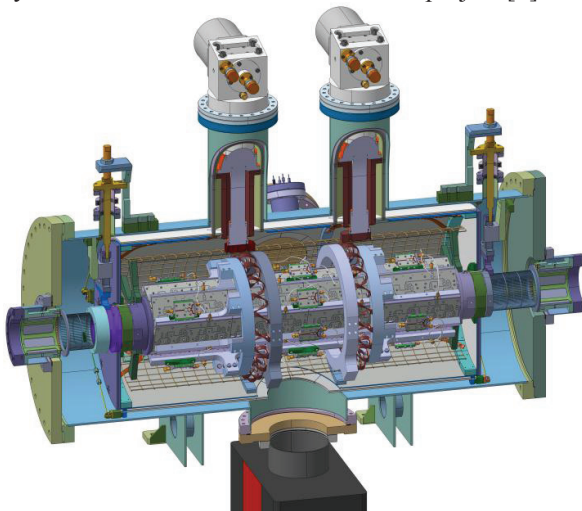

Figure 1: Completed design of pickup tanks.

These structures have the great advantage that they can be simultaneously used in all three cooling planes (horizontal, vertical and longitudinal). Another advantage in the case of the HESR is the fact that no movable part in

the vacuum is needed to obtain a good signal to noise ratio.

The demands on the performance of the stochastic cooling system changed several times during the design phase. The accumulation of pbars in the HESR due to the postponed RESR can be done only by increasing the available RF-power for the longitudinal cooling [4, 5] (see kicker section). Besides the main 2-4 GHz system, a second 4-6 GHz system is needed to fulfil the requirements in the high-resolution mode. This second system will be used for additional longitudinal cooling only and will have a similar design, but is still in the prototype phase.

Figure 1 shows the drawing of the completed pickup tank design including optimized cryo pump connections and ferrite dampers, which were successful tested at the Nuclotron in Dubna. Two of these tanks will be connected together to enhance the signal to noise ratio for cooling of pbars down to $1E7$ particles.

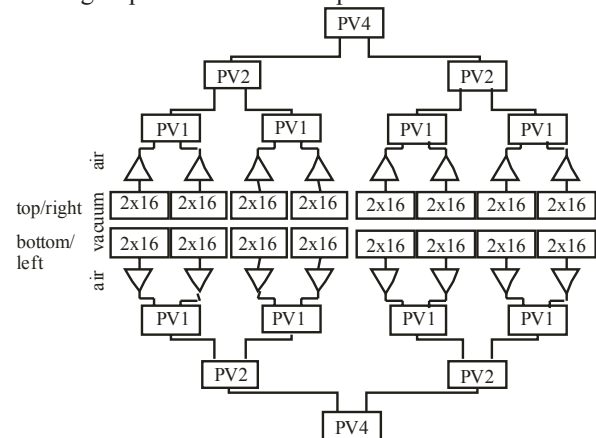

Figure 2: Double tank signal combination; PV1, PV2, PV4 programmable delay line including Wilkinson couplers.

The first active stage – the low-noise preamplifiers – will be outside the tanks and are commercially available. After this stage, the signal amplitudes will be high enough that additional losses by the programmable delay-lines don't affect the signal to noise ratio. The signal combination for each cooling plane takes place in 3 layers (Fig. 2). Hereby, switchable delay lines are required to compensate for the energy-dependent beam drift time. The delay lines will be switched in steps of 10 mm of electrical length at the first layer (PV1) and 20 mm at the further layers (PV2, PV4). The Wilkinson couplers, which combine two input signals after the switching stages, are already included. A deviation of 10 mm from the ideal length leads to a phase difference between the Wilkinson inputs that causes at 4 GHz an additional

attenuation of nearly 0.8 dB. The last Wilkinson layer adds the power of both adjoining tanks. This allows stochastic cooling in the whole energy range of the HESR (0.8 - 14 GeV). To minimize the number of switches, the reference plane is shifted at different energies but this can be easily compensated by adjusting the delay-line between pickup and kicker. Further, each signal-path of the delay-lines contains the same number of switches, and has therefore a similar amplitude-frequency characteristic. This reduces the expense of its compensation. Prototypes of each delay line were built and tested and fulfilled all RF requirements.

Transmission line from Pickup to Kicker

Pickups and kickers will be connected by 80m long transmission-lines one metre under the ground. The particle path length from the end of the pickup section to beginning of the kicker section is about 200m at the highest energy. Different types of transmission lines have been analysed, starting with solid air-filled coaxial lines, foam-filled coax cables and glass fibre cables to find the optimum solution regarding the attenuation, the temperature stability and most important the dispersion. Although the signal speed in a fibre is only 2/3 of the speed of light and additional lengths by the conversion systems has to be added, fibre links are the best choice for the connections from the pickups to the kickers. The TOF cooling (Time of Flight), which will be used besides the notch-filter cooling, requires a phase stability in the order of 10° at 4 GHz. Glass fibres have a typical temperature stability of about 30 ps/km/K. Thus a temperature change of +/- 1.5° in the transfer-line is tolerable. Larger changes will be compensated by an active length control similar to the one used for the notch-filter [6]. Hereby a pilot-signal – generated with a RF-source, which is synchronized by the FAIR BuTis system [7] – will be added to the fibre link and coupled out at the kicker side. A second BuTis synchronized RF-generator delivers the reference signal of the same frequency at the kicker side. Any temperature induced delay can be compensated just by comparing the phase change between these signals and driving a commercial optical delay line.

Since the stochastic cooling system will be used in the whole energy range of the HESR (0.8 – 14 GeV), each of the three signal paths requires adjustable delay lines up to a length of 40 m with steps not higher than 0.5 mm. Nowadays, programmable optical delay lines are commercially available without significant change of amplitude and dispersion. The same programmable delays in a classical design with RF-switches and semi-rigid lines would not only be very room consuming but also very complicate because of the active compensation of dispersion and amplitude.

Combiner-boards for pickups and splitter-boards for kickers

16:1 combiners, optimized for a best signal combination at the injection energy of 2.5 GeV ($\beta = 0.96$), join the electrodes in beam direction and built the smallest group without active change of signal delay. The combiner losses at lowest HESR energy and hereby the degradation of the signal-to-noise ratio are in the order of 2.5 dB which is still tolerable.

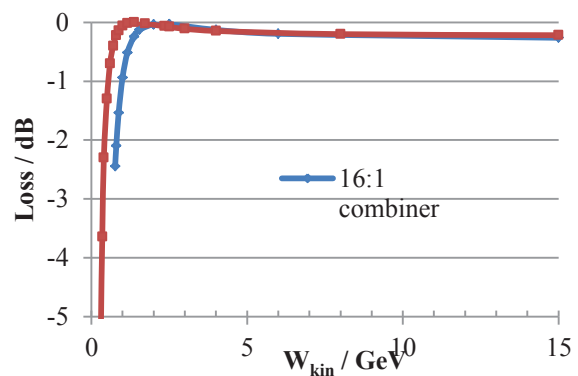

Figure 3: Losses of the 16:1 combiner compared to 8:1 combiner at different energies. The shown losses are upper limits occurring at 4 GHz.

Cooling at lower energies is only possible when the combiner will be halved (Fig. 3). But the possible lowest energy changes from 0.7 GeV to 0.38 GeV only, while the cost of the system will dramatically increase. The numbers of combiner-boards, vacuum feed-throughs, transmission lines, programmable delay-lines and low-noise pre-amplifiers will be doubled and the cryo-system needs modifications to deal with the additional heat load. Therefore the energy range will be kept fixed to the former range.

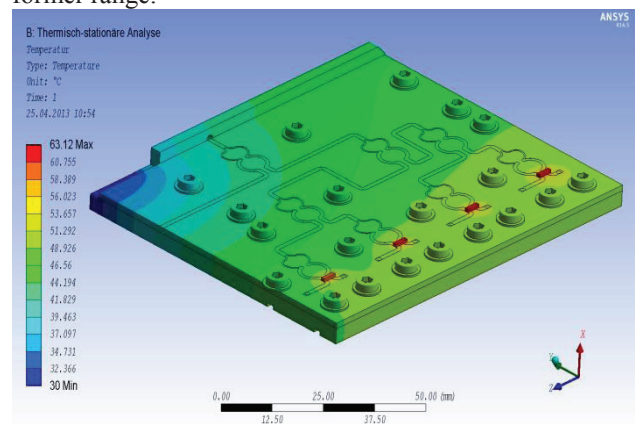

Figure 4: Simulation of temperature distribution caused by RF losses at the Wilkinson resistors, half a 1:16 splitter is shown.

Most of the RF-power fed through each kicker will be dissipated at the 1:16 splitter. Base material of these splitters is Al2O3 with a high thermal conductivity. Now

to prevent active water cooling inside the vacuum tank and to minimize the numbers of different combiner layouts, thermal simulations have been carried out to use the same pickup combiner-boards. The boards will be fixed with about 40 screws on the aluminium support plate. However the thermal conductance is too low for an indirect cooling of the Wilkinson resistors of the splitter boards. But the simulations show that a heat flow through the tank is possible when the boards are glued onto the support plate. The temperature at the Wilkinson resistors rises to a maximum value of about 65 °C only even at full RF-power (Fig. 4). First promising tests with heat conducting glue have been carried out.

Kicker section

The kicker section of the main stochastic cooling system consists of three equal kickers separated by some meters. Each kicker has the same structure as the pickup tanks, with 64 slot-coupler rings, PV1 and PV2 outside the tank for different energy settings, but without cryogenic installations.

The kickers are placed in the HESR according optimum phase advance, slip-factor and β -function.

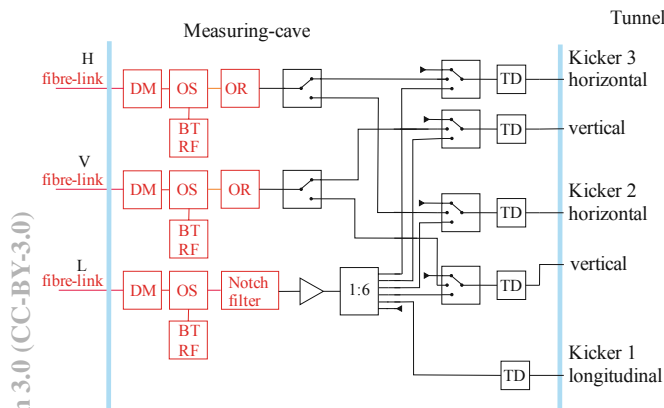

Figure 5: Kicker section of the main stochastic cooling system (2-4GHz) with signal switching; DM optical delay matrix, OS optical stretcher, OR optical receiver, BT RF BuTiS synchronized RF signal, TD tank delay.

While kicker 1 will be used for longitudinal cooling only, kicker 2 and kicker 3 can be used for all three cooling planes. During the accumulation of pbars [5] over 1000 seconds all kickers will operate in the longitudinal mode to reach the needed higher RF-power. A relay matrix will be used to switch between the different operations modes (Fig. 5). The path length for each cooling direction will be set by the optical delay matrix DM. The additional tank delays TD are needed for the high power longitudinal cooling during accumulation. These lengths will be measured once and fixed because accumulation takes place at injection energy only. This concept provides an installed RF power of about 250 W for each transverse cooling direction (horizontal/vertical) at each tank, or 500 W per tank when used for longitudinal cooling.

Just a few weeks ago, at the 20th March 2013, first stochastic cooling at the Nuclotron in Dubna was demonstrated (Fig. 6) [8]. It was the first time that the HESR structure was successfully used as kicker. We offer the Dubna-team congratulations on this huge success.

OUTLOOK

All drawings of the mechanical tanks are finished and the fabrication of the first pickup tank has started.

We hope to intensify the great collaboration with our colleagues from Dubna to optimize the system with real beam.

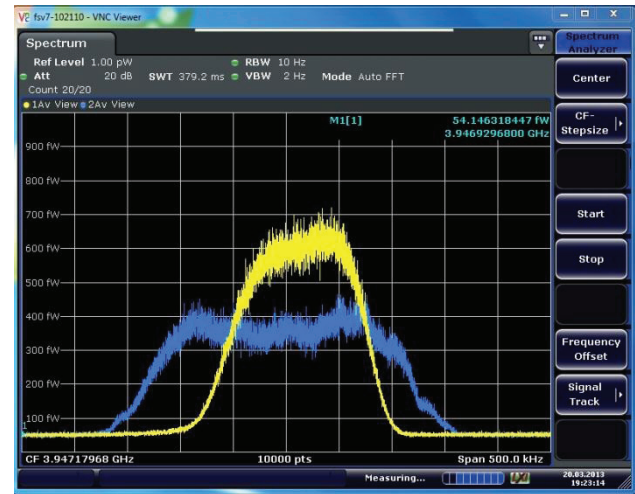

Figure 6: First stochastic cooling seen at the Nuclotron in Dubna: blue, beam distribution before cooling, yellow: after some minutes of cooling.

REFERENCES

- [1] L. Thorndahl, 90mm Full-Aperture Structures with TM01-Mode propagation for 6-8 GHz Stochastic Momentum Cooling in HESR, internal report, 2010
- [2] R. Maier, Cooler Synchrotron COSY – performance and perspectives, NIM A 390 (1997) 1-8
- [3] G. Trubnikov et al., Project of the Nuclotron-based ion collider facility (NICA) at JINR, Proceedings of EPAC08, Genoa, Italy, 2008
- [4] T. Katayama, T. Kikuchi, R. Maier, I. Meshkov, D. Prasuhn, R. Stassen, M. Steck, H. Stockhorst, Beam accumulation with barrier voltage and stochastic cooling, Proceedings of IPAC10, Kyoto, Japan, 2010
- [5] H. Stockhorst, R. Maier, D. Prasuhn, R. Stassen, Status of stochastic cooling Predictions at the HESR, Proceedings of IPAC11, San Sebastian, Spain, 2011
- [6] R. Stassen, F.-J. Etzkorn, G. Schug, H. Stockhorst, T. Katayama, RF and stochastic cooling system of the HESR, Proceedings of IPAC12, New Orleans, USA, 2012
- [7] P. Moritz, BuTiS – Development of a Bunchphase Timing System, GSI Scientific Report, 2009
- [8] G. Trubnikov et al, Status of the NICA project, this conference