

# IMPLEMENTATION OF A DIRECT LINK BETWEEN THE LHC BEAM INTERLOCK SYSTEM AND THE LHC BEAM DUMPING SYSTEM RE-TRIGGERING LINES

S. Gabourin, E. Carlier, R. Denz, N. Magnin, J. Uythoven, D. Wollmann, M. Zerlauth, CERN, Geneva, Switzerland  
 V. Vatansever, M. Bartholdt, B. Bertsche, P. Zeiler, Universität Stuttgart, Stuttgart, Germany

## Abstract

To avoid damage of accelerator equipment due to impacting beam, the controlled removal of the LHC beams from the collider rings towards the dump blocks must be guaranteed at all times. When a beam dump is demanded, the Beam Interlock System communicates this request to the Trigger Synchronisation and Distribution System of the LHC Beam Dumping System. Both systems were built according to high reliability standards. To further reduce the risk of incapability to dump the beams in case of correlated failures in the Trigger Synchronisation and Distribution System, a new direct link from the Beam Interlock System to the re-triggering lines of the LHC Beam Dumping System will be implemented for the start-up with beam in 2015. The link represents a diverse redundancy to the current implementation, which should neither significantly increase the risk for so-called asynchronous beam dumps nor compromise machine availability. This paper describes the implementation choices of this link. Furthermore the results of a reliability analysis to quantify its impact on LHC machine availability are presented.

## INTRODUCTION

The two main systems of which the correct functionality is required for reliably extracting the LHC beams are the Beam Interlock System (BIS), which transmits the dump request, and the LHC Beam Dumping System (LBDS), which receives this request and executes the extraction of the particle beams.

Despite the multi-redundancy within the LBDS, a single type of electronic board is used for transmitting the request. To have more redundancy and overcome potential issue on the existing electronics, a new type of electronic will supply a parallel dump request, directly from the BIS to the retriggering lines of the LBDS.

## BIS AND LBDS PRESENTATION

### LHC Beam Interlock System

The Beam Interlock System (BIS) [1] is responsible of transmitting the Beam Permit all along the LHC. Four (two per beam) redundant Beam Permit loops made of optic fibres are installed in the machine (see Fig. 1). The Beam Permit is a signal produced by a square-wave generator located in Point 6, near the Dumping System. The Beam Permit loops pass by 17 Beam Interlock Controllers (BIC) which have the capacity to stop the

Beam Permit signal. The BICs are scattered in the machine to gather locally the Boolean User Permits provided by User Systems. These User Permits connect in a logical AND inside the BIC to build its Local Permit, which, if it is true, allows the Beam Permit transmission to the next BIC.

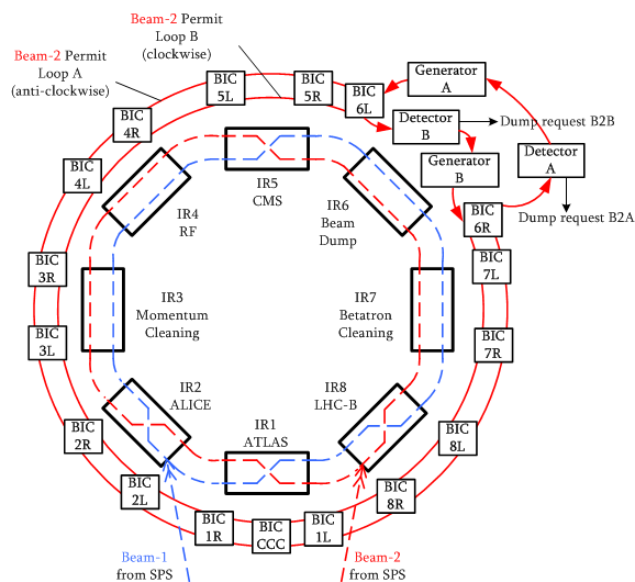

Figure 1: BIS layout for Beam 2.

A detector is inserted at the end of each loop to verify whether the Beam Permit signal is still present. If not a beam dump will be executed.

### LHC Beam Dumping System

The magnets of the LHC beam dumping system [2] consist of 15 pulsed extraction kicker magnets, 15 DC septum magnets and 10 pulsed dilution kicker magnets per beam. Once the beam dumping system is triggered by the BIS CIBM, see fig. 2, the Trigger Synchronisation Unit (TSU) synchronises the pulsed magnets with a 3 μs particle free abort gap in the beam. This prevents that the extracted beam is swept through the machine aperture instead of travelling through the beam dump extraction line. The TSU also sends a trigger pulse to the retriggering system, after applying a delay of 200 μs.

The Trigger Fan Out (TFO) distributes the trigger pulse, applying the correct delays, between the Power Trigger Units (PTU) of the different extraction and dilution kicker magnets.

Content from this work may be used under the terms of the CC BY 3.0 licence (© 2014). Any distribution of this work must maintain attribution to the author(s), title of the work, publisher, and DOI.

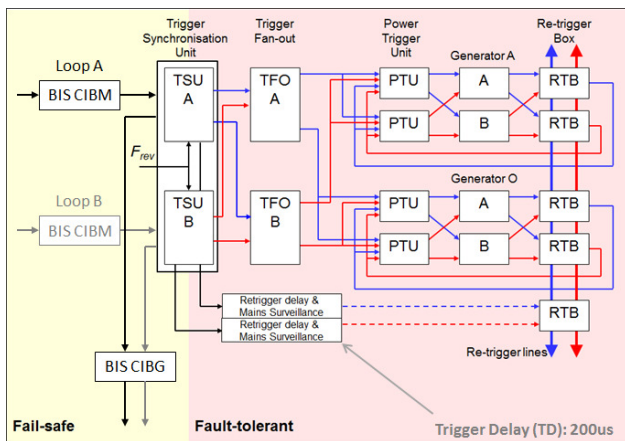

Figure 2: LBDS layout for one Beam.

As shown in fig. 2 there is a large cross redundancy at the level of the connection between BIS and TSUs, between the TSUs and the TFOs, between the TFOs and the PTUs and the connection of the PTUs and the pulsed magnet generators.

## IMPLEMENTATION OF THE LINK

### Principle

Figure 3 shows the principle of a Beam Permit Loop. The electronics board in charge of generating the signal is called CIBG and the one in charge of managing the User Permits and controlling the state of the loop are called CIBM.

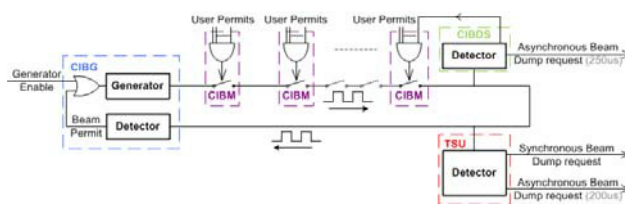

Figure 3: New CIBDS into a Beam Permit Loop.

The new link consists on the addition of a new BIS electronic board called CIBDS into the Beam Permit loop. It works in parallel of the TSU in order to ensure a dump is requested on a complete independent way. The CIBDS can only read the Beam Permit (without interrupting it), detect when it is lost, then trigger a dump without passing by the TSDS, but directly to the retriggering lines of the LBDS.

### Hardware

The CIBDS is a VME-based electronic circuit board based on the CIBM design and keeping the philosophy of separation between the critical and monitoring parts. Each critical redundant channel has its own electronics components, including a CPLD. The monitoring part, communicating by the VME bus with the supervision, is managed by a separated FPGA.

## Operation

In normal operation, the dump request (DR) is taken into account by the TSU synchronously with the Beam Revolution Frequency (BRF) pulse. In case of a failure of this redundant link, an asynchronous beam dump request (RETRIG) is made, also by the TSU. As up to 90  $\mu$ s (one beam turn) can be necessary to start a synchronous beam dump (SBDT), the asynchronous one is delayed by 200  $\mu$ s to ensure it occurs afterward. The CIBDS board, which is not synchronized with the BRF, generates an asynchronous dump request, which has to be taken into account only if all other requests of the TSU fail. For this reason, and to distinguish it from the TSU triggers, it is delayed by 250  $\mu$ s, as shown in Fig. 4.

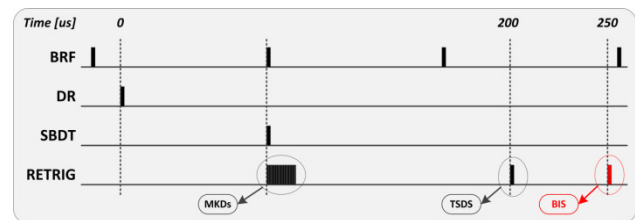

Figure 4: Timing of dump requests.

Once in operation, it is mandatory to check that for every dump of the machine, the asynchronous dump request of the CIBDS occurs effectively 250  $\mu$ s after the DR. This check will be automatically executed by the Internal Operational Check (IPOC) system and External Operational Check (XPOC) system. The latter will prevent the beam from being injected in case a failure is detected.

A synchronous dump is always preferable to an asynchronous one to avoid generating particle showers downstream of the extraction kickers leading to a possible quench of the downstream magnets. Despite the low probability to get spurious triggers of the CIBDS, its dump trigger is logically inverted to provide a User Permit to the closest CIBM. In case the CIBDS induces a false dump, its User Permit going to false makes the CIBM opening the Beam Permit loop. Considering the TSU is working normally, a false SBDT is produced and the asynchronous dump avoided.

Another feature of the CIBDS is the capacity to inhibit its dump request in case the LBDS is in Test Mode (or Local Mode) during commissioning or Machine Development phase. To strongly ensure the dump request will never be inhibited during normal operation, the Local Mode is provided with complete redundancy from the PLC of the LBDS to the CIBDS, including cabling. System failures (like an unplugged cable) make the CIBDS falling into its fail-safe mode (normal beam operation). Moreover the Local Mode is read back by the PLC of the LBDS which will ask for a dump if any inconsistency is detected.

## RELIABILITY STUDY

To quantify the impact on the LHC operation of the Direct Link between the BIS and the LBDS, a Reliability Analysis was carried out. It investigates false beam dumps caused by the CIBDS' and the connected 250  $\mu$ s Trigger Delay Units (TDUs) [3]. The analysis considers failure rate data from the component manufacturers and calculated failure rates based on Military Handbook 217F [4].

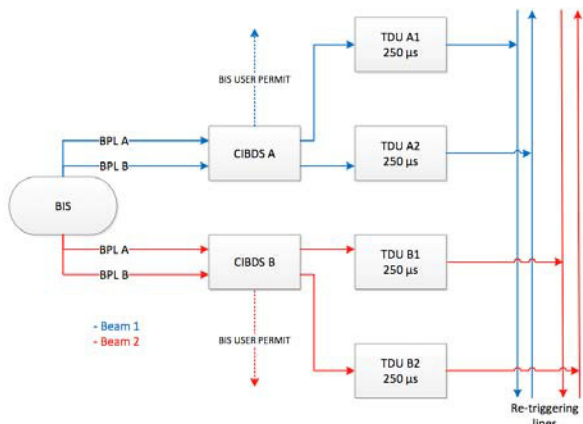

Figure 5: Installation of the Direct Link.

Figure 5 shows the installation and signal distribution of the CIBDS and the TDUs. Two CIBDS' are connected to four TDUs, which will trigger the Re-triggering lines.

The effects of a component failure in these units were derived from a Failure Mode and Effects Analysis. The predictions show, that in ten years of LHC operation  $19.7 \times 10^{-3}$  asynchronous beam dumps and  $54.5 \times 10^{-3}$  synchronous beam dumps can be expected.

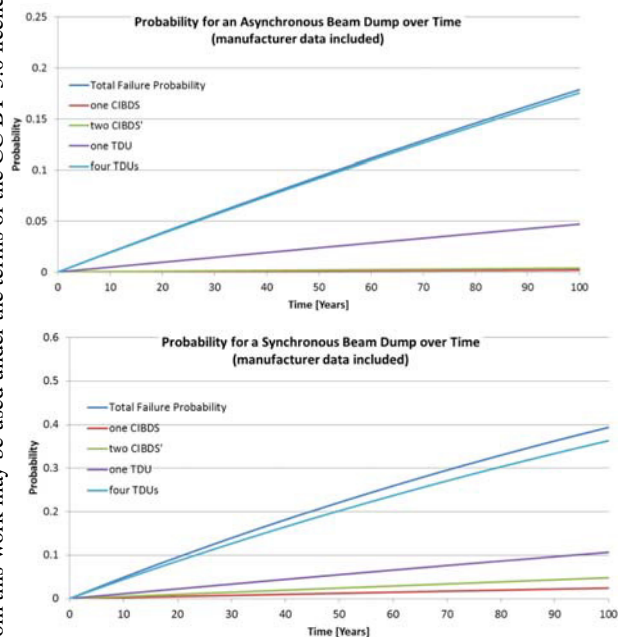

Figure 6: Probability for beam dumps over time.

Figure 6 shows the probability for beam dumps over time for the CIBDS', the TSUs and the system implementation, which considers the hardware boards and the connections between them. The probability for an asynchronous beam dump in ten years of operation is predicted to be ~2%, whereby the contribution of the CIBDS boards to this failure mode is almost negligible. A synchronous beam dump within the same time period can be expected with a probability of less than 10%.

## CONCLUSION

To reinforce the capacity of the LBDS to extract beams, a new link is implemented for the restart of the LHC in 2015. This link connects the BIS directly to the retrigger lines of the LBDS, without interaction with the TSUs.

A careful study of this link was made in parallel of its implementation to ensure its reliability and to avoid false dumps. The results of the study show probabilities of failures much below the ones requested by the functional specification.

Two CIBDS boards are installed in the LHC since May 2014. The boards work as expected and during preliminary testing, no faults have been revealed so far.

## REFERENCES

- [1] B. Puccio, A. Castañeda, M. Kwiatkowski, I. Romera, B. Todd, "The CERN Beam Interlock System: Principle and Operational Experience", IPAC'10 Kyoto, Japan, May 2010, <http://www.JACoW.org>
- [2] The LHC Design Report: "The LHC Main Ring", Vol. 1, Chap 17 "Beam Dumping System", CERN, Geneva 2004, CERN-2004-003-V-1
- [3] V. Vatansver, "Reliability analysis of the new link between the beam interlock system and the LHC beam dumping system", Diplomarbeit Uni Stuttgart, IMA2014-ZU-14, 2014. Also CERN edms 1372314.
- [4] Department of Defense. Reliability Prediction of Electronic Equipment - MIL-HDBK- 217F-N2. Washington DC, USA : Department of Defence, 1995.

Content from this work may be used under the terms of the CC BY 3.0 licence (© 2014). Any distribution of this work must maintain attribution to the author(s), title of the work, publisher, and DOI.