

# OPTIMIZATION OF LOW ENERGY ELECTROSTATIC BEAM LINES\*

O. Karamyshev, D. Newton, C.P. Welsch<sup>#</sup>  
 Cockcroft Institute and The University of Liverpool, UK

## Abstract

Electrostatic elements are frequently used for transporting low energy charged particles, as they are easy to build and operate. However, beam motion is strongly affected by effects from fringe fields, positioning and manufacturing errors of individual ion optical elements. It is important to carry out detailed studies into these effects in order to optimize beam transport. In this paper results from numerical studies with a purpose-written code are presented and compared against analytical estimates. It is shown how the results can be used to optimize the mechanical layout of the electrostatic ion optics elements, including quadrupoles and spherical deflectors. Finally, the results from beam tracking through a multi-element beam line are presented on the basis of both, matrix multiplication and numerical particle tracking.

## INTRODUCTION

ELENA is a compact storage ring [1,2] for cooling and further deceleration of 5.3 MeV antiprotons delivered by the CERN Antiproton Decelerator to 100 keV final energy. The ELENA transfer lines will then transfer the low energy anti-proton beam from the ring to eight different experiments that are installed in the AD hall [3]. Due to the low beam energy of 100 keV it was decided to base the beam line on electrostatic ion optical elements. The goal of numerical studies into the beam line was to address the following tasks:

- Create models of all elements of the ELENA beam transport lines;
- Track particles through electrostatic fields of the individual elements;
- Determine the transport matrix of each individual elements on the basis of the numerical model;
- Track particles through realistic beam lines.

The ELENA beam lines consist of 5 different types of electrostatic elements: There are 3 static spherical deflectors with deflection angles of 33°, 47° and 77°, respectively, a fast kicker that is used for switching between the beam lines, often used in combination with the static deflector. This kicker is designed to move the beam quickly away from the axis by 220 mrad. Finally, electrostatic quadrupoles are used to provide beam transport and shaping. [4]. Models of all these elements have been built in Comsol Multiphysics on the basis of CAD drawings of the elements. Before import into the Comsol environment these were stripped of all details that are irrelevant for field calculations, such as screws, etc. In addition, the model was optimized to increase the accuracy of the simulated field in the fringe field areas.

\* Work supported by the STFC Cockcroft Institute Core Grant No. ST/G008248/1.

<sup>#</sup>oleg.karamyshev@cockcroft.ac.uk

## CODES AND METHODS

In order to achieve better accuracy in the simulation as compared to what Comsol can achieve by itself a purpose-written code for particle tracking has been developed using the Matlab Simulink environment [5]. This code is able to carry out calculations on the basis of field maps originating from different sources including other codes and experimental data and provides access to highly accurate tracking. The code can also be used to set up different types of beams by defining the distribution as an input parameter. By tracking the beam through individual elements of the beam line it is then possible to derive transport matrices of all elements.

Fields for the ELENA beam lines were calculated in Comsol Multiphysics. Models are initially calculated without taking into account any symmetry aspects of the ion optical element, thereby providing a way to check the quality of the field maps. Different techniques are then applied to improve the quality of the field map in the beam region. 2 different beam types are used, a hollow beam and a Gaussian beam.

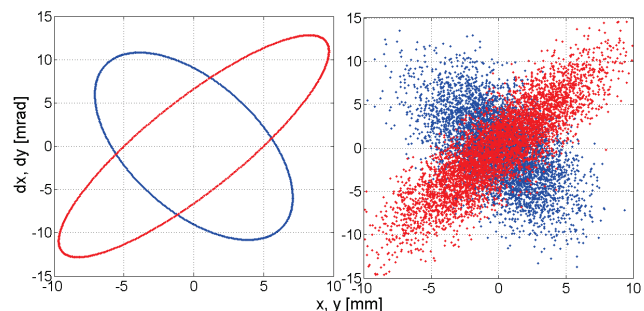

Figure 1: Hollow and Gaussian beams with otherwise identical beam parameters.

For the purpose of calculating the transfer matrices the effects from fringe fields were taking into account up to a maximum extend of 0.1 m before and after the individual electrostatic element. After tracking the particles through the element the transport matrix of the element is calculated, including the bending angles for the deflectors and the kicker. On the basis of the coordinates and velocities of each particle of the beam at each moment of time one can then calculate the transport matrix by solving the following equation:

$$\begin{pmatrix} x'_1 \\ x_1 \end{pmatrix} = T * \begin{pmatrix} x'_0 \\ x_0 \end{pmatrix}$$

where  $x_{0,1}$  and  $x'_{0,1}$  denote the particle's initial/final position and angle and T the transfer matrix. For N particles this yields a system of 2\*N equations with only 4 variables, i.e. an over-specified problem. However, particle tracking through numerically calculated fields

Content from this work may be used under the terms of the CC BY 3.0 licence (© 2014). Any distribution of this work must maintain attribution to the author(s), title of the work, publisher, and DOI.

always contains errors, so increasing N leads to a serious increase of the accuracy of the solution. In addition, the Twiss parameters  $\alpha, \beta$  and  $\gamma$  of the beam have to satisfy the following condition:

$$\begin{pmatrix} \beta & -\alpha \\ -\alpha & \gamma \end{pmatrix} = T \times \begin{pmatrix} \beta_0 & -\alpha_0 \\ -\alpha_0 & \gamma_0 \end{pmatrix} \times T^{-1}$$

These are calculated by fitting an ellipse in the case of the hollow beam or by fitting a Gaussian distribution for the Gaussian beam. Using these two different methods has shown to yield better accuracy in determining the Twiss parameters. Combining these different aspects improves the transport matrix calculation noticeably.

## QUADRUPOLE

The creation of an adequate simulation model and tracking of the beam through it consists of several steps: First, a model is created in Comsol by importing a CAD file, see Fig. 2, and removing all unnecessary elements as outlined before. Second, voltages are applied on all electrodes and the model is being meshed with very accurate, less than 0.5 mm grid size, mesh in the centre, where the beam will be passing. Third, the model is solved and checks are being carried out for errors, creating an array of voltages and electric fields which can then be exported to Matlab, see Fig. 3. After applying suitable symmetry conditions and smoothing the field map to get rid of any errors caused by the finite size of the mesh in Comsol, tracking can be done.

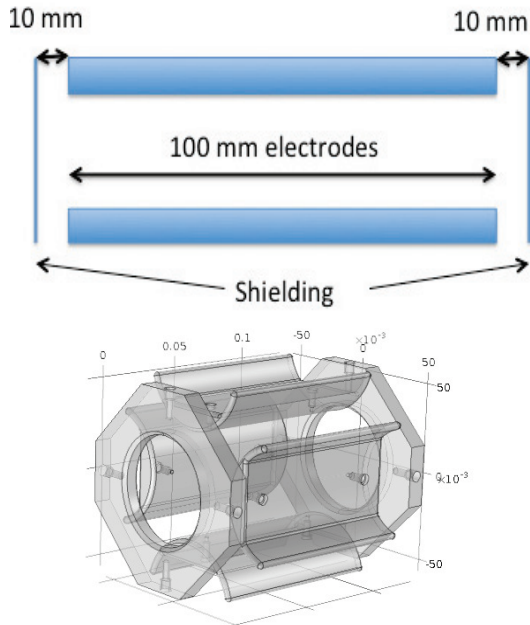

Figure 2: Quadrupole model in Comsol.

In a next step the resulting transport matrices are multiplied by inverse matrices of the drifts from both sides to obtain a transport matrix of the whole quadrupole with an effective length of 100 mm to correspond to a hard-edge quadrupole. The focusing strength K and effective length L for both, the defocusing and focusing planes, was calculated and results are presented in Fig. 4.

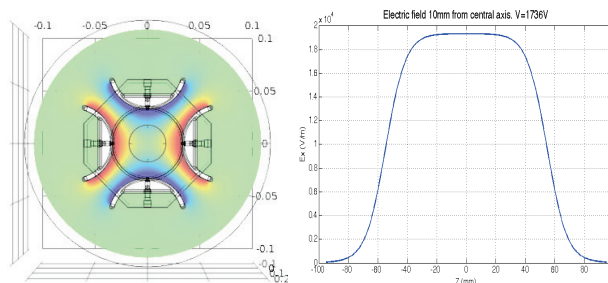
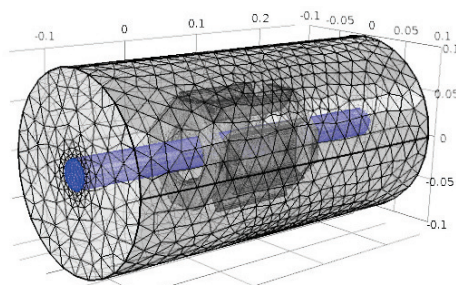

Figure 3: Meshed model, potential distribution and electric field.

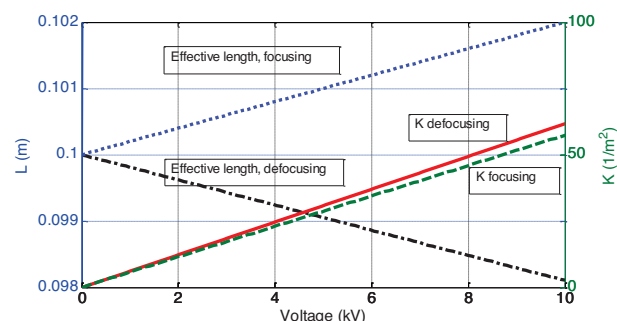

Figure 4: Focusing strength K and effective length L of the quadrupole.

## BENDING ELEMENTS

For the electrostatic bending elements the same approach was adapted as for the quadrupole. Each deflector is an electrostatic spherical deflector with an inner radius of 470 mm and outer radius of 530 mm, see Fig. 4. For a 100 keV antiproton beam the default voltage between the plates is 24 kV. The deflectors have shielding plates situated 15 mm from the edges of their electrodes. Due to the fringe fields the deflection angle will not be the same as the mechanical angle of the electrodes. By using a detailed numerical model one can fine-adjust the voltages required for specific deflection angles.

As an example, the results from particle tracking through a 47° deflector are presented in Fig. 6.

In this case the effective deflection is 47.84°. Thus to turn the beam by exactly 47° one has to apply 11.71 kV onto the electrodes, rather than the 12 kV that would be required for a hard-edge electrode.

Fig. 7 shows the horizontal/vertical phase space ellipse (small/large black ellipse) before the bend and after the bend (blue/red). Voltages and transport matrices were calculated for all three deflector types and the results are presented in Table 1. For a hard-edge model the transport

Content from this work may be used under the terms of the CC BY 3.0 licence (© 2014). Any distribution of this work must maintain attribution to the author(s), title of the work, publisher, and DOI.

matrices in both planes are identical. One can see that in particular in the bending plane the difference between a hard-edge model and tracking matrices is quite high.

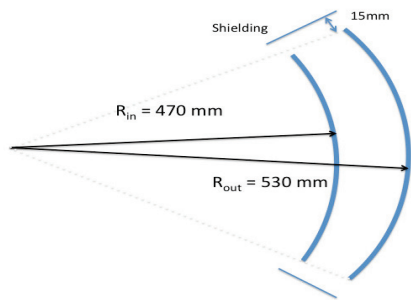

Figure 5: Schematic drawing of an electrostatic bending element.

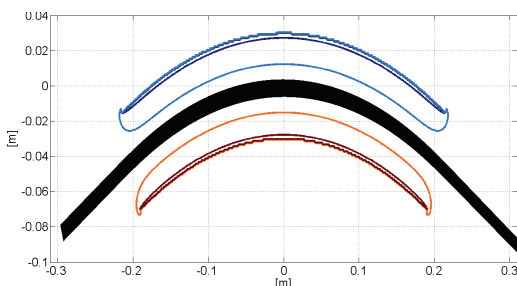

Figure 6: Particle trajectories in a 47° deflector.

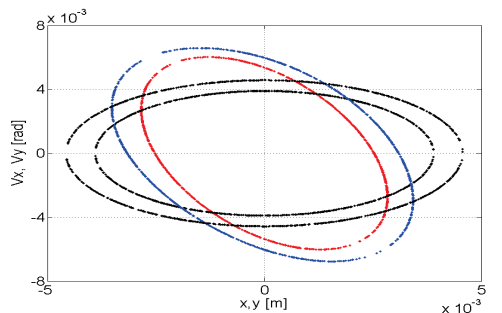

Figure 7: Beam ellipses 0.1 m before and after the bend.

Table 1: Parameters of the Deflectors

Deflector 1		Deflector 2		Deflector 3	
77.4°		47.84°		34.37°	
11,830 V		11,710V		11,620V	
Transport matrices in horizontal (turning) plane:					
0.078	0.529	0.575	0.501	0.754	0.444
-1.875	0.078	-1.340	0.575	-0.970	0.754
Transport matrices in vertical plane:					
0.035	0.516	0.5346	0.4931	0.7225	0.4385
-1.937	0.035	-1.4482	0.5349	-1.1094	0.7725
Hard-edge model					
0.0231	0.5121	0.5230	0.4901	0.7126	0.4361
-1.9516	0.0231	-1.4823	0.5230	-1.1288	0.7126

## BEAM LINE TRACKING

Tracking through the whole beam line is a very complex task. In order to limit computation time, the beam line needs to split into its individual parts. Tracking through the whole line is then realized by tracking particles through each element and then use the resulting (new) start coordinates as a basis for tracking through the next element. This way, tracking through very large beam lines can be achieved and Fig. 8 illustrates this through a kicker and bending element assembly.

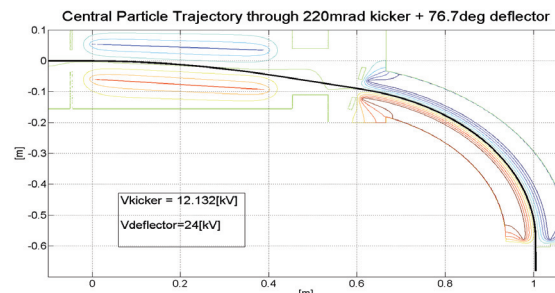

Figure 8: Tracking through a kicker and bending element assembly.

Benchmarking studies showed that the results from beam tracking and the ones obtained from product matrices combining several elements were in excellent agreement.

## CONCLUSION

In order to provide a basis for detailed simulation studies into the beam dynamics of low energy beam lines with an initial focus on the electrostatic beam transport lines from the ELENA ring to external experiments a simulation framework based on Comsol Multiphysics, supported by purpose-written Matlab code has been developed. Here, the steps involved in providing realistic high resolution models of all ion optical elements were presented in detail. The obtained transfer matrices were compared against simple hard edge models and show the additional information and accuracy that can be obtained via this route. Finally, beam tracking through realistic beam line elements was performed and the potential for optimization studies using this framework shown.

## REFERENCES

- [1] [espace.cern.ch/elena-project](http://espace.cern.ch/elena-project).
- [2] V.Chohan, et al., 'Extra Low ENergy Antiproton (ELENA) ring and its Transfer Lines: Design Report', CERN-2014-002, (2014).
- [3] G. Vanbavinckhove et al., "Geometry and optics of the electrostatic ELENA transfer lines", Proc. IPAC2013, Shanghai, China (2013), p. 1985.
- [4] D. Barna et al. "Field Simulations and Mechanical Implementation of Electrostatic Elements for the ELENA Transfer Lines", Proc. IPAC14, MOPRI101, Dresden, Germany (2014).
- [5] O. Karamyshev, et al., "Optimization of Low Energy Charged Particle Beam Transport", Proc. IPAC14, MOPME029, Dresden, Germany (2014).