

THE LHC VACUUM PILOT-SECTOR PROJECT

B. Henrist#, V. Baglin, G. Bregliozzi, and P. Chiggiato, CERN,
Geneva, Switzerland

Abstract

The operation of the CERN Large Hadron Collider (LHC) at nominal beam parameters is expected for the next years (2015). Increased synchrotron-radiation stimulated-desorption and electron-cloud build-up are expected. A deep understanding of the interactions between the proton beams and the beampipe wall is mandatory to control the anticipated beam-induced pressure rise. A Vacuum Pilot Sector (VPS) has been designed to monitor the performance of the vacuum system with time. The VPS is installed along a double LHC room temperature vacuum sector (18 m long, 80 mm inner diameter beam pipes) and includes 8 standard modules, 1.4 m long each. Such modules are equipped with residual gas analysers, Bayard-Alpert gauges, photon and electron flux monitors, etc. The chosen modular approach opens the possibility of studying different configurations and implementing future modifications. This contribution will describe the apparatus, the control system designed to drive measurements and possible applications during the next LHC operational phase.

INTRODUCTION

Electron cloud can be one of the main limitations for the next operational phase in the LHC [1]. Increasing beam intensity up to $2.2 \cdot 10^{11}$ p/b and decreasing bunch spacing to 25 ns, a growth of the electron flux impinging the vacuum beampipe walls is expected. In addition, protons at energies up to 7 TeV will emit more synchrotron radiation, which in turn generate more photoelectrons so that electron multipacting phenomena will be even more problematic than in the previous operational phase.

Installed in the room temperature areas of the LHC, the Vacuum Pilot Sector (VPS) will allow monitoring the scrubbing and cleaning run planned at the beginning of the LHC restart, after the long shutdown 1 [2, 3]. In addition, the VPS will allow studies of new surfaces, coatings, and chemical treatments aiming at improving the LHC beam performance.

LOCALISATION

The VPS is installed on the left side of the interaction point 8 where the LHCb experiment is installed. This position allows the use of relatively short cables to connect the electronic racks and does not expose electronics to the radiation of the LHC tunnel (see Figure 1). The area of installation is a double vacuum sector (two separated beams) about 18 m long and, originally, made of standard drift 80 mm ID vacuum chambers.

#Bernard Henrist@CERN.ch

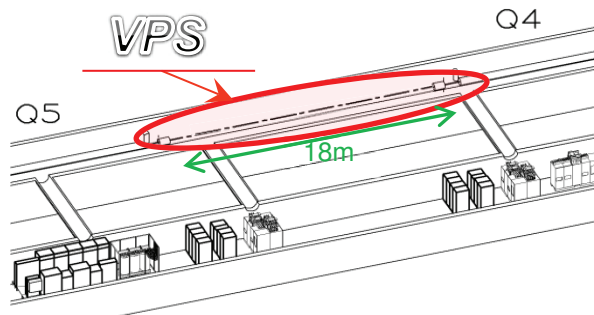

Figure 1: Position of the VPS (in vacuum sector A5L8) between the quadrupole Q4 and Q5, close to the services gallery.

Only one of the two beamlines is irradiated by synchrotron radiation coming from the LHC arc. This difference between the two parallel sectors gives the opportunity to compare the behaviour of different materials with and without photon flux hitting the surfaces.

STATIONS

Four places have been chosen along the sectors to install dedicated detectors. The symmetry is kept everywhere to be able to compare the results on both lines. Each station is composed of two parallel opposite vessels with similar equipment. However, each station could have different surface materials under test and possibly different apparatus. A strong pumping must be installed between each station to limit gas transfer from one to the other. This is achieved by the use of 2 m long NEG coated beam pipes and ion pumps installed on both side of each station.

Figure 2 shows the expected pressure profile along the vacuum sectors in different conditions. The simulations are performed with the VASCO code, a tool to study gas density distribution developed at CERN [4]. For such a computation, a constant and distributed electron flux of $1 \cdot 10^{16}$ [e-/m/s] is applied all along the beam pipes. The configuration was optimised in terms of lowest interaction between modules by testing different material surfaces. Based on the calculated pressure profiles, it was decided to install the following experimental stations, all equipped with detectors: NEG coating activated at 230°C (24h); NEG coating only baked at 120°C (24h); unbaked copper representing the surface in the LHC arc; and finally copper baked at 250°C (24h). The unbaked station will be kept at temperature around 80°C during the bake-

out of the rest of the sectors so as to minimize possible local gas condensation.

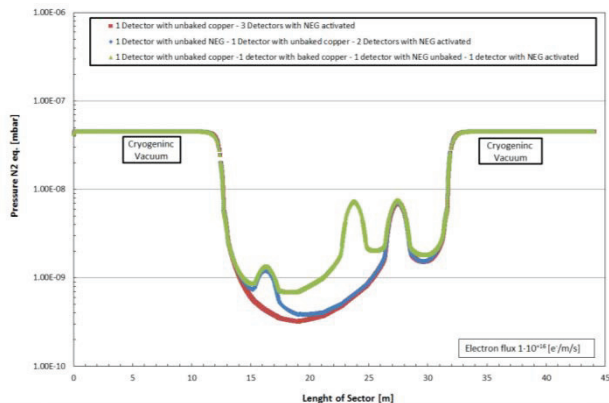

Figure 2: VASCO simulation of the pressure profile of the VPS for 3 different configurations during electron multipacting. The red curve shows one station on the right with unbaked copper. The blue one adds an unbaked station on the left side and the green adds a second unbaked copper station in the middle.

VACUUM VESSEL AND LINERS

For impedance and aperture reasons, the nominal diameter of the beam pipe seen by the beam must be kept constant to 80 mm. To avoid the need of anti-chambers, to mount the detectors a larger vessel is used in which 80 mm diameter liners are inserted (see Figure 3). Such a liner must be correctly grounded at each extremity to have an electrical continuity and let the image current of the proton beam passing through it. The in vacuum cabling is made of insulated kapton coaxial cables ended with SMA connectors to be 50Ω matched.

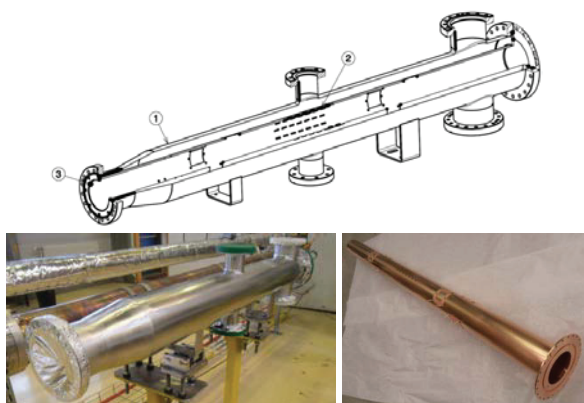

Figure 3: VPS vacuum vessel (one of the two lines of a station).

The use of liners gives the opportunity to exchange them easily with new ones to study different surface treatments and materials.

PRESSURE MEASUREMENTS

The central zone of the liners is perforated with slots (84 holes of 12x3 mm section) for gas analysis purpose.

The central ports are equipped with gas analysers and hot cathode vacuum gauges.

The use of a residual gas analyser (RGA) in particles accelerators is often a source problem because of radiation damage. The RF supply of standard quadrupole RGA is usually not radiation resistant and the length of the cables is limited to some meters. For this reason, an Autoresonant Trap Mass Spectrometer (ARTMS) is used, allowing the installation of the sensitive electronic to more than 50 m away, in a radiation free area [5].

OTHER TYPE OF MEASUREMENTS

Eight square windows are available in each liner to install different type of detectors. The windows that are not used are fit with a blind patch. Electron flux measurements can be done with a pile of grids and electrodes to collect or reject a part of the electrons extracted from the beam pipe as shown in Figure 4.

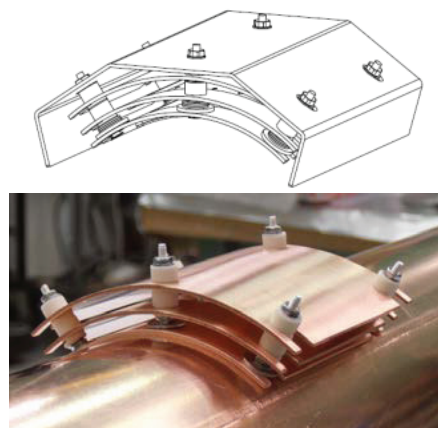

Figure 4: Electrodes mounted on the liners. Top: a retarding field analyser. Down: a picture taken during the installation (without the last screen).

Calorimetric measurement can be also done. The calorimeter is made of a thin copper plate, equipped with pt100 gauges and fitted to the liner with some stainless steel thin ribbons. Since the stainless steel is a bad thermal conductor and a good electrical conductor, the copper plate will be thermally insulated from the liner. The image current will be able to flow in the ribbons and the copper with a negligible Joule effect. After calibration, it is possible to calculate the power deposition on the copper plate by an analysis of the temperature variations.

A biased gold coated pick up will serve as a photoelectron current monitor in such a way to estimate the photon flux along the liners.

MODULARITY

Modularity is one of the main objectives of the VPS. Many studies could be performed in the future to further qualify vacuum surfaces [6]. The high modularity should

help exchange apparatus and cabling easily during short-time interventions.

REMOTE CONTROL

One of the major differences with respect to previous measurements done in other CERN accelerators is the absence of remote control in a control room at the ground [7]: it is not possible to access the control system when the beams are running. Remote control through the network was chosen to perform the measurements. Two remote computers are installed in the service gallery in a radiation free area to be able to monitor and control the different devices. A remote 2 GHz oscilloscope is used to monitor the beam structure. A low current multiplexer, using 20 lines, measures the pickup's signals during the run (Keithley 7001, 7158 and 6485). A data acquisition switch-unit monitors the temperatures of the calorimeter (HP 34970A). Different types of supplies feed solenoid coils around the chambers to suppress the multipacting, and set variable tensions on grids in the retarding field detectors to estimate the electron energy spectrum. The signals will be recorded during the proton run to follow the behaviour of the different surfaces.

LHC RUN 2

The four stations described above are installed for the next LHC operational phase. Each station will have a 7% transparency pickup on the up position to record the electron activity with time. Pressure, gas composition and beam parameter will be monitored as well for reference. The symmetry of the station should give the possibility to compare the activity of the line receiving the photons from the arc and the other one. Pickup with grids of different transparencies (5% and 10%) will be added to check the influence of the electron extraction from the cloud. Two other pickups, assembled on the side will check if the phenomenon is radially homogeneous. The retarding field analyser will be used to estimate the energy spectrum of the electron cloud. The calorimeter will record the temperature variation of a copper plate exposed to the beam to deduce the power deposition on the surface. Finally, a system will do a fast extraction of

the low energy electrons suspected to be present in the chamber just after the passage of a proton batch.

However, due to cabling modification, it will not be possible to do all the measurements at the same time. Some dedicated interventions will be needed to modify the connection scheme without venting the systems.

CONCLUSION

The VPS is designed to become a multitask set-up to study beam-surface interaction in the LHC with nominal beams. Since the beginning of the study, the VPS has been intended as an evolutionary system to facilitate future upgrades. In parallel, other stations will be installed in the laboratory to prepare the next generation of detectors to be installed at the next shutdowns.

ACKNOWLEDGMENT

The authors would like to thanks: the group EN-MME for the support during the design and procurement; the BE-RF and BE-BI groups for their help, recommendations and support.

REFERENCES

- [1] G. Iadarola et al., 3rd Joint HiLumi LHC-LARP Annual Meeting 2013, Daresbury Laboratory, Daresbury, November (2013).
- [2] G. Iadarola et al., Proceeding of IPAC2013, Shanghai, China.
- [3] F. Bordry et al., Proceeding of IPAC2013, Shanghai, China.
- [4] G. Bregliozzi et al., Vacuum, 2012; 86, 11: 1682-1687.
- [5] S. Lass, Brooks Automation, OLAV IV Presentation, Taiwan, April (2014).
- [6] P. Costa Pinto et al., Joint INFN-CERN-EuCARD-AccNet Workshop on Electron-Cloud Effects La Biodola, Isola d'Elba, Italy, 5 - 9 Jun 2012, pp.141-148.
- [7] J. M. Jimenez et al., Proceeding of PAC'03, Portland Oregon.