

VACUUM CONTROL SYSTEM UPGRADE FOR ALPI ACCELERATOR

G. Savarese, L. Antoniazzi, D. Bortolato, INFN/LNL, Legnaro (PD), Italy
A. Conte, F. Gelain, D. Marcato, C. Roncolato, INFN/LNL, Legnaro (PD), Italy

Abstract

The vacuum system of ALPI accelerator includes about 40 pumping groups based on turbomolecular pumps. The instrumentation of the accelerators complex is mainly the one installed in 90s, with consequent maintenance issues. The control and supervision systems were developed in the same period by an external company, which produced custom solutions for the HW and SW parts. Control devices are based on custom PLCs, while the supervision system is based on C and C#. The communication between the field and the supervisor is composed of multiple levels: RS-232 standard is used to transfer control parameters from the field devices up to custom multiplexers; RS-485 transmission is used from the multiplexers to two PC servers covering different sections of the installation; while Ethernet, is used to connect the servers and the operation console. Obsolescence and rigidity of the system, deficit of spare parts and impossibility of reparation or modification without external support, required a complete renovation of the vacuum system and relative controls in the next years. This paper describes the adopted strategy and the implementation status.

INTRODUCTION

The legacy ALPI-PIAVE Vacuum Control System (VCS) was developed in '90s by TELEMA company [1]. TELEMA was also in charge of maintaining and upgrading the hardware and the software. The obsolescence of the system already required the planning of an hardware replacement, which is still on-going [2]. Since at the end of 2021 TELEMA closed its business, the control system group made an immediate evaluation of the VCS software and hardware status and decided to replace as soon as possible the software [3], written in C/C#, with an EPICS [4] based control system, compatible with the existing hardware, which will be expanded to communicate with the new hardware in development.

We chose this solution for the following reasons:

- The legacy software is written in a language not used by the control system group, and it is the result of several updates not always documented or well commented. To develop an EPICS based control system from scratch will ease the software maintenance
- A working solution in a short time is required for machine protection reason and we don't have spare hardware; the control hardware should remain untouched as much as possible. EPICS IOCs creation is relatively quick, simple and adaptable to the current hardware architecture.

- The development of a new EPICS supervisor, backwards compatible, that will substitute the legacy one, was already planned.

STATE OF THE ART

Different hardware and software versions of the TELEMA Vacuum Control System (VCS) exist at the same time, but the project architecture is the same; the difference mainly impacts the controllers logic and the related graphical user interface. There are three main actors: the *controller*, the *collector* and the *supervisor*.

The *controller* represents the hardware mounted in the racks placed along the beam lines (Fig. 1). Each rack can control one or more pumping groups, and is made up of a *multiplexer* (MUX) and a custom box with microprocessor controllers called *PLC*. The MUX controls and acquires information from vacuumeters and pump controllers, and forwards a subset of those data over a RS485 4-wires line. The PLC manages the valves actuation, implements the Machine Protection System (MPS) procedures, and manages high level procedures (i.e vacuum cycle). When the controller manages instruments connected to a cryostat, an additional PLC is present in the rack. This PLC is called Additional (ADD) and manages the valves, connecting the specific cryostat to the vacuum line and used for the He and N₂ inlet procedures. The vacuum line is controlled by a set of special PLCs, called Power Additional, which manage the primary pumps and the main valves connected to that line. All type of PLCs receive and send information over an RS-485 4-wires line, which is not the same of the MUXs.

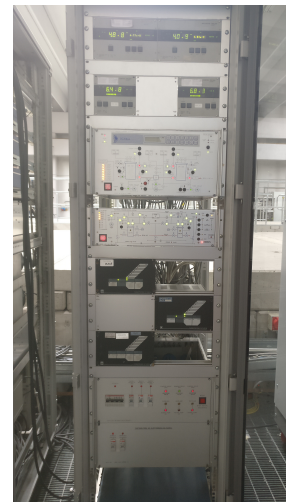

Figure 1: The TELEMA rack mounted in ALPI with MUX, PLC, ADD PLC, vacuumeters and pump controllers.

There are four RS-485 lines connecting (bus mode) the MUXs and four lines connecting the PLCs. Each MUX and PLC has a specific address in its line. There are four Windows PC servers, we will call them *collectors*, which receive the data transmitted over the serial lines and forward them on the ethernet network connected with the console (another Windows PC) in the TANDEM console room. The conversion from serial to ethernet, and polled requests to the racks, are performed by an H8S card, which is currently out of production. This is one of the most relevant problems of this architecture because, in case of damage, we can't replace this item.

The code showing collected data in an organized shape is the *supervisor*. Each server shows the received data in a basic shape, based on the line type, MUX or PLC, and controller address. On the other hand, the console shows received data organized by accelerator line. For each pumping group, it is possible to access to more detailed information, such as the valves status and the vacuum levels; usually a pumping group is mounted below a diagnostic, a cryostat or along the beam line. The graphical user interface changes based on the controller type and the position of the pumping group (Fig. 2).

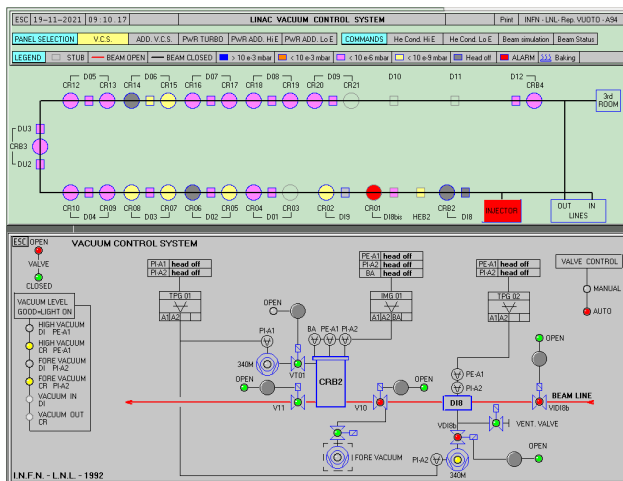

Figure 2: ALPI GUI. VCS page of a specific controller.

EPICS SOFTWARE

In order to perform as few hardware changes as possible, we did not touch the controllers and the serial lines. The first step was to substitute the H8S cards with a MOXA collecting all the RS-485 lines. This way, sending a request to the correct port, each line is reachable from the ethernet network, and we can remove the obsolete hardware.

Verified the communication between MOXA and controllers, we started developing the EPICS IOC. With a frequency of 1Hz, we ask all the controllers to send their current data. Since MUXs and PLCs exchange data with a specific encoding, we developed a custom EPICS *ASYN* port collecting those data. Then a *STREAMDEVICE* specific protocol

parses the received data and removes the header section specifying the message type and the sender address. Since the response time of the controllers is in the order of milliseconds, if the IOC does not receive a response in 10ms from a controller, it raises a timeout error. Once data have been received a C function checks the data length and the message checksum. If the IOC does not receive a response from an address after 10 seconds, the related PV (Process Variables) raises a timeout alarm and the polling frequency with that address decreases to 0.1Hz.

These PVs store the raw data of the payload sent by the controllers. Based on the controller type, knowing the message syntax and knowing the mapping between a controller and the beam line elements, the IOC logic can rearrange those data into meaningful information. Finally, the debugged IOC was deployed on a Virtual Machine (VM) and the old servers were dismissed. A mixed approach (MOXA - Windows servers) was not possible because the legacy software expects to receive the data from the H8S card integrated in the server cage.

GRAPHICAL USER INTERFACE

Now, the EPICS PVs storing VCS data are accessible from the network but a new Graphical User Interface (GUI) able to read them is required. To quickly substitute the current GUI, we developed a new GUI using Control System Studio (CSS) which had the advantage to be easy to use, and well-known at the LNL laboratories. To aid operators in the transition to the new GUI, the pages were developed as similar as possible to the previous GUI. The main difference regards the valves state and pressure levels history tracking pages: since we use EPICS, we can track those values with an archiver and show their trends using the data browser extension provided by CSS. The new GUI was installed on a Kubuntu PC with four monitors and the legacy console was dismissed (Fig. 3).

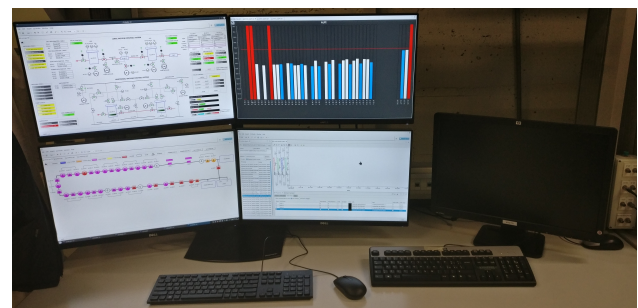

Figure 3: The new Vacuum Control System console.

HARDWARE UPGRADES

As said, the TELEMA vacuum control system racks are custom build by different parts (custom PLCs, *multiplexer*, and more...) properly assembled and configured according to the controlled part (beam line/cryostat). The exchange of process information with the adjacent racks occurs via dry

contacts, while monitoring data are collected by a centralized serial network.

The development of the new vacuum control system rack (Fig. 4), which will replace the legacy once, went in parallel to the software upgrade and was originally designed to control a common straight vacuum line with a maximum of 2 consecutive vacuum sections. In the past years, this design has been reviewed and expanded up to the actual system which is able to control 3 configurations (ALPI Linac, Straight Beam Line, Beam Line Intersections) and up to 4 vacuum sections with the same hardware configuration, avoiding the maintenance of different versions.



Figure 4: The new Vacuum Control Rack.

The new hardware platform is conceptually different from the original one, which foresees the exchange of modular macro parts in case of fault, instead the new design, composed by commercial parts disposed in an accessible way, allows to perform limited interventions with the help of self-diagnostic to simplify the research of faulty elements. The hardware, cabling and part of the software design, were developed by external contractors, but all the know how of this system is internal allowing an easier management.

The core of the system consist of a SIEMENS S7-1500 PLC and a 10" touch panel, for local operations, which are highly available on the market and long time supported by the producer. Moreover the wide spreads SIEMENS platform guarantees a large base of possible supplier for the software parts if needed.

The new control racks are equipped with LAN interfaces to communicate together and with the EPICS supervisor,

or for remote operations. Standard LAN/serial interface converters are used to communicate with controlled devices (vacuum pumps, controllers and more) allowing to support several brand and models and to include new devices in the future. Racks are also equipped with the dry contact interface for compatibility with the previous systems during transition phase.

All configurations, and devices communication, are software managed by the local PLC and HMI, which includes dedicated pages for each device type, for the controller configuration, and a section for the general supervision. During the transition to the EPICS supervisor, some features and operations foreseen for the local operations will be not implemented, but the possibility of remote connection to the touch panel will cover every needed operation.

CONCLUSIONS

The new EPICS IOC and GUI, which substituted the legacy supervisor, is in production since February 2022, and it took 4 FTE (full time equivalent) months to be developed and it is largely appreciated by operators for its fancier behaviour and the new functionalities. We used this opportunity to improve the documentation of the communication logic and syntax, and the system architecture. The tests on read and write operations on valves states and pressure levels allowed us to notice some noise over the RS-485 line. To remove the noise we add a message length and checksum verification; this allowed us to find the damaged PLC and remove it; after the removal we obtained a more stable communication. What remains is to test the logic related to the cycle procedures (centralized procedures involving more controllers at once), when the Power Additional PLCs will be fixed.

The new hardware platform guarantees an easier maintenance and simpler intervention thanks to the industrial standards adopted, giving us the possibility to further extend the features and the supported vacuum devices. The software developments on the new vacuum rack, to support ALPI Linac configuration, are ongoing and the commissioning of the first batch of racks is foreseen by the end of this summer.

REFERENCES

- L. Ziomi *et al.*, "The Vacuum System of the Superconducting Linac of the ALPI project", LNL, Legnaro, Italy, Rep. LNL-INFN(REP)-047/91, 1990.
- C. Roncolato *et al.*, "Status of the Vacuum System for ALPI/PI-AVE section and Upgrading Plan", LNL, Legnaro, Italy, Rep. INFN-LNL-259, 2020.
- G. Savarese *et al.*, "ALPI-PIAVE Vacuum Control System Upgrade: from TELEMA to EPICS", LNL, Legnaro, Italy, Rep. INFN-LNL-266, 2022.
- EPICS, <https://epics-controls.org>