

# PROPOSAL OF A GIRDER REALIGNMENT TEST IN PETRA III

M. Schaumann\*, I. Agapov, R. Bartolini, M. Bieler, R. Böspflug, D. Einfeld,  
M. Hoffmann, J. Keil, L. Liao, G. Priebe, M. Schlösser, R. Wanzenberg  
Deutsches Elektronen-Synchrotron DESY, Notkestr. 85, 22607 Hamburg, Germany

## Abstract

PETRA IV can benefit from the fine control of the girders that carry the storage ring elements to achieve the design beam performance. Based on the corrector magnet strength pattern it is desired to realign girders to stay within the alignment tolerances. In the current PETRA III configuration, the girders in the Max von Laue Hall are equipped for remote alignment, however, those have not been moved since their initial installation and the alignment system is currently not connected to the control system. In preparation for PETRA IV, a movement test of one of the PETRA III girders should confirm the ability to safely and precisely remote control the equipment based on an optics model that describes the effect of the girder movement on the orbit. This paper studies the feasibility of this test and prepares an initial mock-up experiment to be performed on a spare girder.

## INTRODUCTION

The PETRA III storage ring at DESY [1] is currently one of the world's brightest synchrotron light facilities in the hard X-ray range. It is planned to be upgraded to PETRA IV [2,3], which will be operated with an ultra-low emittance providing diffraction-limited hard X-ray beams with more than two orders of magnitude increase in brightness and coherence compared to its precursor. Owing to the lower emittance, PETRA IV will have a factor of two lower alignment and aperture tolerances with respect to PETRA III. Nevertheless, PETRA IV should be build within and extend the existing infrastructure of PETRA III, where the buildings are based on tunnels and halls from different construction periods.

Investigations at PETRA III related to long-term orbit stability and its correlation to environment parameters, including the tunnel temperature and the mechanical movement of different tunnel segments with respect to each other, revealed that without countermeasures the expected ground motion could potentially impact the machine performance of PETRA IV [1,4,5].

Similar to other light sources, the storage ring elements in the lattice of PETRA IV will be placed on girders that mechanically connect and carry a group of elements, such that those can be assembled, transported and aligned as a unit. In order to counteract the misalignment introduced by ground motion and temperature effects, the girders will feature a remote controlled alignment system. Based on the corrector strength patterns and a response matrix, alignment corrections will be applied to individual girders and so provide an alignment stability within the required tolerances [6].

Girder re-alignment based on corrector current data has been successfully performed in other machines [7]. The reconstruction however depends on the actual machine and its properties, like optics, phase advances and arrangement of girders. Therefore, the procedure and model have to be proven individually for each machine.

In PETRA III the Max von Laue Hall (MvL) is equipped with girders that have a remote controllable alignment system (see Fig. 1). However, here the girders are not moved during beam operation, the system has only been used during the initial installation of the elements in the tunnel in 2009. Thanks to the large tolerances, potential movements or drifts are well compensated by the orbit correction system.

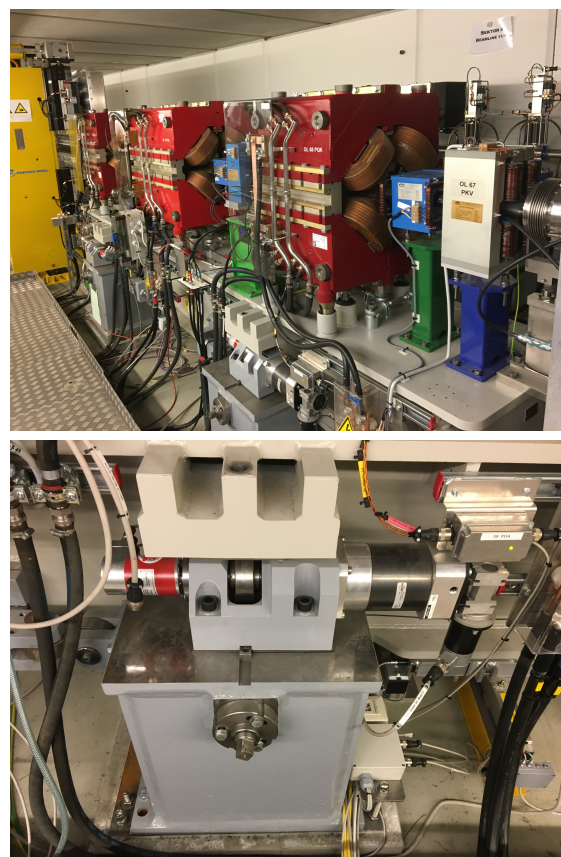

Figure 1: Top: View of a girder installed in the PETRA III tunnel downstream of an undulator (yellow element on the left), carrying three quadrupole magnets. Bottom: Zoom of the motor and encoders installed on the cam-based alignment system connecting the supporting feet to the girder table.

\* michaela.schaumann@desy.de

It is of crucial importance for the PETRA IV performance prospects to understand the limits of the girder-response-matrix model and the accuracy with which this procedure can be performed. Therefore, it was proposed to perform a girder movement test in PETRA III in December 2022 just before the start of the winter shutdown. The knowledge compiled in the preparation and execution of this experiment concerning technical requirements and the automation of the alignment is a valuable input for the design of the PETRA IV system.

This paper evaluates the feasibility and risks of the controlled movement of a single girder in the Max von Laue Hall. Identified challenges and limits are presented, as well as the plans for a proceeding lab test on a spare girder.

## BEAM-BASED GIRDER REALIGNMENT

A girder response matrix, based on the machine optics, can be used to find the relation between girder offset (i.e. collective offset of all elements on a girder) and the required corrector settings to eliminate the effect on the beam orbit. By inverting this matrix, systematic offsets in the operational corrector currents can reveal locations of misaligned girders. However, this requires that the matrix has full rank and is non-singular.

The girder response matrix of PETRA III shows a good ability for localised corrections. However, the limited coverage of correctors and the phase advances within the Double Bend Achromat cells lead to the fact that some girders share certain corrector magnets, which influences the position resolution and the ability to clearly reconstruct the misalignment of individual girders. In general, a girder misalignment is corrected by a combination of the few most efficient correctors nearby. Simulations have shown that the reconstruction of girder offsets works better in the horizontal plane compared to the vertical plane.

The last survey measurements, taken in 2014, show that the misalignment in the MvL Hall is dominated by girder misalignment. Preliminary results of the girder position reconstruction are in agreement with the survey data, but show a more diffused localisation, distributed over a set of adjacent girders.

Even though PETRA III is very different to PETRA IV with respect to the response matrix and sensitivity to misalignment, it is important to prove that the model transforming orbit corrections into girder movements is adequate. Especially the experience with the, for this purpose non-optimised, optics helps to evaluate potential limitations in the design phase and opens the opportunity to foresee countermeasures.

## IDENTIFIED CHALLENGES

Since general girder re-alignment is not foreseen in PETRA III, several technical issues make a complete re-alignment of all installed girders in the MvL Hall difficult. For this reason, the proposed experiment concentrates on re-aligning only a single girder. Nevertheless, even in this

case technical limitations, especially concerning the installed girder motors and vacuum system, have to be taken into account.

## Girder Motors

All girders in the MvL Hall are equipped with cam movers, motors and position encoders for precise positioning of the electron beamline (see Fig. 1). The motors have been used during the initial installation process of the girders in the tunnel before the vacuum equipment was connected.

Currently the motors cannot be moved. The motors and encoders have been sitting unused in the harsh radiation environment of the accelerator tunnel for years. Their individual condition in terms of functionality, ageing and radiation damage have to be examined before they are put back in operation. The system is not connected to the control system. The only possibility to drive the desired position change is connecting an external computer that runs the control software to an individual girder. The optimised position data from 2009 is available to be used as reference and backup point even if the girder's encoder is damaged or lost its position information. As mentioned, the movement procedure has not been performed for many years and needs thus be validated again in a mock-up before moving any tunnel girder (see below).

## Vacuum System

The junctions of the beam pipe and vacuum system between the girders are connected with fixed joints. The bellows (see Fig. 2) that are installed, mostly around the undulators, can cope only with longitudinal movement. As shown in Fig. 3, those bellows feature a stiff connection clamp that allows to freely move longitudinally, but blocks any transverse movement. This design aims to protect the RF fingers to lose contact and prevent movement against the undulator chamber. However, it did not foresee any girder movement or realignment after connection. Moving the girder would not only cause forces to the bellow, but also upstream to the fixed connection towards the undulator chamber and the Beam Position Monitor (BPM), and downstream to the

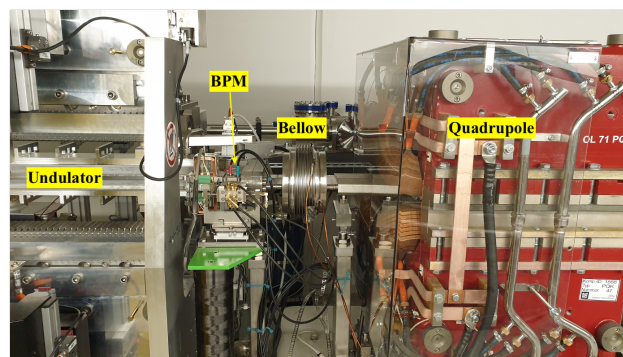

Figure 2: Bellow installed in the tunnel downstream of an undulator (left) followed by a BPM and upstream of a girder (right) carrying a red quadrupole.

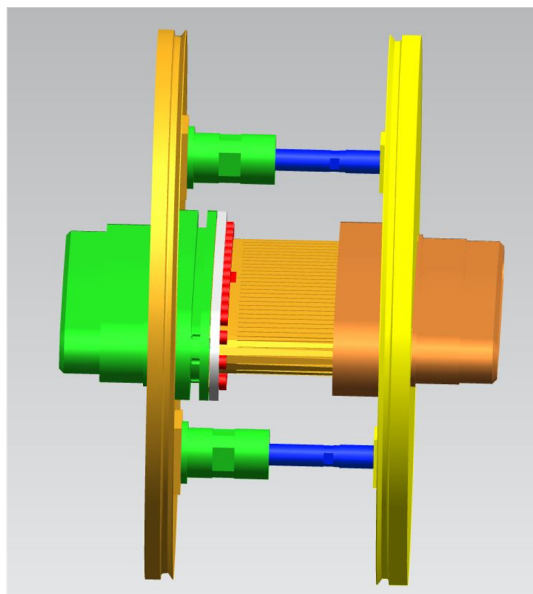

Figure 3: CAD model of the components inside the bellow. The RF fingers are shown in light orange in the middle of the picture, on the top and bottom between the two yellow wheels the stiff connection clamp is shown as blue rods that are placed in the green cylinders.

chamber in the following magnets and BPMs. A movement within the elastic range of the guiding rods seems acceptable in the order of up to  $\pm 300 \mu\text{m}$  [8].

In order to secure the vacuum equipment further and avoid girder movements above the tolerance, the girder alignment system features an additional safety installation that limits the lateral movement between two girders by an electrical connection ('limit switch').

The beam pipe has about one fix point per girder that connects the pipe and the support structure either by a stiff fixed metal plate that avoids movement in any direction or by lying connections that allow longitudinal shifts. Between fix points the beam pipe is hovering closely (down to the order of tens of micrometers spacing) but without touching the elements. A touching of the beam pipe and magnets would lead to a mechanical connection and might cause damage when the magnets move, e.g. by thermal expansion when switching on/off the magnet current. It has to be evaluated by a visual inspection before any girder movement is performed, whether there is enough space within the elements to perform the desired amount of movement without touching.

## PROPOSAL FOR DRY MOVEMENT TEST

The described technical issues make it risky to perform this test immediately in the tunnel. In order to get more familiar with the equipment, develop a safe procedure and detect unknown problems, a dry movement test is planned on the spare girder in a lab environment.

The available spare girder is been used for a transport test, which requires it to be equipped with an aligned set of

magnets and survey monitoring, providing an optimal setup for the here proposed experiment.

The girder itself can be seen as a rigid body that rests on cam movers at both ends. The actual girder movement is performed with motors and encoders that are installed on the cam mover axis of the support feet (see Fig. 1).

A dry test sequence executing the following steps is foreseen:

- Equipping the support feet of the spare girder with motors in the survey lab (which requires lifting off the girder from the support).
- Initial test of the motor equipment and remote-control software on the bare support feet.
- Installation of the spare girder on the support.
- Start, intermediate and end position measurement.
- Remote controlled movement.
- Evaluation of the error between executed and requested movement.

Only if all these preparatory tests are successful the movement of an actual PETRA III girder in the accelerator tunnel would be considered. The dry movement test is foreseen from May 2022. For the dry test, but especially for the tunnel test, it is crucial to continuously monitor the performed movement and vacuum related parameters to guarantee the safety of the accelerator equipment.

## CONCLUSION AND OUTLOOK

The feasibility to remotely move one of the girders in PETRA III storage ring has been evaluated. Several technical challenges have been identified that impose limitations on the movement amplitude and the selection of the girder to adjust. A dry test procedure has been proposed for a proceeding lab experiment, which will give opportunity to train and optimise the execution procedure before applying any movement on the actual accelerator equipment in December 2022.

## ACKNOWLEDGEMENTS

The authors would like to express their gratitude to the technical groups for their advice and help in preparing this experiment.

## REFERENCES

- [1] K. Balewski *et al.*, "PETRA III: A low emittance synchrotron radiation source", DESY-2004-035 (2004). <https://bib-pubdb1.desy.de/record/392205/files/526059656.pdf>
- [2] C. G. Schroer *et al.*, "PETRA IV: Upgrade of PETRA III to the ultimate 3D X-ray microscope", Conceptual Design Report, DESY, PUBDB-2019-03613, <https://bib-pubdb1.desy.de/record/426140>

- [3] R. Bartolini *et al.*, “Status of the PETRA IV project”, in *Proc. 13th Int. Particle Accelerator Conf. (IPAC’22)*, paper TUPOMS029, this conference.
- [4] M. Schaumann *et al.*, “Temperature Effects on the PETRA III Tunnel Stability”, in *Proc. 13th Int. Particle Accelerator Conf. (IPAC’22)*, paper THPOST001, this conference.
- [5] L. Liao *et al.*, “Long-Term Orbit Stability in the PETRA III Storage Ring”, in *Proc. 13th Int. Particle Accelerator Conf. (IPAC’22)*, paper TUPOMS020, this conference.
- [6] T. Hellert *et al.*, “Error Analysis and Commissioning Simulation for the PETRA-IV Storage Ring”, in *Proc. 13th Int. Particle Accelerator Conf. (IPAC’22)*, paper TUPOMS018, this conference.
- [7] S. Zelenika *et al.*, “The SLS storage ring support and alignment systems”, *Nuclear Instruments and Methods in Physics Research A*, vol. 467–468, pp. 99–102, 2001.  
doi:10.1016/S0168-9002(01)00246-7
- [8] R. Böspflug, private communication.