

DEVELOPMENT AND TESTING OF HIGH POWER CW 1497 MHz MAGNETRON*

M. Popovic^{1†}, T. Blassick², M.A. Cummings¹, A. Dudas¹, R. P. Johnson¹, K. Jordan³, R. Lentz¹,
M. Neubauer¹, R. Rimmer³, H. Wang³, J. Wessel², T. Wynn¹

¹Muons, Inc., Batavia, IL 60510 USA

²Richardson Electronics Ltd., LaFox, IL 60147 USA

³Thomas Jefferson National Accelerator Facility, Newport News, VA 23606 USA

Abstract

We have designed, built, and tested a new magnetron tube that generates RF power at 1497 MHz. In the tests so far, the tube has produced CW 9 kW RF power, where the measured power is limited by the test equipment. The final goal is to use it to power superconducting (SC) cavities.

INTRODUCTION

This tube was designed under DOE NP STTR that Mike Neubauer directed as the PI. The design itself was primarily the work of Alan Dudas working with our advisors from California Tube Laboratory (CTL), Tony Wynn and Ron Lentz. The tube, shown in Figure 1, was constructed by companies in California, but final repairs, reassembly, and testing were done at Richardson Electronics (RELL) in Illinois.



Figure 1: Tube at RELL ready to be baked.

DESIGN

This tube is like a 75 kW CW 915 MHz tube designed and built by CTL. The water-cooled tube has 10 strapped cavities. Power is extracted using a three-legged antenna

* Work supported by DOE NP STTR DE-SC0013203 and Muons Inc. and Jefferson Lab CRADA JSA 2016S004

† popovic@muonsinc.com

that is enclosed in a ceramic dome. The cathode stalk has a 2 liter/s ion pump and connectors for high voltage and filament power input. These elements are shown in Figures 2a and 2b.

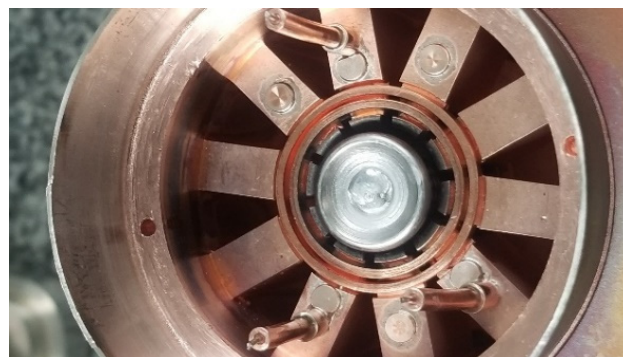

Figure 2a: Picture showing 10 cavities, straps, and antenna posts attached to the vanes of the anode body.



Figure 2b: Antenna attached to anode body.

The design process involved special consideration regarding heat distribution and removal. The biggest concern with heat dissipation was related to the cathode stalk. After assembling the filament, the temperature of the helical filament was measured in a Bell jar for several different currents. The conclusion was that 75 amps and around 8 volts will create conditions for large electron emission.

Content from this work may be used under the terms of the CC BY 4.0 licence (© 2022). Any distribution of this work must maintain attribution to the author(s), title of the work, publisher, and DOI

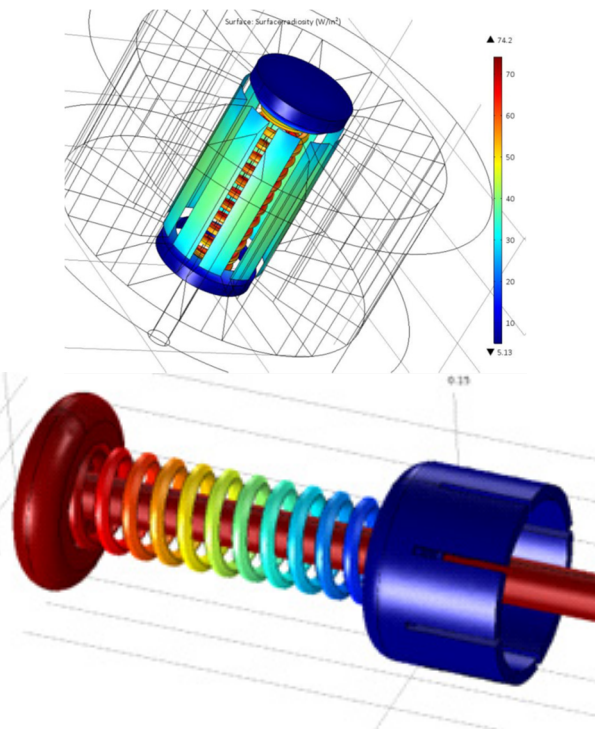

Figure 3: Cathode filament temperature distributions.

RF and Thermal Simulations

To simulate E&M and thermal characteristic of the tube we use COMSOL [1]. The same program was used in the design stage. Figure 3 shows the cathode temperature distribution under 600 W of filament power. Figure 4 shows the E-field of eigen frequency solution for the pi-mode. Figure 5 shows the anode body temperature distribution including cooling water-flow.

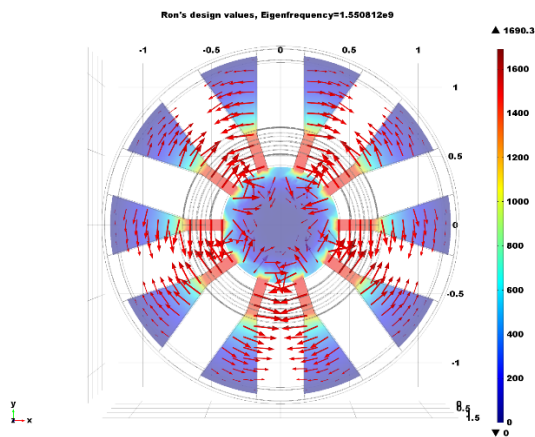

Figure 4: Electric field for pi-mode.

The program has shown its usefulness at initial stage of low power testing when it, together with measurements, indicated a problem with the tube that stopped us from putting high power into a malfunctioning tube.

Low Level RF Test

Initial assembly of the tube was done in summer of 2020 in California. The test discovered a water leak in the anode body and the tube was opened and the leak was repaired!

The tube was then shipped to Illinois in May of 2021 and the first low power test was attempted on 21 Sept of 2021 at RELL. The measurements gave a resonant frequency of 1.64 GHz instead of the design value of 1.495 GHz and the power coupling was too small. The decision was made to open the tube again and a short was found on one of the strapped rings. After repair and before vacuum closing, the frequency was verified using two loop measurements. The frequency was 1.53 GHz, the coupling reasonable and the tube was baked and pinched off.

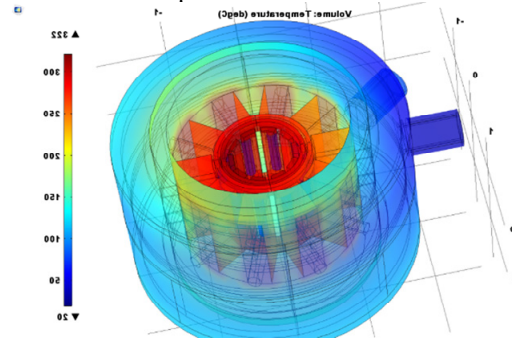

Figure 5: Anode body and water-cooling T distributions.

In low power tests of the tube showed similar characteristics as was seen in simulations. Figure 6 shows the model of the tube and launcher. Figure 7 shows the Smith Chart of the first measurements.

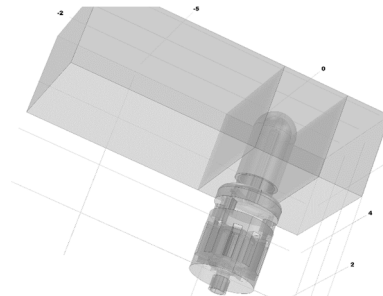

Figure 6: COMSOL Model of Tube and Launcher.

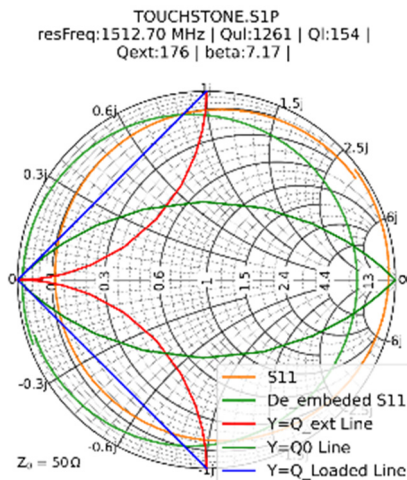

Figure 7: Qs from model and low level 'measurements'.

RF POWER TEST

On December 15, 2021, power was generated for the first time. Due to the lack of cooling on the dome and terminals a decision was made not to run with power more than 3 kW. Next two months were used to modify the launcher and terminal connections. The system has cooling for power up to 30 kW. As of the middle of March of 2022 we have achieved steady operation (Figure 8, 9 and 10), with power up to 8 kW.

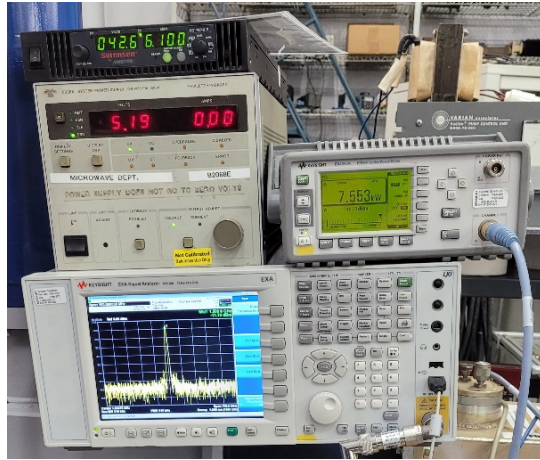

Figure 8: RF signal spectrum and power read while generating CW 7.5 kW for hours.

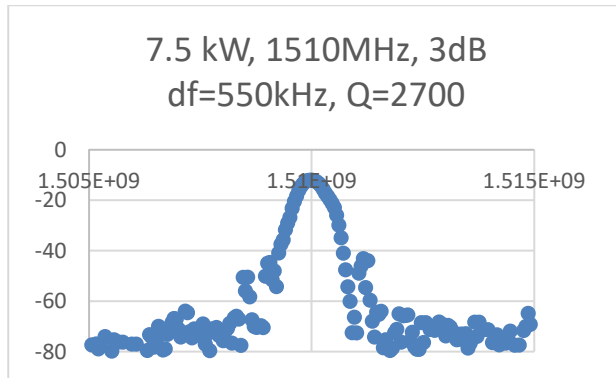

Figure 9: RF signal at 7.5 kW, single trace.

All taken data so far can be reproduced using the Vaughan [2] model, if at ~7.5 kW output power, 10% of input DC power is spent on cathode back bombardment. Input in the model is geometry of the tube dimensions and the Q's of the tube has used the numbers produced in simulations,

If the model is correct, as can be seen from plot, this tube can easily produce 20 kW CW RF with efficiency above 70% with a power supply capable of 4 Amps at anode voltage ~9 kV Amps assuming 4% back bombardment of the cathode. This should be also power level at which the filament input power can be cutoff but the emission maintained by the back bombardment.

As can be seen from the Vaughan model (Figure 11), the dominant loss is from transverse motion term and back bombardment of cathode is not the dominate loss mechanism. Displayed quantities are calculated using (arbitrary)

MC7: Accelerator Technology

T08: RF Power Sources

parameters 1.6 and 0.04 suggested in the Vaughan paper [2]. There was no attempt to adjust these parameters to reproduce exactly measured power and efficiency. Assuming that this model is correct, the internal loss of power is not small, ~ 20% but an improvement of unloaded Q can lead to the increase of tube efficiency.

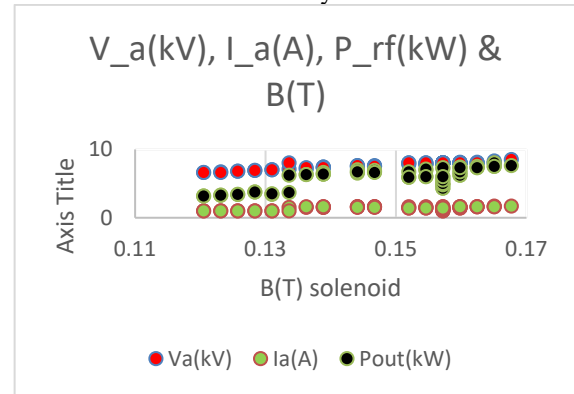

Figure 10: RF power, anode voltage and current vs. magnet field.

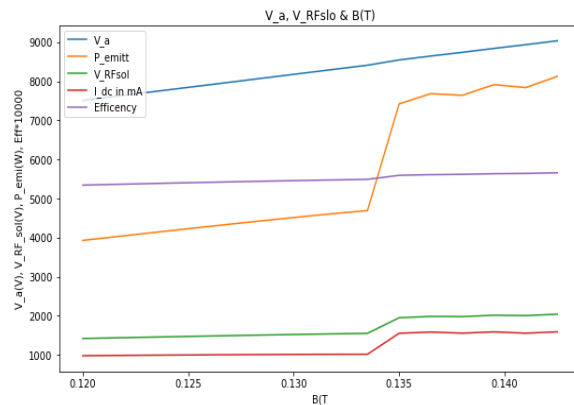

Figure 11: Calculated quantities using Vaughan model.

There is a simple way to understand the results of the measurements. The power supply is a constant current source. So, setting the anode DC current to some value, let say 1.5 Amp, forces the power source to adjust the anode voltage to some value for a particular magnetic field value. If the magnetic field is increased, that means electrons are more squeezed near the cathode, so to be able to pull the requested current, the power supply has to increase the anode voltage.

CONCLUSION

The Muons, Inc. prototype 1497 MHz tube has been commissioned and factory tested. On May 23, 2022, the tube was delivered to Jefferson Lab for further tests and to develop magnetron systems to drive SC RF cavities.

REFERENCES

- [1] COMSOL, <https://www.comsol.com/>
- [2] J. R. M. Vaughan, "A millimetre wave magnetron", *Proc. Inst. Elec. Eng.*, 1955-Aug.

TUP0TK058

1353