

## CW RF SYSTEMS OF THE CORNELL ERL INJECTOR\*

S. Belomestnykh<sup>#</sup>, Z. Conway, J. Dobbins, R. Kaplan, M. Liepe, P. Quigley, J. Reilly, J. Sikora, C. Strohmman, V. Veshcherevich, CLASSE, Cornell University, Ithaca, NY 14853, U.S.A.

### Abstract

Two high power 1300 MHz RF systems have been developed for the Cornell University ERL Injector. The first system, based on a 16 kW CW IOT transmitter, is to provide RF power to a buncher cavity. The second system employs five 120 kW CW klystrons to feed 2-cell superconducting cavities of the injector cryomodule. The sixth, spare klystron is used to power a deflecting cavity in a pulsed mode for beam diagnostics. A digital LLRF control stem was designed and implemented for precise regulation of the cavities' field amplitudes and phases. All components of these systems have been recently installed and commissioned. The first operational experience with the systems is discussed.

### INTRODUCTION

A prototype of the ERL injector [1], under commissioning at Cornell University's Laboratory for Accelerator based Sciences and Education (CLASSE), is the first step toward the future X-ray light source based on the Energy Recovery Linac (ERL) [2]. The injector faces a challenging task of producing high-current, ultra-low-emittance beam. This, in turn, imposes very stringent requirements on its RF systems [3]. There are three different types of cavities, all operating at 1300 MHz: buncher cavity [4], five 2-cell superconducting (SC) cavities [5], and deflecting cavity [6]. Due to different power requirements for buncher and SC cavities, two different RF systems have been developed. The buncher RF is based on a 16 kW CW IOT transmitter. The injector cryomodule (ICM) RF system employs five 120 kW CW klystrons. The sixth, spare klystron is used to power a deflecting cavity in a pulsed mode for beam diagnostics. A new generation of the Cornell low level RF (LLRF) controls is used for precise cavity field regulation. All components of the RF systems have been recently installed and commissioned.

### RF FOR BUNCHER CAVITY

Specifications of the buncher RF system are listed in Table 1. As power requirements for this system are quite moderate, an IOT-based high power amplifier (HPA) was chosen. The HPA was manufactured by Thomson-BM. The system includes a 16 kW CW tube TH 713 (manufactured by Thales-ED) incorporated into a modified version of the DCX SIIA broadcast transmitter system. The high voltage power supply is manufactured by NWL. The block diagram of this system is shown in Figure 1. The HPA was tested at the factory and then at Cornell upon delivery [7].

A very small vacuum leaks were found in the buncher cavity tuners after the cavity installation. Vacuum dams were implemented to allow the injector operation while replacement tuners are being manufactured. After that the buncher was powered and commissioned up to 160 kV. A rather strong multipacting (MP) was observed during cavity processing. The multipactor exists at cavity voltages above 49 kV with the highest out-gassing between 60 and 70 kV. While the cavity body and input coupler are not susceptible to multipacting, it was found that the electric field in a small gap between the tuner plunger and the port is high enough to bring this area into the first order MP zone. It requires many hours to process this multipactor.

Table 1: Buncher RF Specifications

Number of cavities	1
Nominal accelerating voltage	120 kV
Maximum accelerating voltage	200 kV
Shunt impedance, $R = V^2/2P$	2.1 MOhm
Maximum dissipating power	9.6 kW
Maximum transmitter output power	16 kW
Amplitude stability	$8 \times 10^{-3}$ (rms)
Phase stability	0.1° (rms)

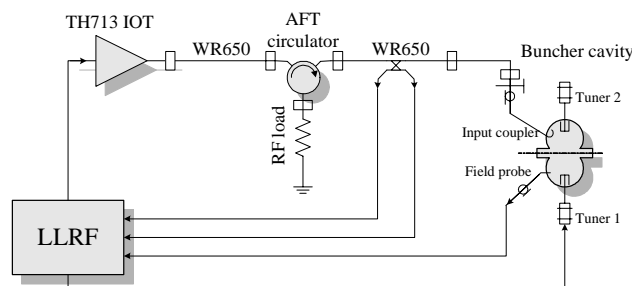

Figure 1: Block diagram of the buncher cavity RF system.

### INJECTOR CRYOMODULE RF SYSTEM

ICM houses five two-cell SC cavities, each delivering up to 100 kW of RF power to beam. As each cavity operates independently, the system consists of five identical channels. RF power is delivered to cavities via twin input couplers [8], each carrying up to 50 kW CW. Main parameters of this system are given in Table 2 and its block diagram is presented in Figure 2.

\* Work is supported by the NSF grant PHY 0131508.

<sup>#</sup>s.belomestnykh@cornell.edu

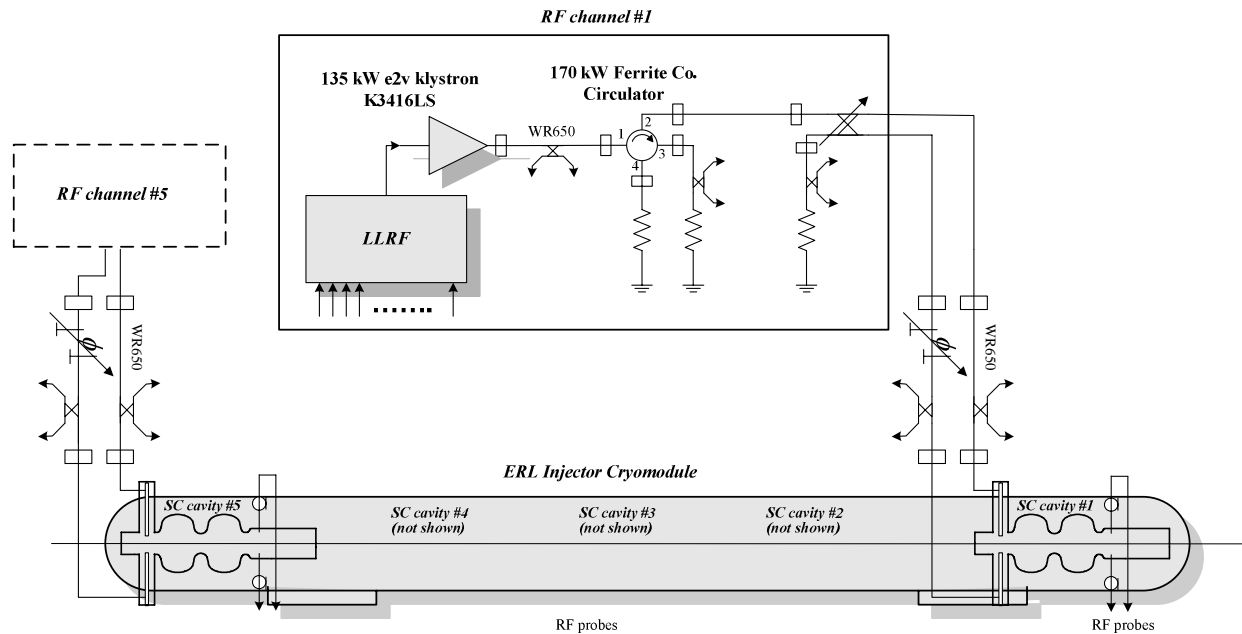

Figure 2: Block diagram of the ERL injector cryomodule RF system.

Table 2: Specifications of the ICM RF system

Number of cavities	5
Accelerating voltage per cavity	1 – 3 MV
2-cell cavity length	0.218 m
$R/Q$ (linac definition)	222 Ohm
$Q_{ext}$	$4.6 \times 10^4 - 4.1 \times 10^5$
RF power per cavity	100 kW
Maximum useful klystron power	$\geq 120$ kW
Amplitude stability	$9.5 \times 10^{-4}$ (rms)
Phase stability	$0.1^\circ$ (rms)

The twin-coupler cavity design requires an adjustable short-slot hybrid power splitter and a motorized two-stub phase shifter in one of the waveguide arms after the split [9]. Four input couplers were tested at high power in a specially designed liquid-nitrogen-cooled cryostat [10]. Maximum RF power level during the test of production input couplers was 61 kW. The test showed that couplers meet requirements of the ERL Injector.

The cryomodule RF system utilizes six klystrons K3415LS manufactured by e2v. The 7-cavity tube has saturated output power of about 160 kW CW. To provide very stable regulation of the cavity field, the klystron must have a non-zero gain and therefore cannot operate in saturation. The maximum useful output power for this tube was defined as a power with an incremental gain of 0.5 dB/dB of drive and specified to be no less than 120 kW CW. At this power level the efficiency should be at least 50% and the tube bandwidth not less than  $\pm 2$  MHz at -1 dB level and not less than  $\pm 3$  MHz at -3 dB level. All

klystrons passed the factory acceptance test meeting the specs at 135 kW before shipping. The tubes were installed and tested again at Cornell.

So far all ICM operations have been at 1.8 K. The cavities have been processed in pulsed mode (2 ms long pulses, 20 ms period) to  $> 15$  MV/m, and in all cases but one the limit was due to vacuum activity in the input couplers. Further processing of input couplers should improve the maximum cavity field. Cavity 4 quenched in pulsed mode at 18 MV/m. In CW mode all cavities reached accelerating voltages of at least 2.8 MV when powered individually (see Table 3). Operation of cavity 1 was limited by excessive RF losses due to field emission (FE). While cavity 2 was limited by the input coupler vacuum, it also had rather significant FE. Operating at 1.8 K with two pump skids, the cryogenic system can handle all five cavities at gradients up to 10.4 MV/m (2.4 MV per cavity). Raising temperature to 2 K will allow for increase of the cryogenic system heat handling capacity and hence higher gradient ICM operation. This operation will be tested soon.

Table 3: ICM Cavity Performance Summary (IC = input coupler vacuum)

Cavity	CW	Limit	Pulsed	Limit
1	2.80 MV	Cryogenics	4.35 MV	IC
2	2.90 MV	IC	3.75 MV	IC
3	3.50 MV	Cryogenics	3.66 MV	IC.
4	3.40 MV	Cryogenics	4.15 MV	Quench
5	3.50 MV	none	5.20 MV	IC
All 5	2.40 MV	Cryogenics	—	—

## RF FOR DEFLECTING CAVITY

A 1300 MHz deflecting cavity [6] is designed to be used for ERL injector beam diagnostics in conjunction with other instruments to measure low-emittance beam parameters. As all those measurements involve beam interception, the average beam current will have to be kept low and hence the beam will be pulsed to keep the bunch charge high. The RF pulse length will be approximately 60  $\mu$ s with the repetition rate up to 1 kHz. Specifications of RF system for this cavity are given in Table 4.

The block diagram of this RF system is presented in Figure 3. The RF system is identical to one of the ICM RF channels with the exception of RF power split and slightly modified FPGA and DSP codes of the LLRF control boards. The system is under commissioning at present.

Table 4: Specifications of the deflecting cavity RF system

Number of cavities	1
Maximum transverse kick voltage	200 kV
Shunt impedance, $Z_t = V^2/2P$	5.3 MOhm
Maximum average dissipating power	200 W
Pulsed RF power	3.8 kW
RF pulse length	60 $\mu$ s
Maximum repetition rate	1 kHz

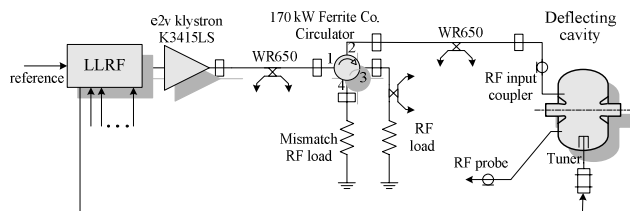

Figure 3: Block diagram of the deflecting cavity RF system.

## LOW LEVEL RF

The LLRF electronics for ERL injector is a new, improved generation of LLRF previously developed for CESR [11]. The new electronics, like the old one, uses VME form-factor. The ERL RF synthesizer is the master oscillator for the ERL injector. A low-noise ovenized oscillator provides the primary 10 MHz reference, which is used to stabilize a 200 MHz VCXO. 50 MHz and 12.5 MHz signals are then generated via appropriate dividers. These signals are used as sampling and clock signals by LLRF digital control boards. The 12.5 MHz signals are also sent to two high frequency PLL circuits, which generate the 1300 MHz RF and 1287.5 MHz LO signals. An Agilent E5052A Signal Source Analyzer was used to measure the phase noise and jitter. The 1300 MHz

signal rms jitter integrated from 10 Hz to 100 kHz is 288 fs. The LO signal rms jitter is 294 fs.

During the first test of the new LLRF with one of the SC cavities the amplitude stability of  $10^{-4}$  rms and the phase stability of  $0.05^\circ$  rms were achieved, exceeding the ERL injector requirements. More details about the LLRF system can be found in [10].

## SUMMARY

The 1300 MHz RF systems for the Cornell ERL injector have been installed and commissioned. ERL injector has begun operation with beam.

## REFERENCES

- [1] I. Bazarov and C. Sinclair, "High Brightness, High Current Injector Design for the Cornell ERL Prototype," *Proc. of PAC'03*, pp. 2062-2064.
- [2] G.H. Hoffstaetter, et al., "Progress toward an ERL Extension of CESR," *Proc. of PAC'07*, pp.107-109.
- [3] M. Liepe and S. Belomestnykh, "RF Parameters and Field Stability Requirements for the Cornell ERL Prototype," *Proc. of PAC'03*, pp. 1329-1331.
- [4] V. Veshcherevich and S. Belomestnykh, "Buncher Cavity for ERL," *Proc. of PAC'03*, pp. 1198-1200.
- [5] V. Shemelin, et al., "Dipole-mode-free and kick-free 2-cell Cavity for SC ERL Injector," *Proc. of PAC'03*, pp. 2059-2061.
- [6] R. L. Geng, et al., "Fabrication and Performance of Superconducting RF Cavities for the Cornell ERL Injector," *Proc. of PAC'07*, pp. 2340-2342.
- [7] S. Belomestnykh, et al., "Deflecting Cavity for Beam Diagnostics in ERL Injector," *Proc. of PAC'07*, pp. 2331-2333.
- [8] S. Belomestnykh, et al., "High Power Testing RF System Components for the Cornell ERL Injector," *Proc. of EPAC'06*, pp. 472-474.
- [9] V. Veshcherevich, et al., "Design of High Power Input Coupler for Cornell ERL Injector Cavities," *Proc. of SRF'2005 Workshop*.
- [10] S. Belomestnykh, et al., "Development of High RF Power Delivery System for 1300 MHz Superconducting Cavities of Cornell ERL Injector," *Proc. of LINAC'2004*, pp. 694-696.
- [11] V. Veshcherevich, et al., "High Power Tests of Input Couplers for Cornell ERL Injector," *Proc. of SRF'2007 Workshop*.
- [12] M. Liepe, et al., "A New Digital Control System for CESR-c and the Cornell ERL," *Proc. of PAC'03*, pp. 3347-3349.
- [13] M. Liepe, et al., "Experience with the New DIGITAL RF Control System at the CESR Storage Ring," *Proc. of PAC'05*, pp. 2592-2594.
- [14] S. Belomestnykh, et al., "Commissioning of the Cornell ERL Injector RF Systems," *Proc. of EPAC'08*, pp. 832-834.