

# A NEW MEDIUM ENERGY BEAM TRANSPORT LINE FOR THE PROTON INJECTOR OF AGS-RHIC\*

M. Okamura<sup>#</sup>, B. Briscoe, J.Fite, V. LoDestro, D. Raparia, J. Ritter  
BNL, Upton, NY 11973, U.S.A.

N. Hayashizaki, RLNR, TITech, Tokyo 152-8550, Japan

## Abstract

In Brookhaven National Laboratory (BNL), a 750 keV medium energy beam transport line between the 201 MHz 750 keV proton RFQ and the 200 MeV Alvarez DTL is being modified to get a better transmission of the beam. Within a tight space, high field gradient quadrupoles (65 Tm) and newly designed steering magnets (6.5 mm in length) will be installed considering the cross-talk effects. Also a new half wave length 200 MHz buncher is being prepared. The beam commissioning will be done in this year.

## INTRODUCTION

It is commonly preferred to have a short distance between an RFQ and a consequent DTL, however many devices has to be accommodated within a limited space. Our new medium energy beam transport line for proton beam is categorized as one of the severest cases. We only have 700 mm in length between the RFQ and the DTL.

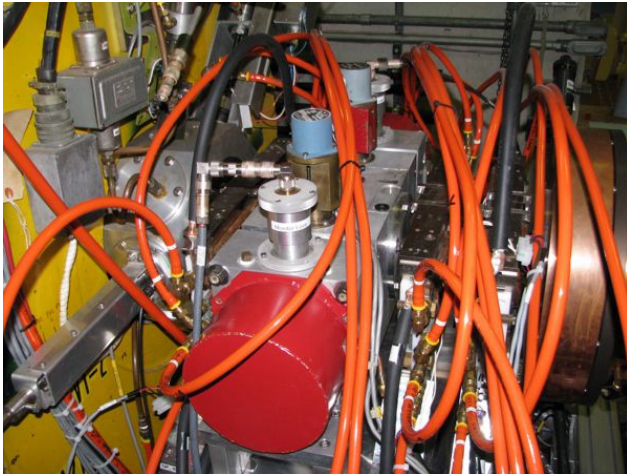

Figure 1: Photo of the current MEBT.

The Alvarez DTL operated at 6.67 Hz of rep. rate provides 200 MeV polarized H<sup>-</sup> beam for the spin program at Relativistic Heavy Ion Collider (RHIC) and also provides 116 MeV high intensity un-polarized proton beam for Brookhaven Linac Isotope Production (BLIP) [1]. The RHIC program needs 2 pulses every AGS cycle (~4 sec), one for injection into the Booster and other for polarization measurement in the 200 MeV polarimeter located in the high energy beam transport line (HEBT). The rest of the pulses go to the BLIP. The requirements for these programs are quite different. The RHIC spin program needs 200  $\mu$ A beam current with 400  $\mu$ s pulse

length. The polarization is required as high as possible with minimum beam emittance. The BLIP needs 450  $\mu$ s pulse length with the highest available current (~40 mA) and uniform beam distribution at the target. The linac chain needs to satisfy both requirement and the emittance growth has to be minimized.

The MEBT was modified and shortened in 2008 from 7 m to only 700 mm since we eliminated an old merging beam line from an atomic polarized source which was already abandoned about ten years ago. However, the quadrupoles and a buncher cavity are “second hands” products and there was no space to install some steering magnet. Now we plan to install newly designed dedicated quadrupole magnets, steering magnets and a half wave length buncher.

## QUADRUPOLE MAGNETS

The MEBT has three electric quadrupole magnets and single permanent quadrupole magnet which is attached to the tank wall of the RFQ. The only the electric magnets will be replaced. The basic design of the quads is almost identical to the one used in the RHIC EBIS project [2] those are already working properly. Since particle's rigidity is lower than that in EBIS's requirement, the magnets yoke thickness was reduced from 70 mm to 45 mm. The volume of the magnetic return paths were reinforced (transverse direction) to avoid the effect from the thinner yoke profile. The designed magnet parameters are listed in Table 1. The yoke is laminated and the magnets will be pulsed. The coils has two layers. Hollow conductors are used at only inner layer of the coils due to limited winding spaces. The hollow conductor layer has 12 turn with 5 x 5 mm with 3mm of I.D. for water passage and the solid outside coil layer has 18 turns with 1.5 x 4 mm.

Table 1: Design Parameters of the Quadrupole Magnets

Bore diameter	32.5 mm
Yoke thickness	45 mm
Height/Width	219 mm
Current	280 A
Number of turns	28 turns/pole
Inductance	2.8 mH
Field gradient at magnet center	64.9 T/m
Effective length	6.0 cm
Integrated 12 poles (r = 10 mm)	2.5E-5 / $\int$ 4poles
Integrated 20 poles (r = 10 mm)	1.3E-3 / $\int$ 4poles

\*Work supported by US. DOE.

<sup>#</sup>okamura@bnl.gov

### STEERING MAGNETS

It was challenge to put conventional steering magnets in the dense MEBT area. So we are proposing plate type steering magnets instead. The idea of the steering magnet was already shown in the previous paper [3]. Figure 2 shows a photo of the one of fabricated magnets. The thickness of the magnet is only 6.35 mm at the pole tip. The gap size is 51.3 mm. The pole shape was controlled to minimize integrated sextupole component along the beam axis which is well below 5E-5 respect to the main dipole component at a 15 mm of reference radius. The return yoke thickness around the coil region was increased up to 12.7 mm to have uniform field flux distributions in the yoke. At 4800 A turn, the maximum field in the iron was controlled to reach 1.5 T which is just below the saturation range of the material. The maximum dipole field reaches 415 Gauss (4200 Gauss cm) with no-cross talk condition.



Figure 2: Steering magnet.

### CROSS TALK EFFECT OF THE MAGNETS

The plate type steering magnets can be installed into a tiny adjacent in a beam line. However we need to investigate the reduction effects from neighboring magnetic materials. In our case, the main effects are given by the quadrupole yokes and some are from the DTL's tank wall. Figure 3 shows an example of the most severe case of the cross talk between a quad and a steering. The distance, from the center of the quad and the center of the steering is 45 mm, corresponding only 19.4 mm between each yoke surface. The simulated dipole components along the beam axis are shown in Fig. 4. The yellow curve shows the no-cross talk steering field. The green curve shows the field under the effect of non-current quad yoke. In the quad section, the dipole field is shielded. The blue curve shows both the steering and the quad are energized case. Due to saturation of the quad yoke, the dipole field partially penetrates in the quad region. The steering dipole field could be reduced and the reduction effect was varied due to the excitation condition of the

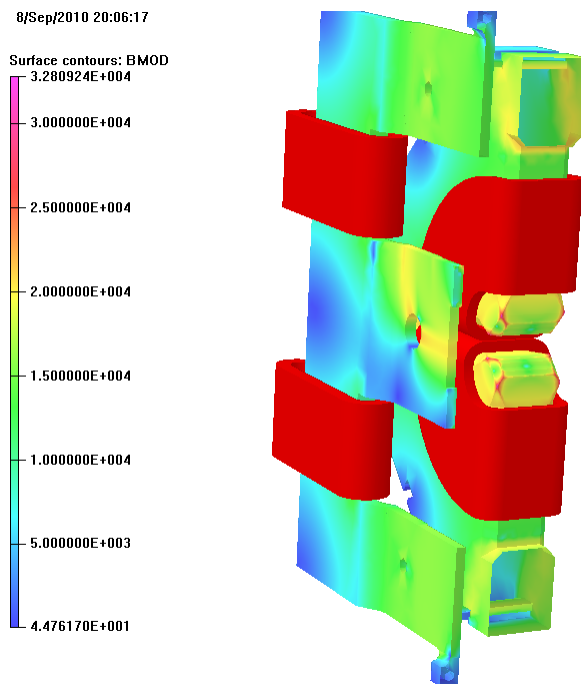

Figure 3: Cut view of the 3D model with a quad and steering magnets.

quad, however one can say that the plate steering works within a reasonable range. The simulation also indicated almost no effect to the quadrupole field due to the presence of the steering yoke.

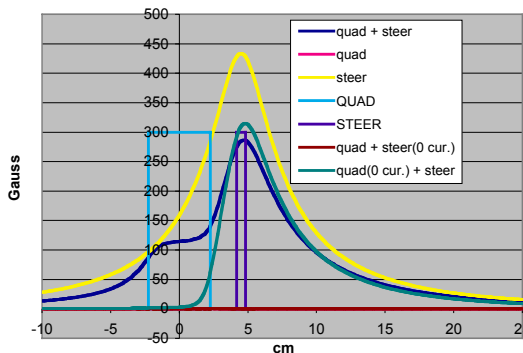

Figure 4: Cross talk of steering field.

### BUNCHER

The existing buncher has very unique structure. The basic resonating structure is a typical half wave length double gaps. However the both end of the cavity are separated from the center gap region by plastic windows. The only center part is in vacuum. This unique structure makes complicated mechanical structure and relatively low Q value, only a few hundred. Then a completely new buncher is being prepared. The new buncher has the same resonant structure but is machined from a single aluminum block. No connection exists along the current path. The field accuracy is fully depends on the machining accuracy. The drift tube's alignment is not needed.

### Model Test

In July 2010, a cold prototype buncher was built and offered by TIME Co., Hiroshima, Japan. All the measured values at the low power test were as predicted. The Q value was 4180 at 200.71 MHz and a frequency shift due to vacuum was 60 kHz up. Since it was vacuum tight, we decided to put a high power to the cold model. A frequency tuner was made and one of the pick up loop was modified to obtain 50  $\Omega$  matching as a power feed. At the beginning of the high power test, we observed multipactoring around 1 kW of input power, but it was finally eliminated after several days of conditioning and went up to 5 kW. Probably, a high value of secondary electron emission coefficient of oxidized aluminum surface could trigger the discharges in our case.

### New Buncher Cavity

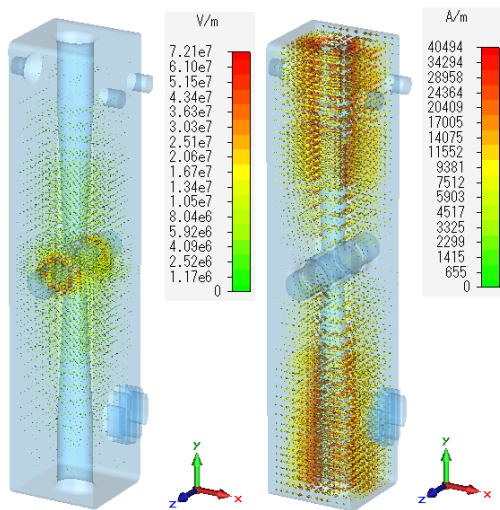

Figure 5: RF simulation. Left: electric field, Right: magnetic field.

Table 2: Design Parameters of Half Wave Length Buncher

Resonant frequency	201.25 MHz
Quality value	> 4000
Beam bore size ; I.D.	32 mm
Beam energy (proton)	750 keV
Max. RF power	3 kW
Shunt impedance	1.5 M $\Omega$

The design (Fig. 5 and Table 2) was slightly modified from the prototype. The inner stem which hold the drift tube was a simple cylinder in the prototype but is changed to oval cross section and is slightly tapered. We expect this will help to reduce the resonant electric discharge condition. Also the inner surface is treated by Alocrom 1000 which suppress the secondary electron emission efficiency. The new buncher was fabricated [4] in September 2010. The loaded Q value was measured as 2120 at 201.25 MHz. The photo of the buncher is shown in Fig. 6.

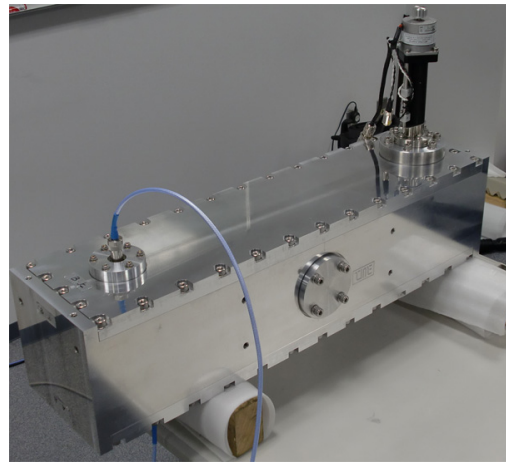

Figure 6: New buncher.

### SUMMARY

To enhance the performance of the proton linacs, the MEBT is being modified. New quadrupole magnets, steering magnets and a half wave length buncher as shown in Fig. 7 will be installed and be commissioned soon.

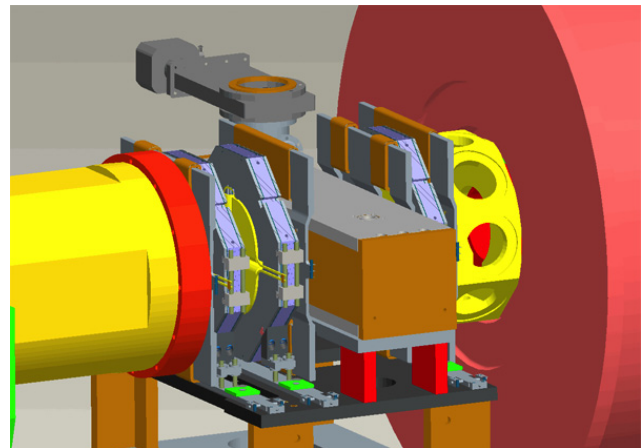

Figure 7: New MEBT.

### REFERENCES

- [1] D. Raparia et al., "Results of LEBT/MEBT reconfiguration at BNL 200 MeV linac", Proc. of PAC09, Vancouver, BC, Canada, MO6RF027.
- [2] M. Okamura et al., "Beam commissioning results for the RFQ and MEBT of the EBIS based preinjector for RHIC", these proceedings, TUP034.
- [3] M. Okamura et al., "Steering magnet design for a limited space", Proc. of PAC09, Vancouver, BC, Canada, MO6PFP005.
- [4] <http://www.time-merit.co.jp/>.