

## UPGRADE OF THE RF PHOTO-INJECTOR FOR THE DUKE STORAGE RING\*

V.G. Popov, J. Li, S.F. Mikhailov, P. Wallace, P. Wang, Y. K. Wu  
FEL Laboratory, TUNL and Duke University, Durham, NC, USA

### Abstract

The Duke FEL and HI $\gamma$ S (High Intensity Gamma-ray Source) facility consists of a linac preinjector, a booster injector, and a main storage ring. The booster injector and storage ring are operated with a wide range of beam energies (240 MeV - 1.2 GeV). The electron beam source located at the beginning of the linac is a 2.856 GHz microwave photo-injector with a LaB<sub>6</sub> cathode which produces 1 ns long pulses with a typically 0.1 nC of charge per pulse. The operation of a photo-cathode gun is important for minimizing the radiation background and reducing the amount of radiation shielding necessary for the full-energy, top-off booster injector. A reliable, effective and clean injection of the booster injector has been realized since 2006. Recently, substantial improvements have been made to the photo-cathode and linac, including the improvement of the nitrogen drive laser, development of a driver laser optical transport and beam monitoring system, and optimization of the cathode heater setting to minimize the thermionic emission. A beam charge measurement system based upon Faraday cup detectors and sample-and-hold electronics has also been developed. In this paper, we present the impact of these upgrades on everyday operation and discuss possible further modifications of the Duke linac pre-injector.

### INTRODUCTION

The accelerator facility for the Duke FEL and High Intensity Gamma-ray Source (HIGS) consists of a linac pre-injector, a top-off booster injector, and the storage ring. The S-band RF gun with the LaB<sub>6</sub> cathode was initially operated in the thermionic mode, producing a long electron beam pulse and a large radiation background. In 1997, the thermionic RF gun was converted to a photo-cathode operation using a nitrogen drive laser for single bunch injection into the storage ring. The photo-cathode operation typically delivers 0.1 nC of charge in a 1 ns long pulse to the linac. The photo-cathode operation was an important consideration for the radiation shielding design of a full-energy, top-off booster injector.

### LINAC PREINJECTOR

Originally designed to deliver an electron beam with energy up to 270 MeV, the linac consists of eleven standard SLAC sections and an RF gun. Until 2008 the accelerator was powered by three S-band klystrons. The linac sections are grouped into clusters, with each cluster fed by a single klystron. The first cluster consists of the

gun and three sections with the remaining two clusters consisting of four sections each. The RF gun with the LaB<sub>6</sub> cathode was initially operated in the thermionic mode; it was capable of producing several nC of charge in 50 to 100 ns long pulses with substantial radiation background. In 1997 [1], a 377 nm, transversely excited atmospheric (TEA) nitrogen laser was installed to convert a standard microwave electron gun to a photo-cathode electron gun.

In 2006 a booster-injector synchrotron was commissioned as the full-energy injector to the storage ring. Since then, the linac has seen a number of modifications. The most significant improvement was the lowering of the linac energy from 270 MeV to 180 MeV [2], [3]. This change allowed us to set aside one modulator-klystron system as a standby spare. It also increased the reliability of the linac and considerably simplified the tuning of the linac.

### Drive laser

One of the critical components of the reliable operation of the linac is a drive laser. We have two identical nitrogen lasers: one in operation and another one as a spare. The main parameters of the lasers are:

- type - MSG 801 TD
- manufacturer - LTB Lasertechnik Berlin GmbH
- wavelength – 337 nm
- energy – 400  $\mu$ J/pulse
- pulse width - 0.5ns
- max repetition rate - 10Hz
- pulse width – 0.5 ns
- pulse stability -  $\pm$ 3%
- jitter with external trigger -  $\pm$ 2.5 ns (typical)
- year of manufacturing - 1996 and 1999

The high voltage electrodes of a nitrogen laser require periodical maintenance. The maintenance schedule for the electrodes is set for every 3 millions of shots, which translates to about 10 months of operation time with a two-shift, five-day operation schedule. Some minor modifications in the control electronics of the lasers based upon our experience have improved overall reliability and simplified maintenance.

An effective delivery of the laser light to the photo-cathode is also very important. A remotely controlled optical beam system was designed and developed. This system allows an operator to adjust the position of the laser spot on the photo-cathode from the accelerator control room.

\*Work supported by U.S. Department of Energy grant DE-FG02-01ER41175.

†vpopov@fel.duke.edu

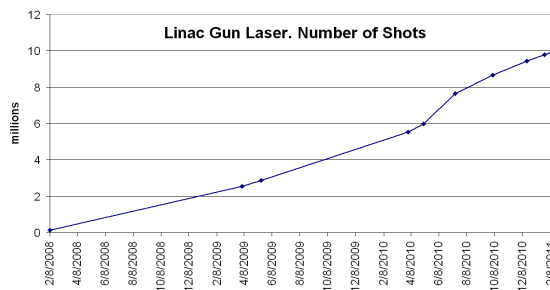

Fig. 1. Accumulation of the number of pulses generated by the nitrogen laser over last three years.

### Charge Measurement System

One key component for effective linac tuning is beam charge diagnostics. The linac pre-injector has a number of instruments for a beam charge measurements. Originally, the linac employed three pulse transformers, a wall current monitor and two Faraday cups. The short length of the pulse from the wall current monitor requires fast and expensive electronics to be integrated in the EPICS system. Moreover, the magnitude of the pulse depended on the transverse beam position. During the HIGS upgrade, in order to measure charge along the linac we developed two sets of electronic systems for Faraday cups. These do not look like traditional Faraday cups. Each Faraday cup is a mass of aluminum mounted on the isolated platform. The electrical potential of this “cup” is proportional to the beam charge absorbed by aluminum. We designed and developed a simple electronic device based on the sample-and-hold technique which was triggered by the front edge of the voltage pulse. The hold time at tens of milliseconds is long enough for measurements using a conventional ADC

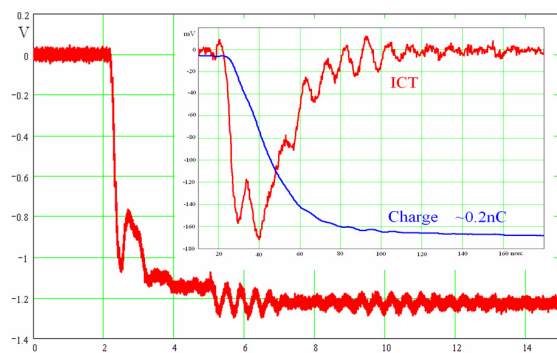

Figure 2. The charge measurement using HES Faraday cup and ICT. Digitally integrated ICT signal in the inset is used to calibrate the Faraday cup.

The two linac Faraday cups are combined with energy spectrometers. The low energy spectrometer (LES) is located at the exit of the first section of the linac where the electron beam energy is about 30 MeV. The high energy spectrometer is installed at the end of the linac. Both LES and HES Faraday cups have been calibrated using a Bergoz Integrating Current Transformer (model “ICT-082-070-10:1”). The accuracy of charge measurement using Faraday cups is limited by the noise

level; for an electron beam pulse of 0.1 nC, the measurement accuracy is about 5%.

In the present configuration one ICT installed on the linac-to-booster (LTB) beam transport line monitors the efficiency of beam injection. This ICT is factory-calibrated to have an absolute accuracy better than 0.5%. However, in practice, the measurement accuracy is limited by the low beam signal in a noisy environment; for a typical charge per pulse of about 0.2 nC, the ICT voltage is less than 15 mV on a 50 Ohm load. A broadband amplifier with a gain of 10 based on the OPA567 operational amplifier has been designed and developed to improve the signal-noise ratio. With this amplifier we are able to reliably measure the beam charge using the ICT with a reasonable accuracy.

### Increased Charge from the Linac

Currently, the intensity of gamma ray the HIGS at gamma energies above 20-25 MeV is limited by the injection rate into the storage ring as Compton scattered electrons are lost after transferring a large amount of energy to photons. In 2009 the booster was upgraded from a single bunch injection scheme to a multi-bunch operation mode. Now the linac delivers seven bunches to the booster every booster cycle with a repetition rate of 4 Hz. The booster cycle lasts 3.3 – 5.5 sec, and about 300 pC of charge is delivered to the storage ring. A higher linac injection rate of 5 to 10 Hz can be achieved by upgrading the high voltage power supplies of the RF modulators

The operation of the photo-cathode at a higher repetition rate results in fast contamination of the cathode surface, which results a more rapid decay of electron emission rate. Operating the cathode at an elevated temperature provides continuous conditioning of the cathode, therefore mitigating the surface contamination problem. A down side of this solution is a much higher level of radiation background in the linac tunnel and in the booster vault due to enhanced thermionic electron emission. Therefore reliable and non-destructive monitoring systems for charge along the linac are of critical importance for higher charge operation.

### Linac Charge Monitor

As mentioned above, there are three pulse current transformers located along the linac. The main parameters of the transformers are:

- Type - Strangenes CT 3-1.0:
- Output -1 V/A
- Rise time – 20 ns
- Droop - 0.2 %/usec
- I\*T max – 2 mA\*sec

Assuming a 0.3 nC charge per pulse with a 1.5 usec pulse duration, a rough estimate predicts a transformer output voltage as low as 0.2 mV. A broadband pre-amplifier and a simple analog integrator has been designed and developed to convert a 1.5  $\mu$ sec long pulse into a slow decaying signal with a time constant of about 50  $\mu$ sec and a voltage of few hundreds of mV. Because

the length of the pulse (~1.5  $\mu$ sec) is a few orders of magnitude shorter than the time separating the electron macropulses (e.g. 100 msec at 10 Hz), it is possible to

achieve a reasonable accuracy of the integration without the need to use switches to reset the integrator and to subtract the voltage offset.

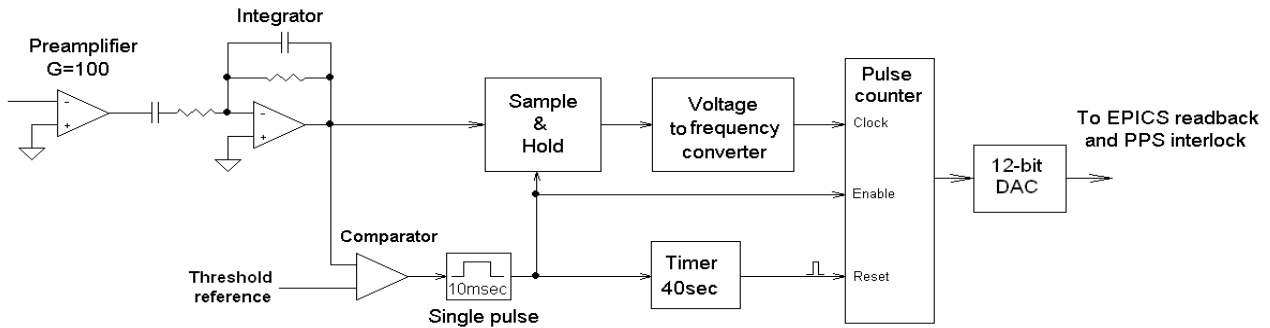

Figure 3. Block diagram of the linac charge monitor

A “sample and hold” circuit is triggered by the front edge of the pulse, and captures the peak value of the pulse, which is proportional to a charge. This signal is held for about 10 msec for further signal processing. Optionally, for the better accuracy, a “sample and hold” device can be triggered from the linac timing system. For radiation protection purposes, we are interested in measurements of the charge averaged over a certain period of time, say one minute. Such a long term integration is better to carry out using a digital technique. The voltage, proportional to the single pulse charge and stored in the “sample and hold” unit, is converted to a frequency. A multistage pulse counter performs digital integration, with practically an unlimited dynamic range. The digital output of the counter can be used directly or be converted to an

analog signal. In our case, an analog signal is a preferred output.

A fully functional charge monitor prototype has been developed and tested successfully. We are planning to produce at least two charge monitors, one for beam diagnostics, and the other to be used in the Personnel Protection System (PPS) to prevent operation beyond the set charge limit.

**SUMMARY**

Since the first demonstration of the gamma-ray beam in 1996, the HIGS facility has seen a number of upgrades. However, there has not been any significant investment to upgrade the linac pre-injector system, now a critical system which limits the maximum gamma-ray flux above about 20 MeV. Nevertheless, with limited funds, we have been successful in making substantial improvements to linac diagnostics, its charge capability, and operation reliability and safety. One important development is in the area of beam charge monitoring, which has been significantly modified, updated, and integrated into the accelerator control system. Some of these recent upgrades will facilitate increasing the charge injection rate into the storage ring in the near future by operating the linac at a higher repetition rate and/or with a longer electron beam pulse.

**REFERENCES**

- [1] P. G. O’Shea *et al.*, “Radio frequency photoinjector using LaB<sub>6</sub> cathode and a nitrogen drive laser”, *App. Phys. Lett.* **73**, p.411 (1998)
- [2] S. F. Mikhailov *et al.*, “Multibunch injection scheme for the Duke booster synchrotron for top-off injection”, PAC2009, pp.1238-1240 (2009).
- [3] Y. K. Wu *et al.*, “Performance and capabilities of upgraded High Intensity Gamma-ray Source at Duke University”, PAC2009, pp.3181-3183 (2009).

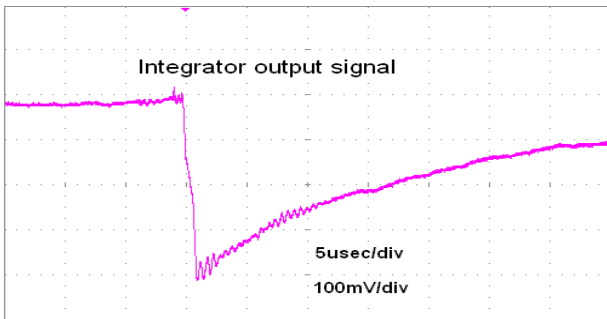

Figure 4. Signal on the output of the integrator.

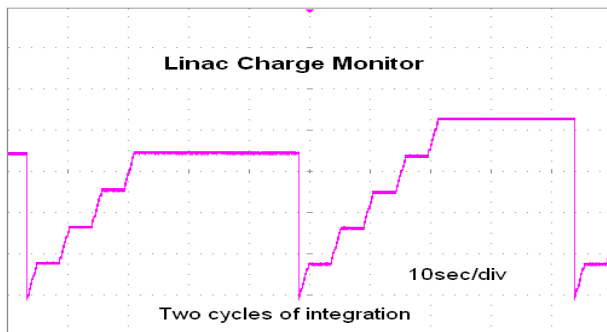

Figure 5. Performance of the linac charge monitor during top-off injection to the storage ring.