



$d(zbport) = 218 \text{ kHz/mm}$ ). Here the positive direction of displacements is inwards of the cavity.

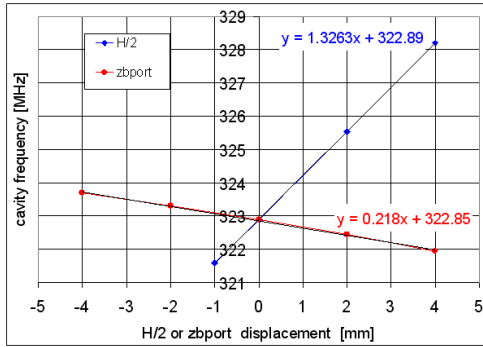

Figure 4: HWR ( $\beta=0.53$ , 322 MHz) simulation results.

Since the sensitivity of the cavity frequency to the HWR length is more than 5 times higher to compare with accelerating gap change, there is an idea to investigate the possibility of the cavity tune by deformation of the dome surfaces but not beam ports.

To allow easier deformations of the dome, the dome geometry has been changed from completely round into mainly plane (Fig. 3, ANSYS geometry). The cone region of the central electrode has been replaced by cylindrical. The deformation of dome plate was simulated with the torus subtraction from HWR volume. The result is  $df / y_{tune} = 536 \text{ kHz/mm}$ .

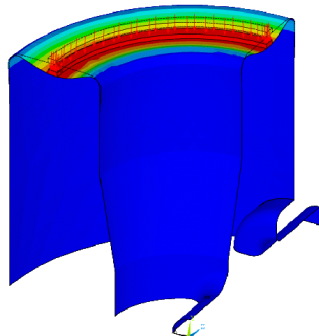

Figure 5: HWR ( $\beta=0.53$ , 322 MHz) dome deformation.

The more realistic simulations of the cavity tune are by the dome region and beam port deformations (Fig. 5).

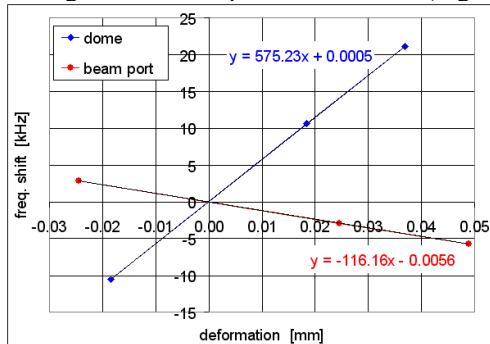

Figure 6: HWR ( $\beta=0.53$ , 322 MHz) tune simulation results.

We applied the tune pressure on the surface of  $dR = 10 \text{ mm}$  wide for dome deformation. It resulted in  $df / dy = 575 \text{ kHz/mm}$ , which is in very good agreement with torus

subtraction simulations). The pressure for beam port deformations was applied on beam pipe aperture. The result is  $df / dz = -116 \text{ kHz/mm}$  (Fig. 6).

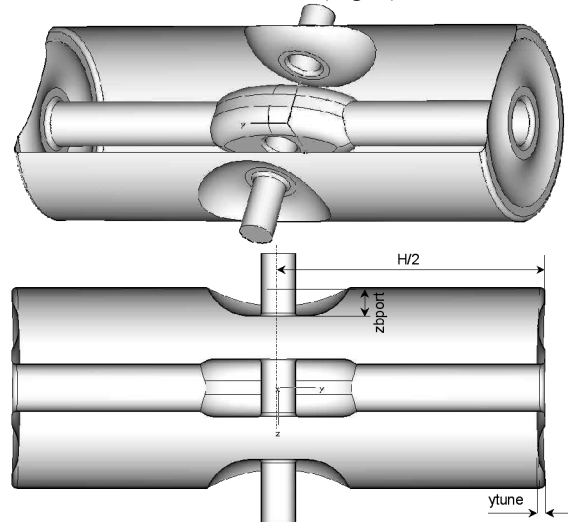

Figure 7: HWR ( $\beta=0.166$ , 175 MHz) tuning by dome deformation.

For HWR with lower  $\beta=0.166$  and frequency 175 MHz (Fig. 7) the frequency dependence on cavity height and accelerating gap length is about the same (Fig. 8). Still the choice can be made in favour of dome tuning option since it allows saving space between cavities along the beam path.

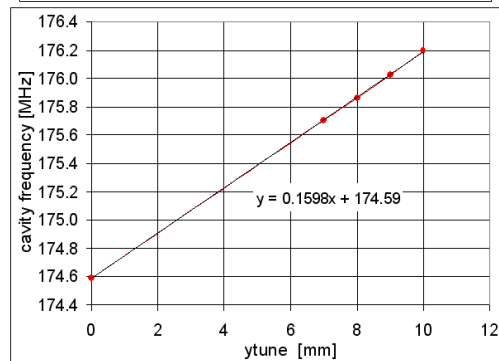
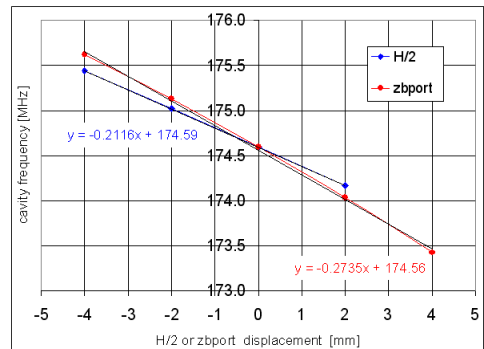

Figure 8: HWR ( $\beta=0.166$ , 175 MHz) tune simulation results.

### SPOKE CAVITY TUNING

The tuning method of spoke cavity is the beam port deformation. This changes a cavity capacitance and shifts

resonance frequency. Since an accelerating gap is the region with the highest electrical field this method results in most effective cavity frequency tune. The frequency shift can be as high as hundreds kHz/mm depending on accelerating gap size. At the same time beam ports are most sensitive places for external pressure or Lorentz force detuning. This forces to stiffen beam ports as much as possible that results in tuning force enhancement. Such contradiction in cavity design can be solved with cavity tuning force applied at the end cup at higher radiuses. This automatically allows the complete beam port stiffening and release additional space between cavities at beam pipe regions. Fig. 10 shows one possible option to stiffen the beam port by ell-ring connected to the helium vessel end flange. The tune force is applied at the end ring.

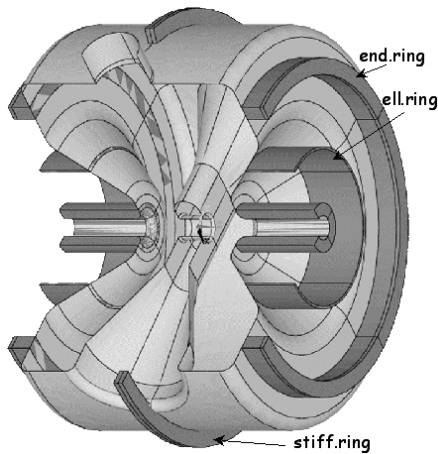

Figure 10: Spoke cavity (325 MHz,  $\beta=0.22$ ).

The resulted deformations for the spoke cavity tune are shown on Fig. 11.

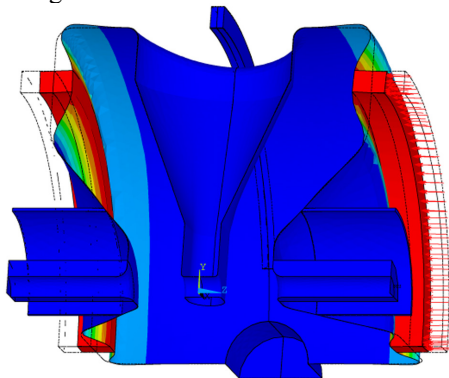

Figure 11: Spoke cavity (325 MHz,  $\beta=0.22$ ) tune deformations.

The tune sensitivity of spoke cavity with resonance frequency 325 MHz and  $\beta=0.22$  is about 320 kHz/mm.

Figs. 12-13 show a spoke cavity (325 MHz and  $\beta=0.1$ ) in the helium vessel with the tune sensitivity by end cup deformation of about 1100 kHz/mm.

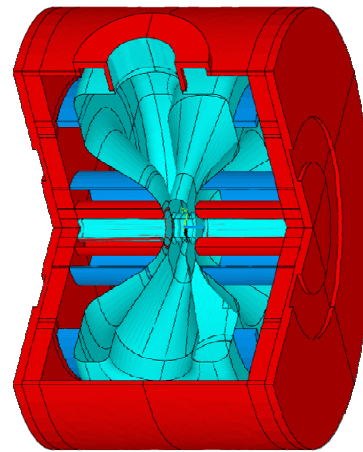

Figure 12: 5-cell cavity with reduced flange thickness region.

For an additional rough cavity frequency adjustment the helium end flange can be used. The flange thickness can be locally reduced for the certain radius range (Fig. 12). Dimensions of the region with reduced thickness should be defined together with the whole cavity-vessel design.

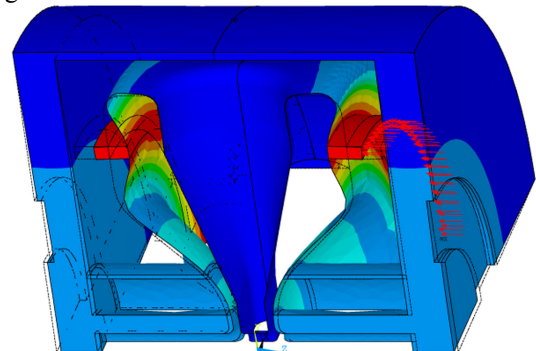

Figure 13: 5-cell cavity with reduced flange thickness region.

Depending on the radius of the cut, the inward force on the cavity walls will be either larger or smaller than the outward force on the end dish. Thus, the cavity will be either shortened or stretched. If to make an initial design with the thickness of this region smaller than it is required, the subsequent bridging of the region with plates of different thickness can provide the final adjustment of the frequency shift. This option can be easily used for subsequent structure adjustment after cavity-vessel fabrication (see also [3]).

## REFERENCES

- [1] T. Jinquera, G. Olry et al., EPAC04, Lucerne, Switzerland, 2004.
- [2] E. Zaplatin et al., "IFMIF-EVEDA SC  $\beta=0.094$  Half-Wave Resonator Study," SRF09, Berlin, Germany, 2009.
- [3] E. Zaplatin, "Project X Elliptical Cavity Structural Analyses," PAC11, New York, USA, 2011.