

# STATUS OF THE MECHANICAL DESIGN OF THE 650 MHz CAVITIES FOR PROJECT X\*

S. Barbanotti<sup>#</sup>, C. Grimm<sup>#</sup>, M. Champion, M. Foley, C.M. Ginsburg, I. Gonin, T. Peterson, L. Ristori, V. Yakovlev, FNAL, Batavia, IL 60510, U.S.A.

## Abstract

In the high-energy section of the Project X Linac [1], acceleration of H- ions takes place in superconducting cavities operating at 650 MHz. Two families of five-cell elliptical cavities are planned: beta = 0.61 and beta = 0.9. A specific feature of the Project X Linac is low beam loading, and thus, low bandwidth and higher sensitivity to microphonics. Efforts to optimize the mechanical design of the cavities to improve their mechanical stability in response to the helium bath pressure fluctuations will be presented. These efforts take into account constraints such as cost and ease of fabrication. Also discussed will be the overall design status of the cavities and their helium jackets.

## INTRODUCTION

The proposed design of the 3 GeV Project X superconducting (SC) Linac employs 650 MHz five-cell elliptical cavities to accelerate 1.0 mA of average H-beam current in the 160-3000 MeV energy range [1]. The 650 MHz region of the Linac is divided into two sections with two different geometric phase velocity factors: beta=0.61 to cover the 160-520 MeV range and beta=0.9 to cover the 520-3000 MeV range. Approximately 40 beta=0.61 and 150 beta=0.9 cavities are currently planned for the project.

An R&D program is in progress at FNAL, in collaboration with TJNAF and India, to develop the 650 MHz cavities for the proposed Linac design. This R&D program includes the design and fabrication of several beta=0.61 and 0.9 single-cell prototypes for evaluation prior to production of the five-cell cavities. FNAL has contracted AES to fabricate the beta=0.9 prototypes, while TJNAF is building beta=0.61 prototypes of their own design. In the remainder of this paper we will restrict our discussion to the five-cell beta=0.9 cavities.

## BETA = 0.9 FIVE-CELL CAVITY

### Cavity RF Design

The cavity layout is shown in Figure 1, and the dimensions are listed in Table 1[2]. The RF parameters are presented in Table 2.

A feature of the Project X Linac is minimal beam loading, and thus narrow cavity bandwidth. The bandwidth of the matched 650 MHz cavities (for the gain per cavity specified in Table 2) and the beam current of 1.0 mA is ~25 Hz. That creates problems with microphonics (discussed in detail in [3]).

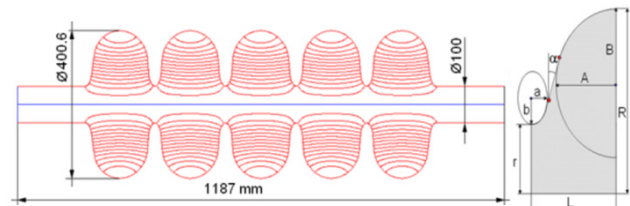

Figure 1: Layout of 650 MHz, beta=0.9 cavity.

In order to mitigate microphonics, it is necessary to increase the mechanical stability of the cavity versus the helium bath pressure fluctuations: i.e., decrease the value of  $df/dP$  ( $f$  is the cavity resonance frequency and  $P$  is the helium bath pressure).

Table 1: Dimensions of the 650 MHz, Beta=0.9 Cavity.

| Dimension    | Regular cell | End cell |
|--------------|--------------|----------|
| r, mm        | 50           | 50       |
| R, mm        | 200.3        | 200.3    |
| L, mm        | 103.8        | 107.0    |
| A, mm        | 82.5         | 82.5     |
| B, mm        | 84           | 84.5     |
| a, mm        | 18           | 20       |
| b, mm        | 38           | 39.5     |
| $\alpha$ , ° | 5.2          | 7        |

Table 2: RF Parameters of the 650 MHz, Beta=0.9 Cavity.

|                                     |      |
|-------------------------------------|------|
| Beta                                | 0.9  |
| R/Q, Ohm                            | 638  |
| G-factor, Ohm                       | 255  |
| Max. gain per cavity, MeV(on crest) | 17.5 |
| Gradient, MeV/m                     | 16.9 |
| Max. surf. electric field, MV/m     | 33.7 |
| $E_{pk}/E_{acc}$                    | 2    |
| Max surf. magnetic field, mT        | 63   |
| $B_{pk}/E_{acc}$                    | 3.75 |

Another possible problem is higher order modes (HOM's). To suppress them, special HOM dampers are typically used. However, HOM dampers are an expensive and complicated part of a SC acceleration structure, and can create different problems: multipacting, leak of the operating modes, etc. Also, HOM dampers require additional hardware. Experience with the existing SNS proton SC Linac shows that HOM dampers may cause cavity performance degradation during long-term operation [4]. On the other hand, the SNS Linac experience does not demonstrate the necessity for HOM couplers. Simulations show that the probability of collective instabilities in the CW Linac is very small [5], and that the risk of the resonance HOM excitation is minimal for the design beam current [6]. However, possible problems may arise in the case of a future Linac upgrade to higher current. A solution to mitigate the risk

\*Operated by Fermi research Alliance, LLC under Contract No. DE-AC02-07CH11359 with the United States Department of Energy #serenab@fnal.gov; grimm@fnal.gov

may be to utilize two additional sealed ports 40 mm in diameter without HOM dampers, see Fig. 2.

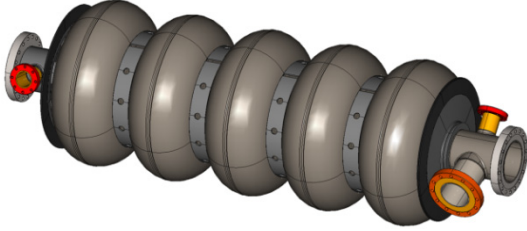

Figure 2: 650 MHz  $\beta=0.9$  5-cell cavity shown with HOM dampers

### Cavity Mechanical Design

The preliminary design of the  $\beta=0.9$  five-cell cavity was outlined in the paper presented at the Linac 2010 conference [2]. At that time efforts were still in progress to finalize the design of the helium vessel and minimize the resultant magnitude of  $df/dP$ . Numerical simulations performed since then indicate that locating the stiffening rings at a radius of 141 mm from the cavity axis is the optimal location for minimizing the magnitude of  $df/dP$  for a dressed cavity.

### Helium Vessel Design

The helium vessel assembly is constructed using two 5mm thick titanium tubes with a titanium bellows assembly between the tube sections to accommodate a slow tuner. Two circumferential full penetration TIG welds complete the tube assembly as shown in Figure 3.

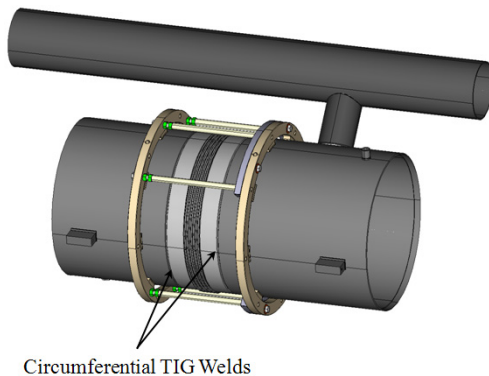

Figure 3: He vessel assembly.

The inside diameter of the tubes is approximately 441mm. Each tube is constructed using a spin forming process that creates a seamless titanium tube from a standard 5mm thick flat plate. The 2-phase pipe sizes were determined by the cryogenic system requirements for a cryomodule.

All of the weld joint designs on the helium vessel satisfy the ASME Boiler & Pressure Vessel Code Section VIII Division 2. It is important to note that the 5 mm wall thickness for the helium vessel specification was not because of the ASME code, but rather to help in reducing  $df/dP$  by using the helium vessel to help stiffen the cavity.

The main coupler end and the field probe end of the helium vessel have slightly different joint designs due to

the cavity installation sequence and variations in cavity lengths as described later. The main coupler end of the vessel is considered a fixed position relative to the main coupler port of the cavity, and consistency between these key features for dressed cavities is maintained. Figure 4 shows the titanium-to-titanium TIG welded connection between the cavity and helium vessel at the main coupler end. This joint design utilizes a backing ring and satisfies the ASME code.

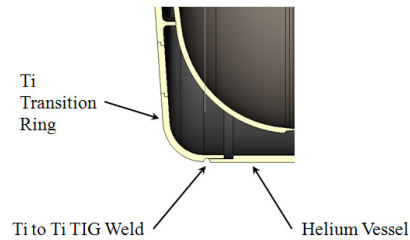

Figure 4: He vessel to cavity fixed joint design.

To allow for variations in the lengths of the manufactured cavities, the field probe end required a sliding joint design that would allow cavity insertion into the helium vessel from the field probe end to the main coupler end. As shown in Figure 5, cavities that vary by  $\pm 10$ mm in length will not have any effect on the single vessel design. This joint will also satisfy the ASME code.

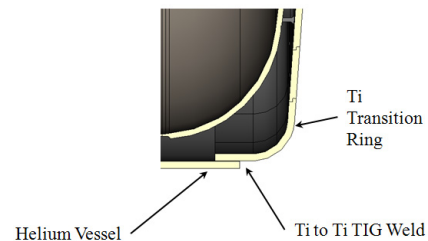

Figure 5: He vessel to cavity sliding joint design.

### Dressed Cavity Pressure Boundary

Where practical, the overall cavity design must adhere to the ASME Boiler and Pressure Vessel code. The pressure boundary will consist of the cavity cell walls, the connecting flanges and conical disks, and the helium vessel. See Figure 6.

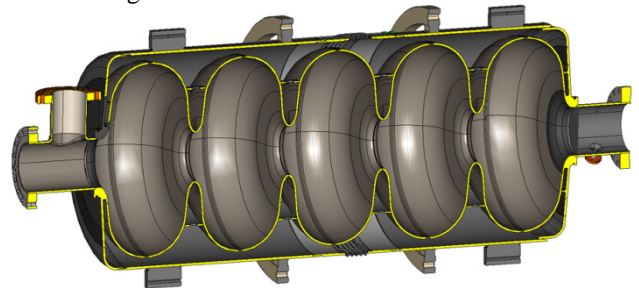

Figure 6: Pressure boundary of the dressed cavity shown in yellow.

All electron beam (EB) welds within the pressure boundary defined above are required to have a fully consumed joint; i.e., dual pass with full overlap or full penetration.

A critical joint is located where each end half-cell is EB welded to its connecting flange (Figure 7). Both sides of the joint are weld prepped to 2.0 mm wall thickness. A finite element simulation has verified that the resultant stress distribution in this region is not an issue.

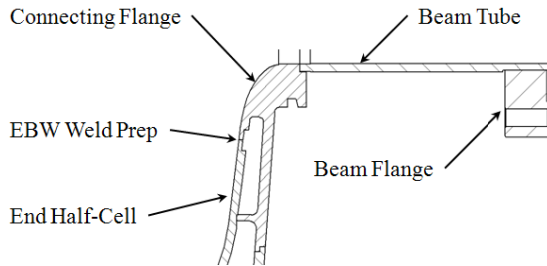

Figure 7: End half-cell to connecting flange joint showing 2mm EBW weld prep.

**RF and Mechanical Analysis**

A set of mechanical simulations (modal analysis, thermal analysis of critical areas, stress evaluations under working pressure) have been performed on the preliminary design of the beta=0.9 cavity and the results have been summarized in [2].

After the publication of that paper, some parameters have been fixed and the RF/mechanical simulations to estimate the  $df/dP$  of the cavity with the helium vessel, as in the present design, have been performed. The modal and thermal analyses have not been updated, since no major changes have occurred to the design.

Table 3 lists the updated requirements in terms of cavity maximum detuning allowed while keeping the cavity frequency within the bandwidth limits.

Since the cavities will be operated in CW mode, microphonics due to the expected level of pressure fluctuations in the helium bath will be the dominant detuning factor. Lorentz force detuning does not appear to be a primary issue.

Table 3: Tuning Requirements

|                                     | <b>Beta = 0.9</b> |
|-------------------------------------|-------------------|
| He pressure fluctuations (mbar)     | ±0.13             |
| Bandwidth (Hz)                      | 40                |
| Maximum Microphonics amplitude (Hz) | 20                |
| Maximum $df/dP$ (Hz/mbar)           | 25                |
| MAWP, warm / cold (bar)             | 2 / 2.5           |

With the present cavity and helium vessel design, the calculations show that a  $df/dP$  of about 4.5 Hz/mbar can be reached. The volume variation induced by a 1.0 bar internal pressure and the RF distribution inside the cavity determine the frequency shift due to pressure fluctuations.

The preliminary stress analyses have been updated and do not show any critical region. For an internal pressure of 2 bar and room temperature material properties, the Von Mises stresses are above the niobium critical value of

37.9 MPa (FNAL specification) only in localized regions in the end ring area (Figure 8), connecting the end cells to the beam pipe. These regions have been investigated by calculating the linearized stresses using the procedures defined in the ASME Pressure Vessel code. The results do not indicate any concern.

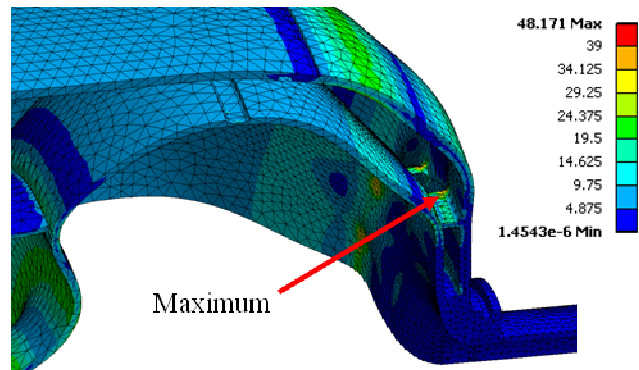

Figure 8: Von Mises stresses inside the cavity for 2.0 bar internal pressure.

**CONCLUSIONS**

A complete set of engineering drawings for the fabrication of several prototype 650 MHz five-cell beta=0.9 cavities is in preparation. Evaluation and testing of the prototype cavities will yield information necessary to finalize the design for Project X.

The issue of whether the prototype cavities will have HOM dampers, sealed HOM damper ports, or no HOM dampers is still under discussion at FNAL.

**ACKNOWLEDGEMENT**

The authors would like to acknowledge the valuable assistance of Bob Wands for verification of the mechanical finite element simulations referenced above.

**REFERENCES**

- [1] S. Nagaitsev, "Project X – New Multi Megawatt Proton Source at Fermilab," this Conference, FROBN3.
- [2] S. Barbanotti, I. Gonin, C. Grimm, T. Khabibouline, M. Foley, L. Ristori, N.Solyak, V. Yakovlev, "Status of the design of 650 MHz elliptical cavities for project X", Linac 2010, Tsukuba, 2010
- [3] W. Schappert et al., "Microphonics in the CW Project X Linac," this Conference, TUP086.
- [4] S.-H. Kim, "HOM Experiences at the SNS SCL," SPL HOM Workshop, CERN, 2009.
- [5] N. Solyak et al., "Longitudinal and Transverse Effects of HOMs in the Project X Linac," IPAC2010, Kyoto, 2010, p.1369.
- [6] V. Yakovlev et al., "HOMs in the Project X Linac," This Conference, TUP088.