

RF AND STRUCTURAL ANALYSIS OF THE 72.75 MHz QWR FOR THE ATLAS UPGRADE*

T. Schultheiss, J. Rathke

Advanced Energy Systems, 27 Industrial Boulevard, Unit E, Medford, NY 11763 USA

J. Fuerst, M. Kelly, P. Ostroumov

Argonne National Laboratory, Argonne, IL 60439 USA

Abstract

An energy upgrade to the heavy-ion accelerator ATLAS at Argonne Lab is progressing [1,2]. The plans include replacing split-ring cavities with high performance quarter wave resonators. The new 72.75 MHz resonators are designed for optimum ion velocity $\beta=0.77$ and a record high accelerating voltage of 2.5 MV by modifying the top geometry and reducing the peak surface fields. This new cavity has a longer center conductor than the 109 MHz cavities previously built by ANL with AES assistance, this and the other geometry changes add new engineering requirements to the design. This paper presents the engineering studies that were performed to resolve new issues. These studies include determining structural frequencies of the center conductor and stiffening methods, resonator frequency sensitivity to helium pressure fluctuations, and determining stress levels due to pressure and slow tuning. Evaluation of fast piezoelectric tuner frequency shift to tuner load was also performed and the local cavity shape was optimized based on these results.

vacuum manifold. There is also a port into the helium vessel for cavity cool down flow. Coupling ports provide access for high pressure water rinsing and are structurally isolated from the helium vessel using bellows.

STRUCTURAL FREQUENCIES OF THE CENTER CONDUCTOR

On the right of Figure 1 is a section cut showing the niobium internal geometry. This E-M optimized design results in a longer center conductor than the 109 MHz QWR. Natural frequencies of the center conductor were determined and stiffness was added by adding additional ribs between the titanium plate and the niobium as well as increasing the size of the titanium plate. The lowest structural frequency was determined to be about 66 Hz in a pendulum mode. Microphonics testing at Argonne [3] has shown that this frequency is acceptable. There is a plan to add a passive mechanical vibration damper.

QWR GEOMETRY

The geometry of the quarter wave resonator is shown in Figure 1. On the left of the figure is the helium vessel with brackets for lifting and securing. The conical shape for the SS shell was adopted to meet stress allowable for the 40 psi design pressure condition. On top there are two coupling ports into the cavity, one of which is used for the RF pickup loop. There is also a port into the helium vessel that connects to the helium supply/return manifold. On the bottom there are two coupling ports into the cavity; one for the input coupler and one for the cavity

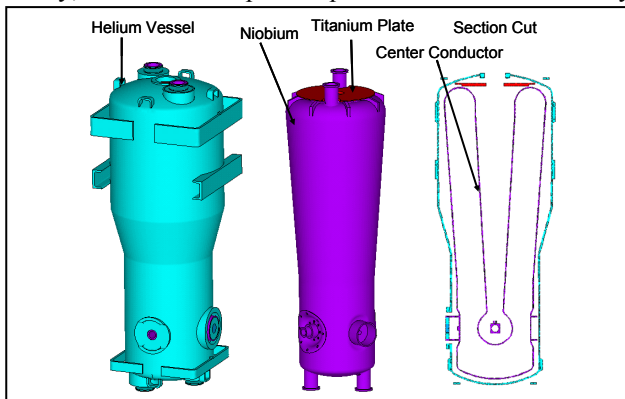

Figure 1: Quarter wave resonator geometry.

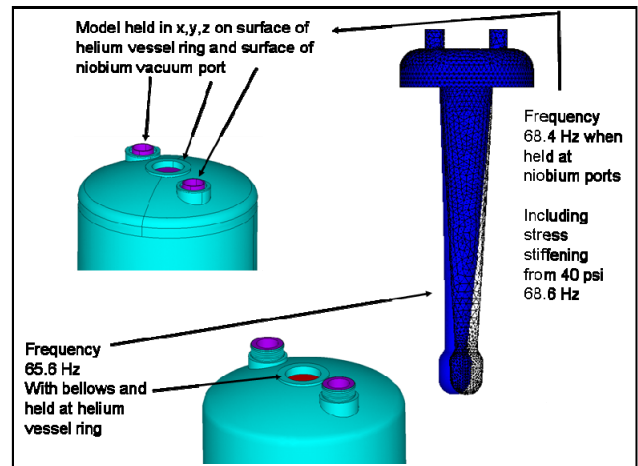

Figure 2: Structural frequencies of the center conductor.

FREQUENCY SENSITIVITY TO HELIUM PRESSURE

The high loaded Q of these superconducting cavities results in a very narrow frequency bandwidth. This requires sophisticated and precise control of the resonator frequency. In 4K helium systems helium pressure variation can vary the resonator frequency, therefore, determination of the frequency sensitivity to helium pressure and minimizing this sensitivity is vital. The structural model to determine this sensitivity must include the helium vessel and all the features on the vessel and niobium cavity that influence its stiffness. Figure 3 shows the distorted shape of the cavity with a 40 psi pressure

* This work was supported by Argonne National Lab under contract numbers OF-32381 & OF32422.

load in the helium volume. The shape on the left is a section cut through the beam line and the shape on the right is 90 degrees from the beam line and is a cut through the center of the fast tuner. The dashed black lines show the original cavity shape while the purple solid lines show the distorted shape. A look at the top of the cavity shows that pressure within the center conductor moves the center conductor downward. This can be seen in both the left and right graphics. At the bottom left the graphic shows that the cavity stays in the center of the beam pipe flanges. However, on the right the cavity is shown to move toward the tuner side. This is due to a bellows in the fast tuner design, however, the distortion scaling is 95 and the actual distortion is relatively small resulting in a frequency sensitivity of -1.19 kHz/atm.

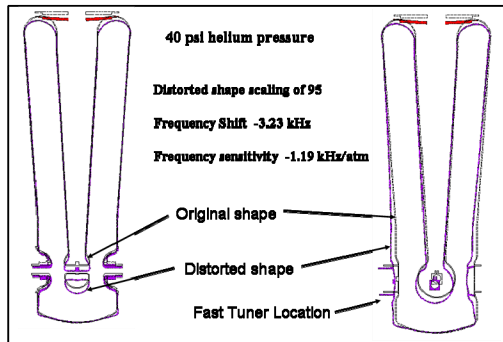

Figure 3: Helium pressure sensitivity.

STRESS LEVELS DUE TO PRESSURE AND SLOW TUNING

The design pressure is set by the operation of the cryogenic system and the pressure relief valve. Stresses were determined in the helium vessel and the niobium assuming a helium pressure of 40 psi. Figure 4 shows the von Mises stress in the helium vessel resulting from this helium pressure. The only significant model stress is in a weld region at a corner of a lifting flange. The model stress over predicts the stress at this location because the weld material is not included in the model.

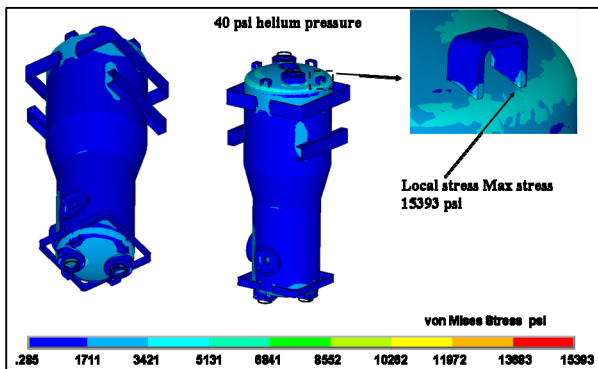

Figure 4: Pressure stresses in helium vessel.

When comparing the model stresses to yield stress the operation of the system must be considered and the appropriate material temperature must be used for comparison. In general the conditions of over pressure

could occur during cryogenic cooling with the structure at or near room temperature, and since room temperature strength limits (i.e., yield and ultimate), are lower than cryogenic limits the room temperature limits were used. Figure 5 shows the stresses in the niobium cavity. The only significant stress is in a corner between the tuning ring stiffener and the cavity wall. Though this stress is over yield it is local, the material will yield and the loads will redistribute. This stress is considered acceptable.

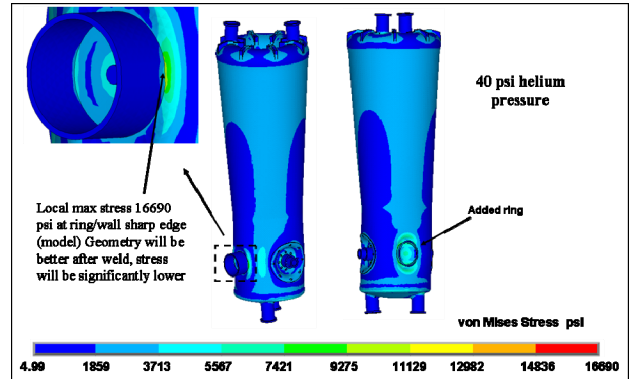

Figure 5: Pressure stresses in niobium cavity.

A slow or coarse tuner is applied to the outside of the helium vessel around the outside of the beam tube. Figure 6 shows the stresses in the helium vessel from the slow tuner loads. The loads are applied on the upper and lower surfaces of the flange on both sides of the cavity. Stresses above 20000 psi are shown in the upper and lower corner of the flanges. These stresses are local and are below the yield strength of stainless steel.

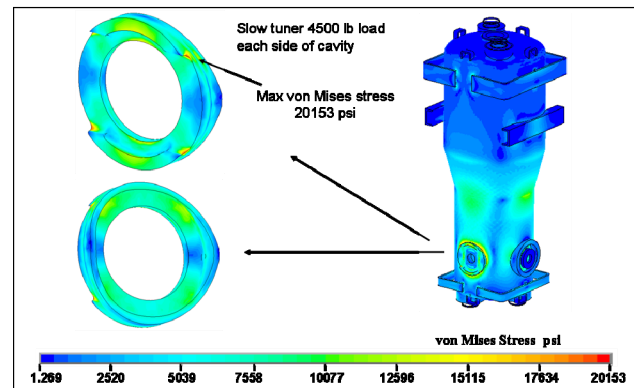

Figure 6: Slow tuning stresses.

EVALUATION OF PIEZOELECTRIC TUNER FREQUENCY SHIFT

The piezoelectric tuner is a fast mechanical tuner that depresses the side of the cavity wall. This type of tuning is insensitive to the cavity field level. The tuner was developed at Argonne [4] using Noliac SCMAP09 stacks. This paper focuses on the local cavity geometry and its interaction with the tuner loads to produce a frequency shift. Figure 7 shows the model and local tuner geometry. In the model the tuner is simplified to the action of a gap element. At one end it is attached to the niobium button

and at the other end it is attached to a stainless steel flange. This flange is attached to the niobium ring. Holes in the tuner ring allow the helium bath to be in the tuner region and on the tuner button. The gap element includes its own compression-only stiffness and initial interference can be used to simulate the tuner stroke.

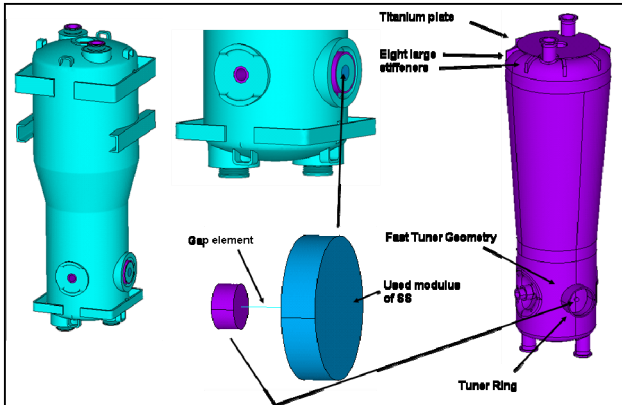

Figure 7: Modeling of piezo-electric tuner.

Initial cavity geometry was set with the tuner ring 90 degrees from the beam ports and a tuner button on the curved surface of the cavity. Figure 8 shows the resulting displacements. With a tuner stroke of 20 microns the frequency shift is only -3.6 Hz. This result is not acceptable to the design goals. This poor performance was due to the curvature of the cavity inside the tuner ring.

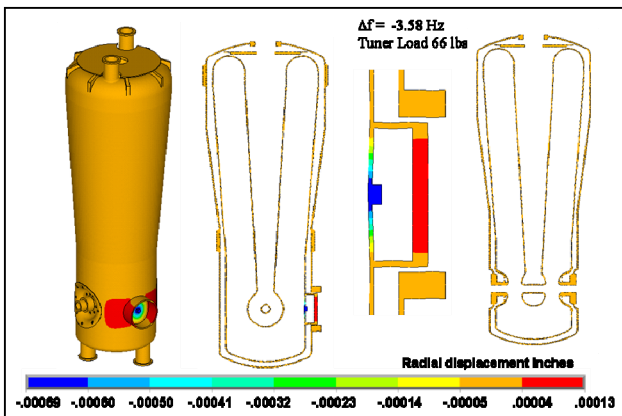

Figure 8: Results of piezo-electric tuner with curved cavity wall.

A flat surface was then designed into the cavity to soften the local stiffness and to isolate the tuner displacements from cavity locations outside the tuner ring. Figure 9 shows the flat in the cavity and the tuner displacements. With the added flat a cavity frequency shift of -46 Hz from 42 pounds of tuner load was achieved.

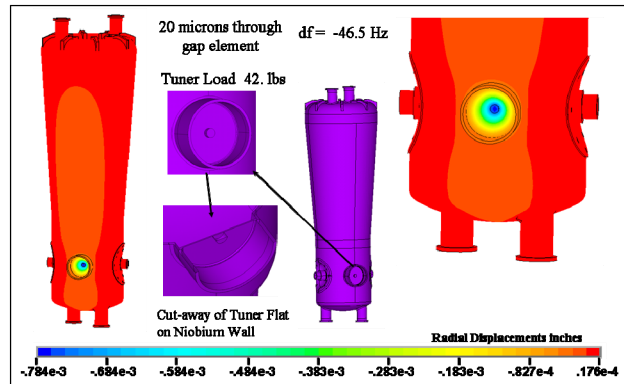

Figure 9: Cavity displacements from piezoelectric tuner.

CONCLUSIONS

Detail engineering studies were performed on the 72.75 MHz Quarter-Wave-Resonator for the ATLAS upgrade. The added length of the center conductor showed acceptable structural frequencies. Slow tuning stresses were confined to local regions as well and are acceptable. Evaluation of the fast tuner led to a modification of the niobium cavity shape to a local flat face resulting in an increased fast tuner frequency range. ANL tests of the prototype cavity have confirmed the engineering design. The cavity was built to meet ASME pressure vessel code, the slow tuner provides the expected range of frequency tuning, the measured pressure sensitivity is higher than the design but the absolute value is small and controllable. The details of the cavity tests are reported at this conference [7].

REFERENCES

- [1] P.N. Ostroumov et al, "A New Atlas Efficiency and Intensity Upgrade Project," SRF2009, Berlin, Germany, TUPPO016, p. 218 (2009); <http://www.JACoW.org>.
- [2] P.N. Ostroumov et al., "Efficiency and Intensity Upgrade of the ATLAS Facility," LINAC 2010, Tsukuba, Japan, MOP045, to be published.
- [3] M.P. Kelly et al., "Microphonics in the ATLAS Upgrade Cryomodule," SRF 2009, Berlin, Germany, TUPPO031, p. 269 (2009); <http://www.JACoW.org>.
- [4] P. Kelly et al., "A New Fast Tuning System for ATLAS Intensity Upgrade Cryomodule," LINAC2010, Tsukuba, Japan, THP057, to be published.
- [5] B. Mustapha et al., "Electro-Magnetic Optimization of a Quarter-Wave Resonator," LINAC2010, Tsukuba, Japan, THP057, to be published.
- [6] P.N. Ostroumov et al., "Commissioning of the ATLAS Upgrade Cryomodule," HIAT09, Venice, Italy, TH-02, p. 151 (2010); <http://www.JACoW.org>.
- [7] M.P. Kelly et al., "Superconducting Beta=0.77 Quarter-Wave Cavity for ATLAS," PAC2011, New York, NY, TUP046, these proceedings.