

# BEAM DYNAMICS SIMULATIONS AND MEASUREMENTS AT THE PROJECT-X TEST FACILITY\*

E. Gianfelice-Wendt<sup>†</sup>, V.E. Scarpine, R.C. Webber, Fermilab, Batavia, IL 60510, USA

## Abstract

Project X, under study at Fermilab, is a multitask high-power superconducting RF proton beam facility, aiming to provide high intensity protons for rare process experiments and nuclear physics at low energy, and simultaneously for the production of neutrinos, as well as muon beams in the long term. A beam test facility - former known as High Intensity Neutrino Source (HINS) - is under commissioning for testing critical components of the project, e.g. dynamics and diagnostics at low beam energies, broadband beam chopping, RF power generation and distribution. In this paper we describe the layout of the test facility and present beam dynamics simulations and measurements.

## INTRODUCTION

The former HINS, now Project-X Test Facility, has undergone various changes following the evolution of the Fermilab intensity frontier plan, which now calls for a 3 GeV CW SRF linac with 1 mA average current (about 80 % chopped beam, 5 mA bunch current), followed by a 3-8(6) GeV pulsed SRF linac, with up to 4 % duty cycle [1].

The Test Facility main goals are:

- Demonstrate beam acceleration using superconducting spoke type cavity structures.
- Demonstrate the use of high power RF vector modulators to control multiple RF cavities by a single high power klystron for acceleration of a non-relativistic beam.
- Demonstrate beam halo and emittance growth control by the use of solenoidal focusing.
- Demonstrate broadband beam chopping technologies for 162.5 and/or 325 MHz bunched beams of 2-2.5 MeV.

## PX TEST FACILITY LAYOUT

The original Project-X Test facility layout includes a  $H^-$  source, a Low Energy Beam Transport (LEBT) section, a 2.5 MeV RFQ, a Medium Energy Beam Transport (MEBT), and the possibility for either a room temperature RF section or a superconducting single spoke resonator cry-omodule for further acceleration. More details on the test facility are given in [2].

Until recently the Project X Test Facility consisted out of a 50 keV proton source, followed by a LEBT, injecting into a 325 MHz 2.5 MeV pulsed RFQ. First beam measurements are reported in [3].

The following MEBT section has been extended with a section including 3 quadrupoles and a spectrometer magnet, and is equipped with various beam diagnostics to tune the machine and quantify the beam parameters.

The complete proposed layout of the MEBT section is shown in Fig. 1, while Fig. 2 shows the current status of the facility.

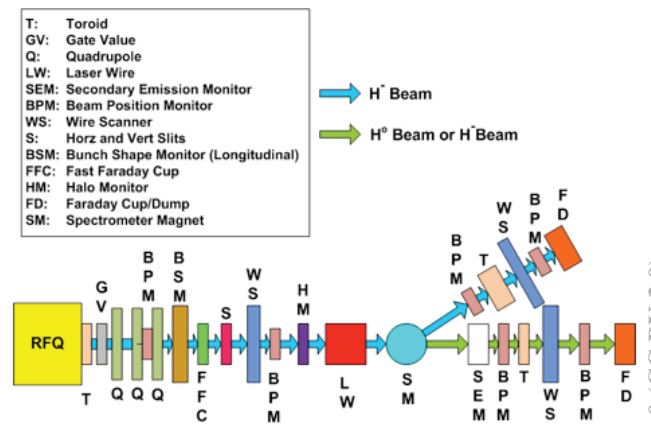

Figure 1: Layout of the PX-Test facility beam line.

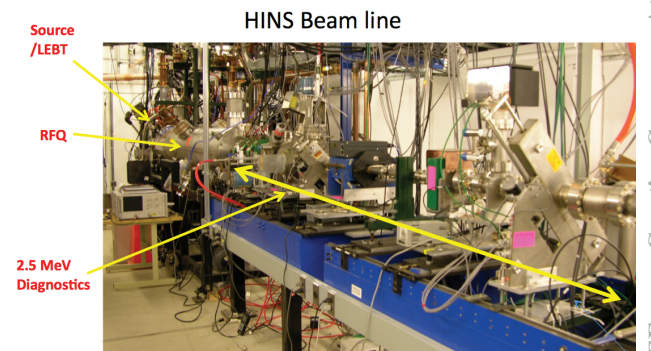

Figure 2: Current layout of the PX-Test facility beam line.

## Energy and Energy Spread Measurement

Initially RFQ beam energy was intended to be measured from the time-of-flight between two BPMs downstream the RFQ. The continuous nature of the beam through the RFQ make this impossible, unless the RFQ is purposely sparked to kill the beam quickly and generate a sharp beam edge

\* Work supported by Fermi Research Alliance LLC. Under DE-AC02-07CH11359 with the U.S. DOE

<sup>†</sup> eliana@fnal.gov

visible in both BPMs. This has been indeed done in past measurements [3].

The MEBT line will be equipped with a spectrometer magnet and the beam energy will be just measured from the position of the center of the deflected beam measured by a Wire Scanner (WS). This kind of measurement should not pose problems.

The possibility of measuring, in addition, the energy spread of the beam has been studied in detail.

The beam size includes two terms

$$\sigma = \sqrt{\epsilon\beta + D^2 \left(\frac{\Delta p}{p}\right)^2} \equiv \sqrt{\sigma_\beta^2 + \sigma_p^2} \quad (1)$$

If, for instance, a horizontal dipole is introduced downstream the RFQ for creating horizontal dispersion, the energy spread may be measured from the beam size.

Owing to the fact that the WS measures the beam total width, this would require the knowledge of horizontal emittance and betatron function at the WS location. In order to simplify the data analysis, we have looked at the possibility of avoiding having such information by a proper optimization of the experimental beam line.

From Eq.(1) it is clear that the best location for the WS is where  $\sigma_{x,p}^2/\sigma_{x,\beta}^2$  is maximum.

The three quadrupoles at the RFQ exit therefore must provide a minimum of  $\beta_x$  at the WS while a relatively strong dipole ensures large horizontal dispersion at the WS location. With the same bending angle a sector magnet is more convenient as it provides extra horizontal focusing. The dispersion downstream the dipole is

$$D = D_0 + D'_0 s$$

with (sector magnet)

$$D_0 = \rho(1 - \cos \phi_b) \quad \text{and} \quad D'_0 = \sin \phi_b$$

$D_0$  and  $D'_0$  being the values of dispersion and its derivative at the exit of the dipole. Therefore large  $\phi_b$  and  $\rho$  are preferred. The focusing being  $M_{21} = -\sin \phi_b/\rho$ , the bending radius is determined by a balance between focusing and dispersion.

Moreover the dipole minimum horizontal aperture,  $\delta = \rho[1 - \cos(\phi_b/2)]$ , limits how large may be the bending radius chosen. At the Project-X test facility, logistic reasons limit the bending angle to about  $30^\circ$ ; moreover for obvious economic reason, we would like to make use of one of the many magnets already available in storage.

### Optics Optimization for Energy Spread Measurement

The program currently used for matching the Project-X linac, TraceWin [4], does not distinguish between betatron and synchrotron motion. This makes our optimization cumbersome. Therefore, as the part of the line under consideration does not include RF cavities, we have preferred to carry out the optics optimization with MAD-X.

Sets of values for the three quadrupoles may be found depending on the ratio  $\sigma_{x,p}^2/\sigma_{x,\beta}^2$  and the tolerated overall maximum  $\beta_x$  and  $\beta_y$  we are asking for.

After ruling out some magnet ‘‘candidates’’ as too weak, the choice is fallen on an existing 0.306 m long sector magnet. With  $\hat{B}=0.29$  T, it provides  $\phi_b=22^\circ$  at 2.5 MeV. The width of the magnet, 100 mm, is large enough to let the unbend beam go through. Fig. 3 shows the Twiss functions and the horizontal dispersion starting from RFQ exit; the middle of the spectrometer magnet is at 1.94 m and the WS is at 4.44 m. After optimization, at the WS it is  $\beta_x=0.643$  m,  $D_x=0.954$  m and  $\sigma_{x,p}^2/\sigma_{x,\beta}^2 \simeq 4$ .

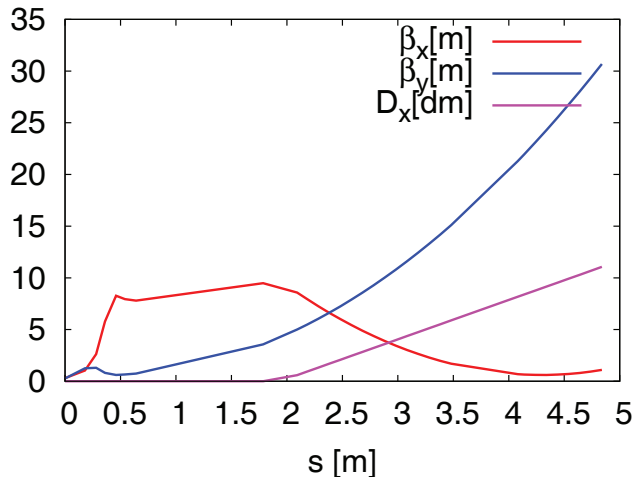

Figure 3: MAD-X Twiss functions and dispersion.

### Energy Spread Measurement Simulation

The resulting quadrupole strengths are introduced in the TraceWin beam line input for simulating the measurement process. Fig. 4 shows the  $3\sigma$  horizontal (top), vertical (middle) and longitudinal (bottom) envelopes computed by TraceWin between RFQ exit and WS.

The tracking includes space charge. The beam current is 5 mA. The (nominal) starting normalized emittances and Twiss parameters are quoted in Table 1.

Table 1: Starting Twiss Parameters and Normalized Emittances

	$x$	$y$	$z$
$\beta$ (m)	0.30	0.27	0.69
$\alpha$	-1.27	-1.57	-0.20
$\epsilon_N$ (mm mrad)	0.25	0.25	0.49

The horizontal beam size at the WS computed by TraceWin for  $I=0$  mA is 3.398 mm. and expected  $\Delta p/p$  is  $3.207 \times 10^{-3}$ . Thus when using Eq.(1) for determining the energy spread ignoring the betatron contribution the error is about 11%.

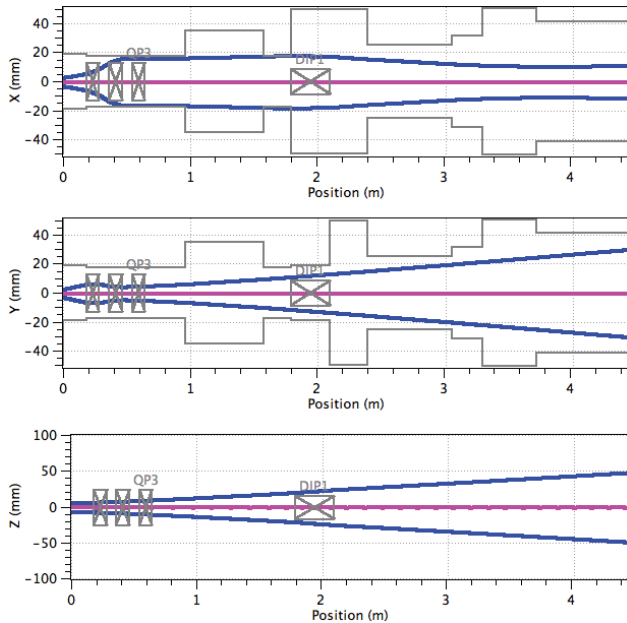

Figure 4:  $3\sigma$  envelope computed by TraceWin for  $I=5$  mA.

With  $I=5$  mA the expected  $\Delta p/p$  and  $\sigma_x$  at the WS are  $3.565 \times 10^{-3}$  and 3.759 mm respectively. The error is similar as without space charge.

We have tried improving the error by inserting a slit upstream of the dipole for cutting away particles with large horizontal offset. Of course, particles having a small offset but large angle at the slit will make their way to the WS and the error may even increase. A second slit at  $\pi/2$  horizontal phase advance could help, but it would make the beam line un-feasible long.

Fig. 5 shows again TraceWin computed  $3\sigma$  horizontal (top), vertical (middle) and longitudinal (bottom) envelopes in the presence of a 30 mm long slit just in front of the dipole, with a width of  $\pm 5$  mm. 40% of the beam is intercepted by the slit. The marginal improvement (error is reduced to 8%) is likely in the “noise” of the simulation.

## SUMMARY AND OUTLOOK

Initial beam measurements have been made on the Project-X Test Facility RFQ. These basic measurements indicate that the RFQ is operating within the design specifications. However, additional improved measurements will be needed to characterize fully the RFQ. Among those, we propose the insertion of a relatively strong dipole magnet in the MEBT line for measuring beam energy spread, in addition to beam energy. For this measurement, however, the beam line optics must be changed by using the three quadrupoles at the exit of the RFQ.

## ACKNOWLEDGMENTS

The help of B. Hanna who provided us with the spectrometer magnet and its parameters is warmly acknowledged.

Sources and Medium Energy Accelerators

Accel/Storage Rings 15: High Intensity Accelerators

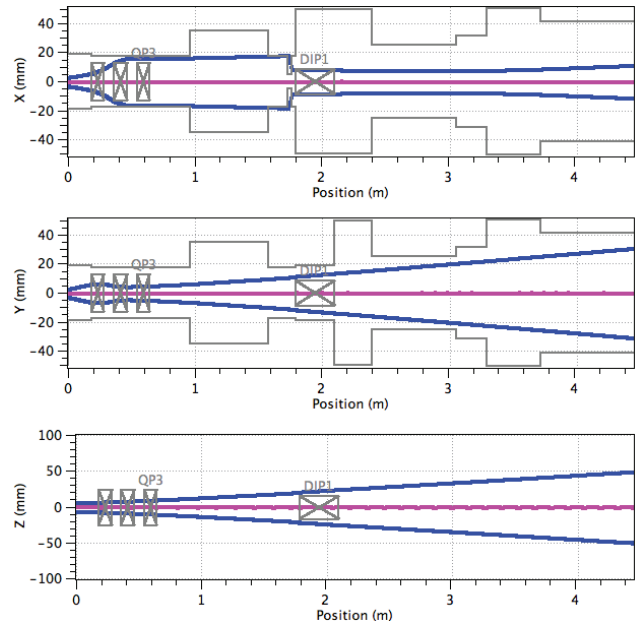

Figure 5:  $3\sigma$  envelope computed by TraceWin for  $I=5$  mA with closed slit.

## REFERENCES

- [1] S. Nagaitsev et al., “Project X - New Multi Megawatt Proton Source at Fermilab”, these proceedings.
- [2] J. Steimel et al., “Status and specifications of a Project X front end accelerator test facility at Fermilab”, these proceedings.
- [3] V.E. Scarpine et al., Proc. BIW10, p.359.
- [4] D. Uriot, CEA, France, didier.uriot@cea.fr, <http://irfu.cea.fr/Sacm/logiciels/index3.php>.