

RF GUN WATER TEMPERATURE CONTROL SYSTEM AT ASTA *

P. Stabile[#], M. Ball, J. Czajkowski, J. Firebaugh, P. Kasley, P.S. Prieto, T. Zuchnik,
Fermilab, Batavia, IL, 60510, USA

Abstract

A linear electron accelerator is in the late stage of construction at the Advanced Superconducting Test Accelerator (ASTA) facility at Fermilab. The purpose of this accelerator is to operate, study and develop the superconducting cavities and associated systems to be used in future superconducting accelerators. ASTA incorporates an L-band radiofrequency (RF) gun with a coaxial RF input operation at 1.3GHz, based on 1+1/2 cell DESY-type gun, followed by two superconducting cavities. A temperature control system regulates the RF power transmission between 5MW Klystron and the RF Gun. Its role is to maintain the resonant frequency by exploiting the 16.5ppm/°C thermal expansion of the copper. Temperature is regulated by mixing chilled low conductivity water (LCW) with circulating water between the cavity and gun skid located outside the radiation cave. A fine pneumatic actuated valve controls the chilled water flow and in turn is controlled by a feedforward/feedback regulation algorithm. This paper will describe the water temperature control system used to stabilize the tuning frequency of the RF Gun.

INTRODUCTION

Fermilab is constructing ASTA at the existing New Muon Lab (NML) building. ASTA is part of Fermilab new state-of-the-art superconducting radio frequency (SRF) test facility complex. ASTA facility [1] consists of a shielding cave which houses the accelerator, as well as areas for support equipment and systems required for operation. The accelerator consists of three distinct sections: the injector, SRF accelerator, and the test beam lines including space for a small storage ring. The injector is a 1.3GHz photocathode electron RF gun which generates electron bunches repeated at 3MHz within a macro pulse of nominal duration of 1ms [2, 3].

The RF power to the gun is supplied by a 5MW, 1.3GHz klystron. The temperature control loop stabilizes the temperature of the RF Gun when RF power is applied and also during no RF power cycles.

The temperature control loop regulates the water temperature to ±0.18 °C which, at a centre frequency of 1.3GHz, keeps the frequency shift of the Gun, within 5KHz (23KHz/ °C). A 5KHz shift corresponds to a reflected power less than -22dB.

SYSTEM DESCRIPTION

The task of the cooling system is to mix the outgoing warm water with the supply LCW water regulating the

* This work was supported by the U.S. Department of Energy under contract No. DE-AC02-07CH11359

[#]stabile@fnal.gov

desired temperature of the circulating water. Figure 1 shows the piping schematic of the RF gun cooling system. The cooling skid is located outside the radiation shielding and water is pumped through approximately 80 feet of piping. A PLC is integrated into the cooling skid to read back the temperature and flow measured by the different sensors and to control the flow rate of the LCW. The temperature of the LCW supply is stabilized to 90±1°F (~32.22 ±0.5°C) by an external control system running on an independent PLC. The amount of the incoming supply LCW is controlled by a fine pneumatic valve that allows a flow rate between 0 and 15GPM. The position of the valve is controlled by a dedicated PID loop build into the valve controller.

A heater is used to mix the LCW cold water and the warm water from the RF Gun and can supply between 0 and 12KW of power. The mixed water flows to the gun at a fixed rate of 15 GPM through nine cooling channels, seven with 10mm ID and two with 6mm ID tubing connections, cooling down the cavity. The return water from the gun is split between the heater and a return connection to the main chiller system.

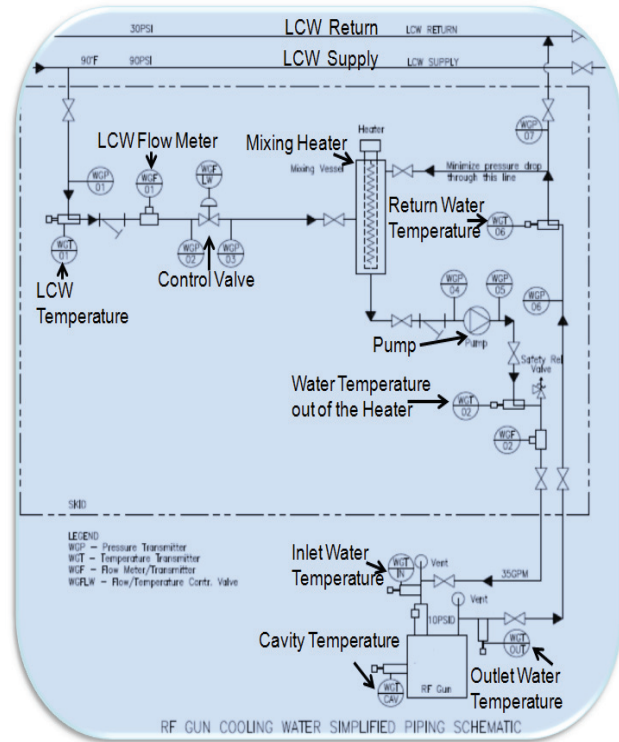

Figure 1: RF gun cooling system overview.

SYSTEM MODELING

An appropriate model of the system was first made. The RF Gun cooling can be divided into a combination of two subsystems:

- Heater
- RF Gun

Heater

The heater has a fixed volume tank completely filled with almost 1.5 gallons of water. The LCW (m_1) is mixed with the return water from the gun (m_3). The output water (m_2) from the heater flows at constant rate to the gun and removes the necessary amount heat from the cavity.

The water temperature from the heater to the Gun has to be stable; avoiding fluctuations in temperature reduces power reflections from the gun.

The heater can be modeled as a mixing tank with two inputs and one output. The differential equations describing it are:

$$M_{\sigma} \frac{dT_{02}}{dt} c_p + m_3 T_{02} c_p = m_1 T_{01} c_p + m_2 T_{06} c_p + HPWR, \quad (1)$$

$$\frac{dV}{dt} = m_1 + m_2 - m_3, \quad (2)$$

where:

- M_{σ} = volume of water of the heater (US GALLONS)
- m_1 = LCW water flow rate (GPM)
- m_2 = Return flow rate from the gun (GPM)
- m_3 = Output flow rate from the heater (GPM)
- HPWR = Heater power (KW)
- c_p = Specific heat capacity of the water at constant pressure (J/g* °C)
- T_{02} = water temperature at the output of the heater (°C)
- T_{06} = return water temperature from the gun (°C)
- T_{01} = supply water temperature (°C)
- V = heater water volume (US GALLONS).

The total water flow in the Gun is constant and the time constant of the system is:

$$\tau = M_{\sigma} / m_3, \quad (3)$$

which is equal to 5.96 sec. The steady state point can be calculated using:

$$T_{02} = T_{01} \frac{m_1}{m_3} + T_{06} \frac{m_2}{m_3} + \frac{HPWR}{c_p m_3} \quad (4)$$

RF Gun

A cavity constructed of a single metal has as percent change in wavelength equals the percent change in linear

dimension which is proportional to temperature. Frequency de-tuning of the cavity caused by expansion and deformation of the copper causes an increase of the reflected power and RF phase instability. If the frequency deviates from the drive frequency, the power reflected from the cavity will cause standing waves within the waveguide.

The thermal expansion of the copper is about 17.68ppm/°C (1ppm/°C more from the one expected) resulting in a 23KHz frequency shift per degree Celsius.

As a first approximation the cavity can be considered as a tank with water flowing through it that maintains a constant volume [4]. Assuming that the inlet water instantaneously and completely mixes into the volume, the thermal mass C will be at the outlet temperature T_{OUT} . The change in outlet temperature will be equal to the net power flowing into the volume divided by its thermal capacitance.

The following differential equation describes the system:

$$\frac{dT_{out}}{dt} = \frac{P_{rf}}{C} + \frac{F}{AC} (T_{in} - T_{out}) \quad (5)$$

The time constant is:

$$\tau = F / AC, \quad (6)$$

which depends on the set flow rate of the chilled water. The steady state point can be calculated:

$$T_{out} = \frac{AP_{rf}}{F} + T_{in}, \quad (7)$$

where:

- P_{rf} = Average RF power injected to the gun (KW)
- F = Flow rate of the chilled water (GPM)
- C = Heat capacity of the water (KJ/ °C)
- A = Heat factor (°C*GPM/KW)

IMPLEMENTATION

A combined feedforward/feedback control system has been implemented to improve performance over a simple feedback control (Figure 2).

When a step in the RF power or in the temperature set-point occurs, the feedforward algorithm calculates and sets the new LCW flow rate as a function of temperature variation of the cavity per unit of flow (°C/GPM) and per unit of power (°C/KW). The algorithm uses the initial conditions of the system (T_{CAV} , T_{SET} , T_{LCW} , T_{IN} , RF_{Power}) and the final steady state point calculates the new flow set-point. The controller take into consideration the effects of pure time delay due to pipe lengths and also the changes taking place in the return water flow temperature.

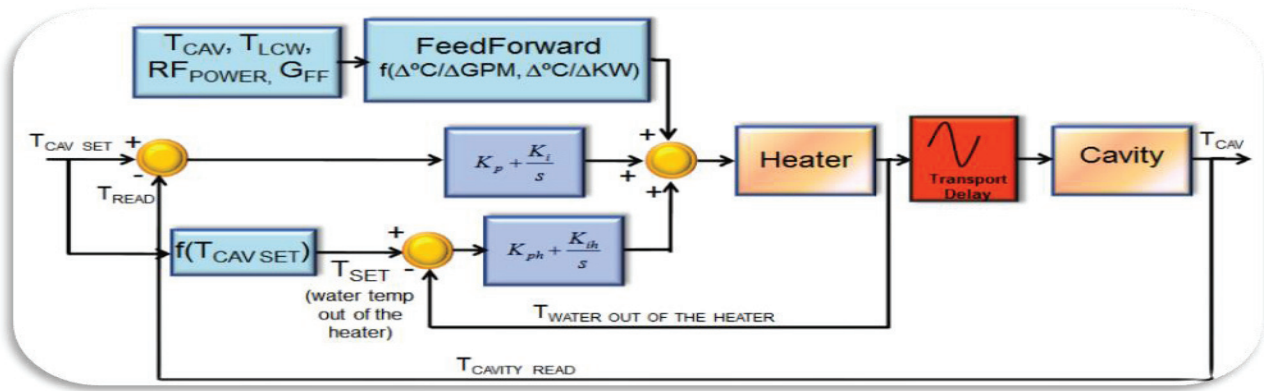

Figure 2: Feedforward/feedback block diagram.

The chilled water takes almost 40 sec. to reach the cavity enclosure, then an additional 20 sec. is required to reach the cavity.

The feedforward is an open loop response, therefore the controller needs to observe the effect of the feedforward loop on the gun temperature before closing the loop with the feedback loop. Once the steady state has been reached within ± 0.24 °C, the feedback suppresses the steady state error.

The cavity feedback was implemented as a proportional and an integral controller with a closed loop bandwidth of $\omega_{CL} = K_p(T_{in} - T_{out})/AC \sim 0.005\text{Hz}$. This makes the feedforward critical for improving the bandwidth of the controller. A conservative design has 45° phase margin.

The K_i/K_p gain ratios in the cavity feedback loop were chosen in order to minimize the overshoot of the system and meet the target phase margin. The water travel time is a “pure delay” that adds 100° to the total phase shift and can be overcome by the feedforward.

An inner feedback control loop has been added to the controller to stabilize the water temperature coming from the heater and it is still in the first stages of development.

This inner feedback loop doesn’t have the pipe transport delay therefore its bandwidth is higher than the cavity loop.

RESULTS

The RF Gun is in final stages of conditioning and first electron beam has been produced.

Figure 3 shows the temperature control obtained with a constant power applied to the RF Gun. The temperature set-point is 42.1°C and the peak RF Power is 1.7MW with a pulse rate of 1Hz and a pulse width of 800µsec. The orange trace is the cavity temperature. The data collected shows that the cavity temperature can be stabilized in a range of 42.1 ± 0.18 °C.

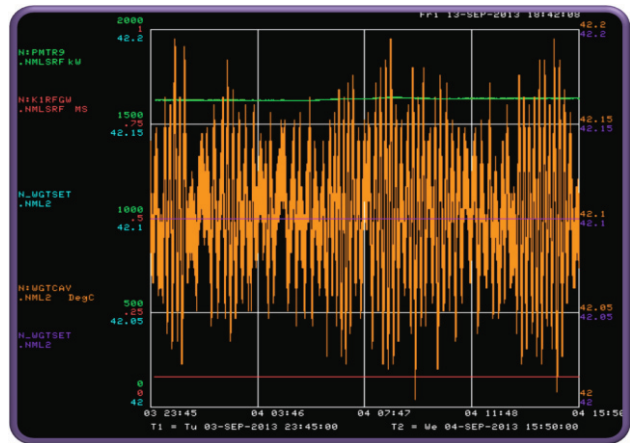

Figure 3: Cavity Temperature control with no RF power.

ACKNOWLEDGMENT

Authors would like to acknowledge all the ASTA project team for their support to this work.

REFERENCES

- [1] J. Leibfritz et al., “Status and plans for a superconducting RF accelerator test facility at Fermilab,” IPAC2012, New Orleans, Louisiana, MOOAC02, p. 58 (2012); <http://www.JACoW.org>
- [2] M Church and S. Nagaitsev, “Plans for a 750MeV Electron Beam Test Facility at Fermilab,” PAC’07, Albuquerque, New Mexico, THPMN098, p. 2939 (2007); <http://www.JACoW.org>
- [3] M. Church et al., “Plans for a 750 MeV Electron Beam Test Facility at Fermilab,” PAC’07, Albuquerque, New Mexico, THPMN099, p. 2942, (2007).
- [4] J. Crisp and J. Satti, “Fermilab Linac Upgrade Side Coupled Cavity Temperature Control System”; <http://beamdocs.fnal.gov/AD/DocDB/0035/003506/001/LinacUpgradeTempCntlSys-Crisp.pdf>