

MECHANICAL ANALYSIS OF THE 400 MHz RF-DIPOLE CRABBING CAVITY PROTOTYPE FOR LHC HIGH LUMINOSITY UPGRADE*

S. U. De Silva^{1,2#}, H. Park^{2,1}, J. R. Delayen^{1,2}, Z. Li³

¹Center for Accelerator Science, Old Dominion University, Norfolk, VA 23529, USA

²Thomas Jefferson National Accelerator Facility, Newport News, VA 23606, USA

³SLAC National Accelerator Facility, Menlo Park, CA 94025, USA

Abstract

The proposed LHC high luminosity upgrade requires two crabbing systems in increasing the peak luminosity, operating both vertically and horizontally at two interaction points of IP₁ and IP₅. The required system has tight dimensional constraints and needs to achieve higher operational gradients. A proof-of-principle 400 MHz crabbing cavity design has been successfully tested and has proven to be an ideal candidate for the crabbing system. The cylindrical proof-of-principle rf-dipole design has been adapted in to a square shaped design to further meet the dimensional requirements. The new rf-dipole design has been optimized in meeting the requirements in rf-properties, higher order mode damping, and multipole components. A crabbing system in a cryomodule is expected to be tested on the SPS beam line prior to the test at LHC. The new prototype is required to achieve the mechanical and thermal specifications of the SPS test followed by the test at LHC. This paper discusses the detailed mechanical and thermal analysis in minimizing Lorentz force detuning and sensitivity to liquid He pressure fluctuations.

INTRODUCTION

The rf-dipole design is a favorable design for compact deflecting and crabbing applications especially at low operating frequencies [1]. The LHC high luminosity upgrade is one such current application that requires a crabbing cavity system with stringent dimensional constraints that will be operating at 400 MHz [2].

The rf-dipole cavity is one of proposed crabbing cavity designs. The design is proven to have improved rf-properties with low and balanced peak surface fields with high transverse deflection and high shunt impedance. The non-existence of lower order modes and widely separated higher order mode spectrum is an added advantage for this high current application of LHC.

An rf-dipole cavity with a cylindrical outer conductor has been designed and fabricated as a proof-of-principle cavity. The rf tests have been carried successfully [3]. The expected goal of 3.4 MV was exceeded and a transverse voltage of 7.0 MV was achieved. The major unknown in the rf-dipole geometry was the expected multipacting levels during operation. The conditions were simulated

using the SLAC ACE3P code [4] and compared with rf results, show similar behavior. These multipacting levels were easily processed during the first cryogenic rf test and did not reoccur during the tests followed.

400 MHz CRABBING CAVITY PROTOTYPE

The transverse dimensions of the proof-of-principle cavity design exceed the dimensional specifications required by the LHC crabbing system. The cylindrical outer conductor restricts in reducing the cavity size as the operating frequency is directly related to the cavity frequency. The rf geometry is modified into a square shape outer conductor with similar loading elements, where the operating frequency is adjusted by rounding the edges of the cavity (Fig. 1) [5]. The rf properties of the prototype in comparison with the cylindrical cavity are shown in Table 1.

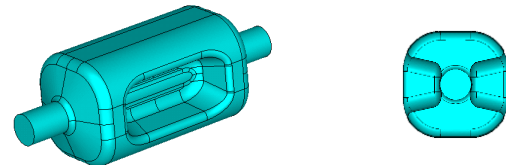

Figure 1: 400 MHz rf-dipole prototype with trapezoidal-shaped loading elements and the cross section.

Table 1: Properties of the Proof-of-principle and Prototype 400 MHz Rf-dipole Cavities

Parameter	Cylindrical shaped	Square shaped	Units
Cavity length	542.4	556.2	mm
Cavity diameter	339.9	281.0	mm
Aperture diameter (d)	84.0	84.0	mm
Bars length	350.3	293.0	mm
Bars inner height	80.0	117.5	mm
Angle	50.0	~12.0	deg
Deflecting voltage (V_T^*)	0.375	0.375	MV
Peak electric field (E_p^*)	4.02	3.65	MV/m
Peak magnetic field (B_p^*)	7.06	6.13	mT
B_p^* / E_p^*	1.76	1.68	
Energy content (U^*)	0.195	0.13	J
Geometrical factor	140.9	106.2	Ω
$[R/Q]_T$	287.0	429.2	Ω
$R_T R_S$	4.0×10^4	4.6×10^4	Ω^2

At $E_T^* = 1$ MV/m

The inner loading elements are curved to suppress the field non-uniformity across the beam aperture and to reduce the corresponding multipole components.

*Authored by Jefferson Science Associates, LLC under U.S. DOE Contract No. DE-AC05-06OR23177. The U.S. Government retains a non-exclusive, paid-up, irrevocable, world-wide license to publish or reproduce this manuscript for U.S. Government purposes.

#sdesilva@jlab.org

The complete cavity with fundamental power coupler and HOM couplers are shown in Fig. 2. The HOM couplers have been designed to achieve the transverse and longitudinal damping thresholds [5].

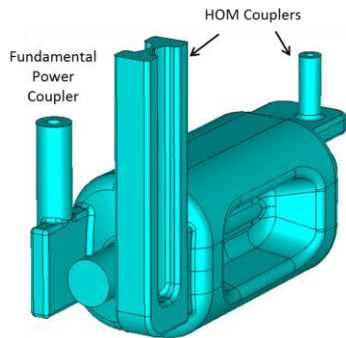

Figure 2: 400 MHz crabbing cavity proposed for LHC high luminosity upgrade.

The rf-dipole prototype design is finalized in terms of electromagnetic properties. The simulated multipacting conditions using the Tack3P in SLAC ACE3P suite [4] shows improved levels compared to the cylindrical proof-of-principle design [5].

MECHANICAL ANALYSIS

The 400 MHz crabbing cavity proposed for the LHC luminosity upgrade is expected to be tested at the SPS beam line prior to the tests at LHC. The SPS tests will include 1 or 2 cavities in a single cryomodule. Current work is focused in fabricating and testing of the first prototype, followed by the cryomodule assembly and testing at the SM18 test cryostat at CERN. The cavity will be beam tested at SPS beam line [2]. Prior to the cryostat assembly the cavity will be tested in a vertical test stand, preferably at the Jefferson Lab vertical test facility.

Stress Analysis

The rf cavity is expected to withstand different load conditions under different external pressures related to operational and safety conditions during vertical rf testing [6], cryomodule testing and beam line testing [7] as listed below:

- ❖ RF testing at the vertical test facility at Jefferson Lab
 - Testing condition – 1 atm external pressure at room temperature and during leak check
 - Operating condition – 1.1 atm external pressure and tuning force at 4 K. At 2 K the external pressure decreases to 0.03 atm
 - Safety condition – 1.4 atm external pressure at room temperature
- ❖ Cryomodule testing at the SM18 test cryostat at CERN
 - Maximum allowable pressure – 1.5 atm
 - Safety test pressure – 2.1 atm at room temperature
- ❖ Cryomodule testing in SPS at CERN
 - Maximum allowable pressure – 1.8 atm
 - Safety test pressure – 2.6 atm at room temperature

The rf dipole cavity fabricated with Nb sheets will experience stress levels under the different operating

conditions. The estimated stress levels are required to be below the yield strength for Nb with material properties shown in Table 2.

Table 2: Material Properties of Nb at Room Temperature (RT) and Cryogenic Temperature of 4 K Used at CERN

Parameter	Value	Units
Density	8600	kg/m ³
Poisson's ratio	0.4	
Young's modulus at RT	1.0×10 ¹¹	Pa
Young's modulus at 4 K	1.23×10 ¹¹	Pa
Yield strength at RT	75	MPa
Max allowable stress at RT	70	MPa

The stresses analyzed using ANSYS [8] shows that the edges of the loading elements experience the highest stresses due to external pressure (Fig. 3), hence requires additional reinforcement to reduce the stresses below the yield strength.

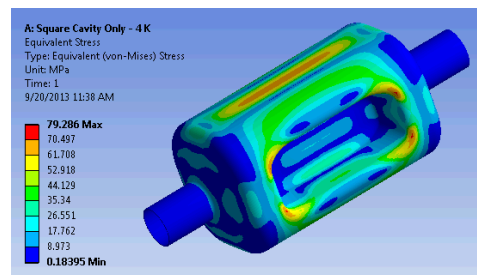

Figure 3: Stress distribution at 4 K and external pressure of 1 atm for a cavity with 3 mm uniform thickness.

Several options of cavity thicknesses with additional reinforcement were studied to achieve the design specifications for different operating conditions. Cavity with a uniform 3 mm thickness with stiffening plates added at the edges of the loading elements or a cavity with uniform thickness of 4 mm results similar stresses. The obtained stresses are below the yield strength for test conditions in a vertical test assembly, however does not meet the safety specifications for cryostat operation.

The cavity with uniform thickness of 4 mm is considered with additional 4 mm stiffening plates shown in Fig. 4, meets the operational and safety requirements for testing in a vertical test assembly as well as in a cryostat test.

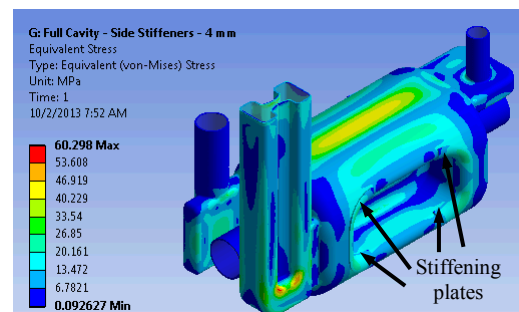

Figure 4: Stress distribution at 4 K and external pressure of 1.1 atm.

As shown in Fig. 5 at an external pressure of 2.1 atm the cavity body has a stress intensity below 70 MPa,

which meets the specifications under cryostat operation. The higher stresses shown at the horizontal HOM coupler can be reduced with the fixed support by the addition of flange and helium tank mount.

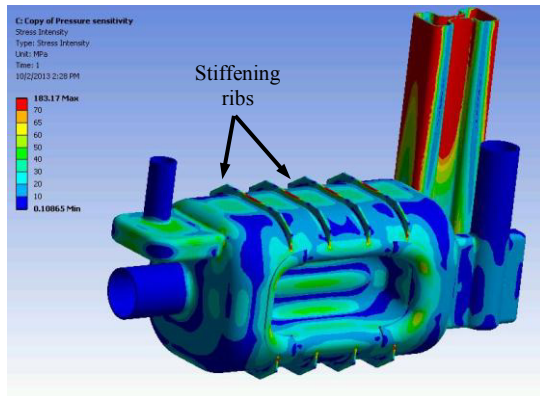

Figure 5: Stress intensity due to external pressure of 2.1 atm at room temperature.

Pressure Sensitivity

The flat surfaces at the top and bottom of the cavity experience the highest deformation due to external pressure. Table 3 shows the pressure sensitivity of the different cavity design options. The cavity with a 4 mm uniform thickness and stiffening ribs improved the sensitivity to pressure with a reduced ratio of -18.5 Hz/torr.

Table 3: Pressure Sensitivity for Different Cavity Designs

Cavity Design	df/dP [Hz/torr]
Cavity with no coupler ports of 3 mm uniform thickness	-368.2
Cavity with coupler ports of:	
3 mm uniform thickness	-369.6
4 mm uniform thickness	-170.8
4 mm uniform thickness and stiffeners	-18.5

Lorentz Detuning

The Lorentz force detuning is an effect where the cavity is deformed by the radiation pressure. The magnetic field applies pressure and deforms the surface outward, while deformation due to electric field is inward as shown in Fig. 6. The curved loading elements around the beam aperture region reduce the deformation due to electric field while the outward deformation due to magnetic field counteracts the deformation due to external pressure to some extent.

The Lorentz coefficients (k_L) for different cavity designs:

- with 3 mm uniform thickness = -162.9 Hz/(MV/m)²
- with 4 mm uniform thickness = -113.7 Hz/(MV/m)²
- with 4 mm uniform thickness and stiffeners = -84.5 Hz/(MV/m)²

The stiffeners were placed on the cavity to reduce the stresses for vertical testing, cryostat operation and safety

conditions. The Lorentz coefficients can be improved with further reinforcement.

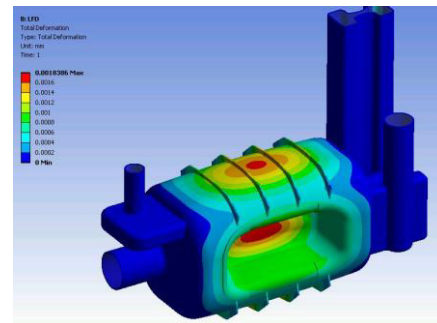

Figure 6: Deformation due to Lorentz force detuning.

CONCLUSION

The 400 MHz proof-of-principle cavity rf tests achieved a transverse voltage of 7.0 MV with high peak surface fields that gives the possibility of operating at a transverse voltage of 5.0 MV, which is above the expected goal of 3.4 MV. The preliminary mechanical analysis for the rf-dipole prototype cavity has been completed. Further analysis will be continued on reducing the pressure sensitivity and Lorentz detuning.

ACKNOWLEDGEMENTS

This work was partially supported by the U.S. DOE through the US LHC Accelerator Research Program (LARP), by the EU FP7 HiLumi LHC Grant Agreement 284404, and by the U.S. DOE HEP SBIR/STTR program through Niowave Inc., Lansing, MI.

We also would like to thank Gary G. Cheng for the support with ANSYS simulation.

REFERENCES

- [1] S. U. De Silva and J. R. Delayen, Phys. Rev. ST Accel. Beams 16, 012004 (2013).
- [2] P. Baudrenghien, et al., Functional Specifications of the LHC Prototype Crab Cavity System, Tech. Rep. CERN-ACC-NOTE-2013-003 (CERN, 2013).
- [3] S. U. De Silva and J. R. Delayen, Phys. Rev. ST Accel. Beams 16, 082001 (2013).
- [4] K. Ko, et al., in Proceedings of the 25th Linear Accelerator Conference, Tsukuba, Japan (2010), p. 1028.
- [5] Z. Li, L. Ge, J. R. Delayen, and S. U. De Silva, in Proceedings of the 4th International Particle Accelerator Conference, Shanghai, China (2013), p. 2468.
- [6] H. Park, J. R. Delayen and S. U. De Silva, in Proceedings of 15th Conference on RF Superconductivity, Chicago, Illinois (2011), p. 188.
- [7] L. Alberty, "Prototype Cavity Stress Analysis", LHC Crab Cavity Engineering Meeting, FNAL, December, 2013.
- [8] "ANSYS Academic Research, Release 13.0, Structural Mechanics Analysis, ANSYS, Inc.", (2010), <http://www.ansys.com>.