

DESIGN OF A SUPERCONDUCTING HALF WAVE RESONATOR MODULE FOR PROTON/DEUTERON ACCELERATION

M. Pekeler, K. Dunkel, R. Henneborn, C. Piel, M. Poier, P. vom Stein, H. Vogel
ACCEL Instruments GmbH, 51429 Bergisch Gladbach, Germany

Abstract

Within the contract of the supply of a turn key proton/deuteron LINAC for SOREQ, a superconducting half wave resonator RF module was designed for the acceleration of protons/deuterons from about 1.5 MeV/u to about 6.5 MeV. The module consists out of 6 superconducting half wave resonators designed for optimum acceleration of protons/deuterons with velocity $0.09 c$, 3 superconducting solenoids for focussing, cavity tuners and couplers, thermal shield, magnetic shielding, vacuum vessel, helium vessels, helium supply/return and all instrumentation. Main design considerations of the cavities, solenoids, tuners and couplers as well as for the module especially in view of assembly and alignment will be explained. A major design challenge was the need from beam dynamics to minimize the longitudinal distance between the cavities. Prototype tests of cavity, helium vessel, tuner and coupler all at cryogenic temperatures are foreseen before the main production is launched. A cavity preparation and cold RF test facility for cavities and completed modules is under construction at ACCEL to allow first cold RF tests at the beginning of next year.

MODULE DESIGN

An overview drawing of the prototype superconducting half wave resonator module is given in Figure 1.

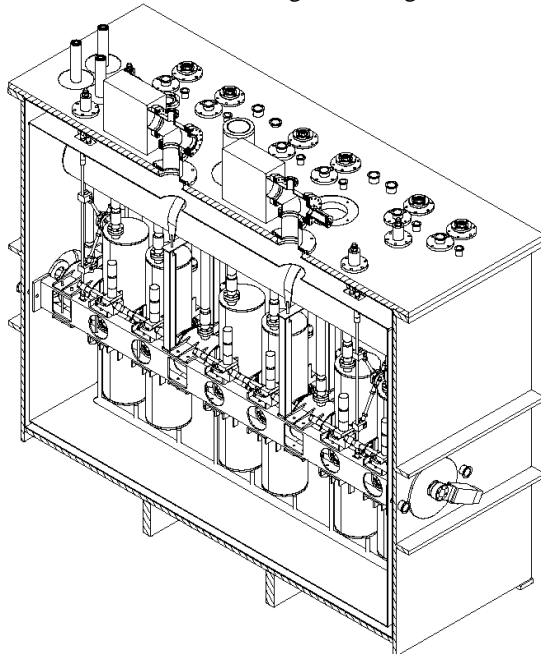

Figure 1: Overview drawing of the prototype superconducting half wave resonator module.

The design of the cryostat is driven by the need of compactness and easy assembly. Beam dynamics require a very tight installation in longitudinal direction. All equipment will be attached to the top plate. This facilitates the assembly in and outside the clean room. All ports and interfaces are located on the top plate of the cryostat.

The cryostat is a rectangular box with dismountable top plate. The cavity vacuum and the insulation vacuum is separated to ensure cleanliness and avoid contamination of the cavities. The module consists out of:

- Vacuum vessel out of 304 stainless steel.
- Magnetic shield to protect the cavities from stray earth magnetic field.
- Thermal shield out of copper, cooled to 70 K by cold helium gas.
- 6 superconducting 176 MHz half wave resonators out of bulk niobium RRR 250.
- 3 superconducting solenoids for focussing designed for 6 T operating field
- Individual helium vessel for cavities and solenoids, helium storage tank on top of cavities and solenoids, helium piping system all manufactured out of 316 LN stainless steel.
- Mechanical reference frame out of 316 LN stainless steel to which all cavities and solenoids are attached and aligned.
- Tuners for each cavity.
- Coaxial couplers for each cavity.
- Module instrumentation like helium level sensors, cryogenic temperature sensors, heaters, RF probes and vacuum gauges and pumps.

CAVITIES

The shape of the half wave resonators produced out of RRR 250 niobium is shown in Figure 2.

Each cavity has 4 ports located on beam axis; two are beam ports, one RF coupler port and one pumping port with integrated pick-up probe. The design parameters of the cavity and specifications are listed in Table 1. The design gradient of the cavities is 2.5 MV/m peak electric surface field at an unloaded quality factor of 5×10^8 .

A prototype cavity is currently under production. The preparation for vertical test includes buffered chemical polishing in closed loop chemistry with temperature control of the acid, high-pressure water rinsing and clean room assembly. The complete preparation and the cold cavity RF test will be performed at ACCEL.

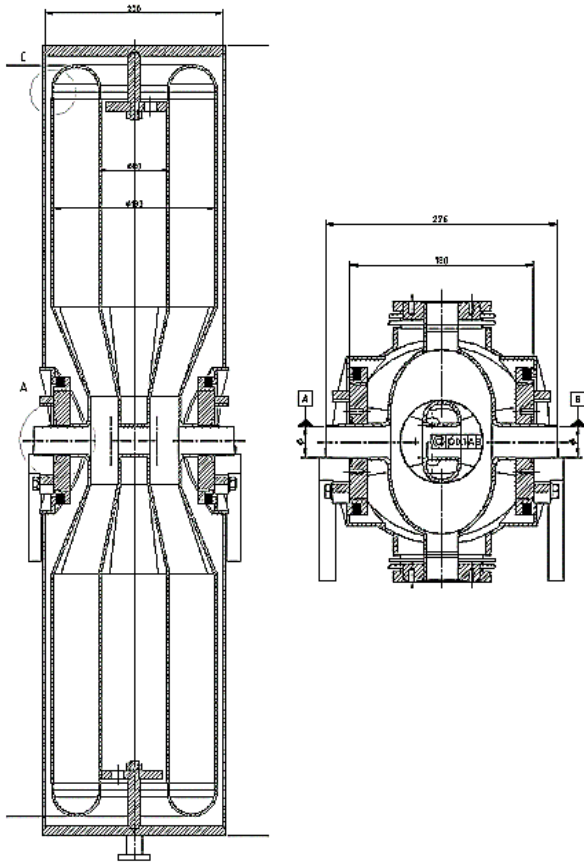

Figure 2: Side view and cut through beam height of the half wave resonator.

Table 1: Geometrical Parameters and target values of the half wave resonator

Parameter	Value	Unit
Frequency	176	MHz
Cavity height	835	mm
Diameter of inner conductor	80	mm
Diameter of outer conductor	180	mm
Wall thickness	3	mm
Cavity volume	17	l
Accelerating length L_{acc}	99	mm
Optimum β	9	%
Geom. constant $G = R_S \times Q_0$	24.5	Ω
Shunt Impedance R/G	164	Ω
E_{peak} / E_{acc}	2.9	
B_{peak} / E_{peak}	2.1	mT/MV/m
B_{peak} / E_{acc}	6.2	mT/MV/m
U_{acc}	0.845	MV

Parameter	Value	Unit
E_{peak}	25	MV/m
E_{acc}	8.58	MV/m
B_{peak}	80	mT
Q_0 (4.4 K, low field)	1.1×10^9	
P_{BCS} (Res = 10 nW), $E_{peak} = 25$ MV/m	4.3	W
Goal P_{diss} , $E_{peak} = 25$ MV/m	< 10	W
Goal Q_0	$> 4.7 \times 10^8$	

COUPLER

A view of the coupler is shown in Figure 3. The coupler consists out of 2 coaxial RF windows with instrumentation ports. One window will be mounted directly to the cavity and cooled to 70 K. The other window is at room temperature and located at the top of the cryostat. The volume between the two windows is pumped through slits in the inner conductor by the insulation vacuum. For the foreseen beam current of up to 4 mA, an external Q of 1.3×10^6 is needed. The power through each coupler is 4 kW at maximum cavity field and beam current.

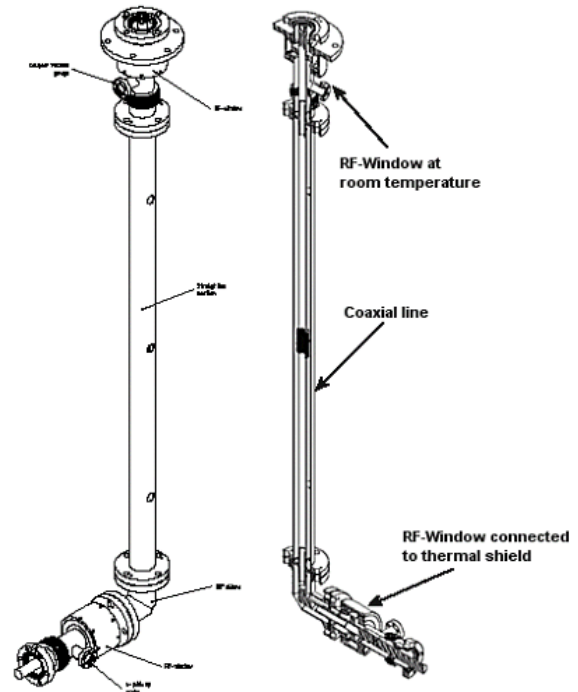

Figure 3: Drawing of capacitive coupler foreseen in the superconducting half wave resonator module.

Table 2: Technical specification of the coupler

Item / Parameter	Value / description
External Q	1.3×10^6
Transmitted power	< 4 kW
Coaxial lines	Standard 1 5/8", approximately 1 m long Inner conductor copper pipe, outer conductor stainless steel, 10 μ m copper plated
Gradient of electric field strength at 4kW	136.8 kV/m
RF Losses inside the cryostat at 4 kW	ca 8 W, 6 W at 70K, 0.3W at 4.3 K

TUNER

At an external Q of the cavity of 1.3×10^6 , the bandwidth of the cavity is about 130 Hz. A tuning accuracy of 1 Hz is therefore desired. A drawing of the tuner is shown in Figure 4.

The tuner consists out of a cold stepper motor with lever mechanism for coarse tuning and a piezo element for fine-tuning. There are two stepper motors and piezo elements foreseen, mounted one on each side of the cavity in order to reduce the forces on the piezo element.

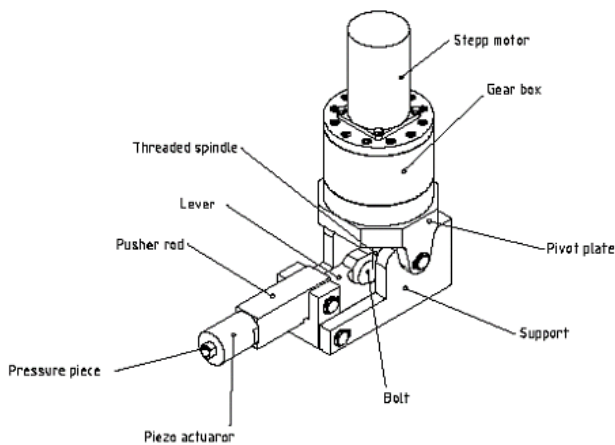

Figure 4: Drawing of tuner foreseen in the superconducting half wave resonator module.

Table 3: Technical specification of the tuner

Item / Parameter	Value / description
Type	Tesla / SNS-type
Actuator	Lever Mechanism, Cold motor, Harmonic-drive Gear, fine tuning with piezo element

Item / Parameter	Value / description
Tuning way	1 mm
Sensitivity	150 Hz/mm
bandwidth	135 Hz

SOLENOIDS

The solenoids are designed to operate at maximum 6 T field. A drawing of the solenoid is shown in Figure 5.

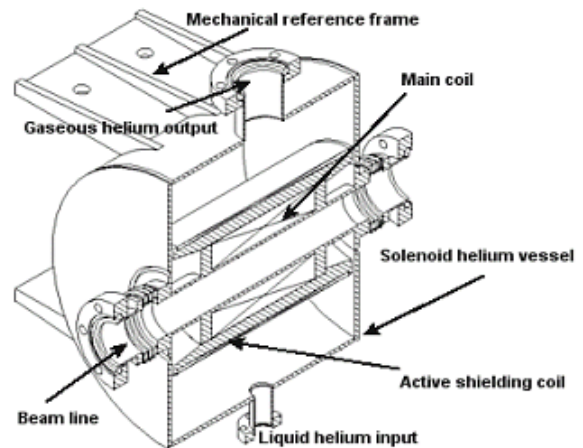

Figure 5: Drawing of solenoid foreseen in the superconducting halfwave resonator module.

The solenoid consists of a main coil and an active shielding coil in order to minimize the stray fields of the solenoids at the cavity location. A test is foreseen with the completed superconducting cavity in its final position relative to the solenoid to determine the allowable external magnetic field at the cavity location allowing the cavity to stay in the superconducting state. It is also important to design the solenoids to achieve very low remanence field. In any case, the solenoids are only allowed to be switched on after the cavities have reached the superconducting state.

Table 4: Technical specification of the solenoids

Item / Parameter	Value / description
Diameter of main coil	35 mm
Beam Pipe diameter	30 mm
Operational current	116 A
Magnetic field	6 T
Acceleration time	23 s
Maximum magnetic field at a distance of 0,1 m from solenoid center	0,1 T
Remanence field at a distance of 0,1 m from solenoid center	Goal < 2 μ T
Superconducting wire	NbTi, 0.60 mm,

CRYOGENIC SPECIFICATION

The cryogenic specification of the superconducting module is summarized in Table 5. As the cavities are very sensitive to helium bath pressure variations, the helium bath needs to be stabilized to +/- 1.5 mbar. The thermal mass of the module was calculated to be 80 MJ. The cool-down and warm-up of the module is limited to a gradient of 30 K/hour in order to minimize the introduced stresses.

Table 5: Cryogenic specification of the superconducting halfwave resonator module

Source	Losses at 80 K	Losses at 4 K
Static losses		
Radiation losses	29 W	1.3 W
Losses from thermal conduction	50 W	7.6 W
Sum Static losses	79 W	8.9 W
Dynamic losses		
6 cavities	-	6 x 10 W = 60W
6 input couplers	6 x 6 W = 36 W	6 x 0.3 W = 1.8 W
current leads of solenoids	-	0.4 W
Sum dynamic losses	36 W	62.2 W
Total losses (static + dynamic)	115 W	71.1 W

PROTOTYPE PROGRAM

For the cavities, tuners, couplers and solenoids prototypes will be built before the production is launched.

Important goals of this program are to demonstrate the desired gradients and quality factors of the cavities, to measure the allowable external magnetic field after the cavity reached the superconducting state (important for solenoid design) and to determine the remanenz field of the solenoids. The coupler performance needs to be demonstrated in view of transmitted power and the tuner will be tested under operating conditions (cold and in vacuum) in a vertical bath cryostat attached to a real cavity completed with helium vessel.

This prototype program is launched and first results are expected for the beginning of 2004.