

NEW CAVITY SHAPE DEVELOPMENTS FOR CRABBING APPLICATIONS

G. Burt, Cockcroft Institute, Lancaster University, UK

Abstract

Deflecting mode cavities are required in several accelerators for use as crab cavities in colliders and light sources and as separators. The space requirements for these applications are extremely tight due to two or more beamlines being close together. In addition the dipole mode cavities have lower and same order modes as well as higher order modes which require damping to very low Q values. A number of designs are proposed for compact and/or strongly damped SRF crab cavities. This paper will discuss various coaxial type crab cavities which allow the design of compact crab cavities operating at frequencies below 500 MHz. In addition a number of novel damping schemes will be shown and evaluation of these designs including multipacting will be discussed.

INTRODUCTION TO CRAB CAVITIES

Crab cavities are a subset of transverse deflecting cavities, where the bunch traverses the cavity at the zero kick phase. Due to the finite size of the bunch only the centre does not receive a kick, the head and tail of the bunch receive equal and opposite kicks [1].

As we wish to kick the beam transversely and not accelerate it we utilise one polarisation of the fundamental dipole mode as the operating mode. This leaves the fundamental accelerating mode, known as the Lower Order Mode (LOM), as an unwanted mode which must be damped to avoid disrupting the beam. In addition as the dipole mode has two polarisations the other polarisation, known as the same order mode (SOM), can cause large deflections to the beam due to its high R/Q. As the LOM and SOM are usually at frequencies close to or lower than the frequency of the operating mode these modes are very difficult to damp.

As the crab cavities use the dipole mode for their operation, they are about 30% larger than accelerating cavities of the same frequency. This is often problematic as the cavities are usually positioned close to an interaction point where space is limited.

The first crab cavities installed in an accelerator were the KEK-B crab cavities [2]. These were a pair of single cell SRF cavities at 508.9 MHz. They used a racetrack cross-section to split the resonant frequencies of the two fundamental dipole mode polarisations. To remove the accelerating mode a hollow coaxial beam-pipe damper was utilised, shown in Figure 1. This hollow coaxial line was adjustable and was also able to be used as a cavity frequency tuner. The coax was able to avoid coupling to the crabbing mode due to symmetry however a notch filter was also used in case of misalignment.

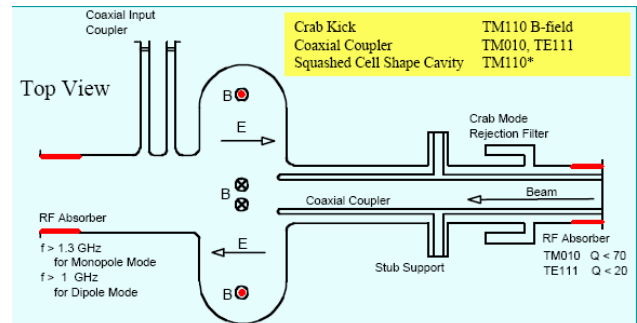

Figure 1: A schematic of the KEKB crab cavity showing the Coaxial LOM damper.

This was not the first SRF deflecting mode cavity, as CERN utilised two S-band SRF deflectors, constructed at Karlsruhe, in the 300 GeV proton synchrotron [3]. These were two 104 cell periodic $\pi/2$ mode niobium deflectors. These were the first superconducting, high frequency devices made for accelerators, designed and constructed in 1970-1977. They originally provided kaon beams for the omega spectrometer at CERN but have since been moved to IHEP.

More recently a 13-cell S-band cavity was designed as a kaon separator at FNAL. A 9-cell version of this design was modified and proposed as the crab cavity for the ILC [4]. This cavity is shown in Figure 2. This cavity was manufactured cylindrically symmetric and was squashed by up to 5 mm after e-beam welding. A hook-type LOM coupler was used and the LOM and SOM couplers were placed on the electric field null to avoid coupling to the crabbing mode. A 13 cell version of the FNAL cavity was produced and several single cell tests were performed. Aluminium models of this cavity were also produced for various cold measurements to verify the simulations.

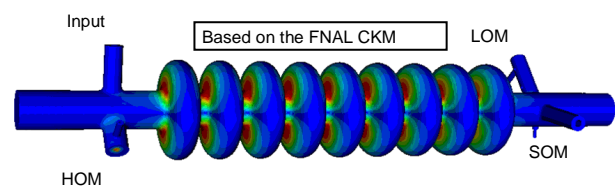

Figure 2: The 9 cell ILC crab cavity showing the various couplers. The plot shows the relative electric field magnitude of the crabbing mode simulated in Omega3P.

The new crab cavity shape developments can be split into two types, those that provide better damping of the LOM and SOM, and those that provide compact size designs. We will discuss some of the new designs for both types in this paper.

NOVEL DAMPING SCHEMES

The low frequency of the LOM, as well as its coupling to the TM₀₁ mode of the beam-pipe as opposed to the dipole mode which couples to the TE₁₁ mode, leads to the LOM being trapped inside the main cavity body and not penetrating far into the beam-pipe. This makes this mode difficult to damp, hence we require a mode selective damper that penetrates far into the beam-pipe near the cavity and that doesn't couple to the operating mode.

Like-wise, as the SOM is very similar to the operating mode, a mode selective coupler is also required [5]. This is made more complex by the similar frequencies of the two modes. The couplers can be made mode selective by either using filters (which can be difficult if the SOM frequency is close to the operating mode), or by aligning the couplers such that it couples to the SOM but is placed in the electric or magnetic node of the operating mode (depending on the coupler). Using mode selective couplers utilising coupler alignment requires the coupler to be perfectly aligned with respect to the crabbing/operating mode node. As the SOM is often damped to an external Q below 100, this can set very tight limits on coupler alignment.

On-cell Damping

Traditionally mode dampers for SRF cavities are placed on the beam-pipes to avoid unnecessary e-beam welds on the cavity body. However as the operating mode is polarised in deflecting mode cavities, there is a large section of the cavity, at 90 degrees to the mode polarisation, where no currents flow due to the operating mode. This means that if a coupler is placed there it will not couple to the operating mode or perturb that mode in any way. The LOM and SOM however have large surface currents flowing in that region and hence will couple strongly to any coupler placed in that region.



Figure 3: The proposed ANL crab cavity showing the on-cell damping waveguide.

An on-cell waveguide damping scheme, where a waveguide damper is placed on the cavity equator, is proposed for the Argonne Light Source [6] (shown in Figure 3) and an option for the LHC luminosity upgrade Phase I [7] proposed by Cockcroft, TJNAF and Tech-X (shown in Figure 4). The waveguide does not affect the operating mode and all welds and pull-outs are placed in regions of low fields and currents. However the large magnetic field from the LOM and SOM cause these modes to be damped to external Q factors lower than 100.

A prototype of cavity utilising this scheme has been developed at TJNAF, using the ALS crab cavity design. The first ANL on-cell damper structure was made directly by machining the equator's slot to match a "saddle" adapter in a 3-D contour. Three pieces were EB-welded both from the outside and inside through isises. A second adapter joining the "saddle" and waveguide was made for the sequenced EB-welds.

For the LHC upgrade the cavity is azimuthally symmetric (except for the waveguide) and is hence polarised by the waveguide damper only, hence the operating mode and the coupler are always perfectly aligned. The two-cell cavity has an on-cell damper on each cell. They are each on separate sides of the cavity so that the average offset of the mode due to the couplers is zero. The cavity also has an input coupler and a HOM coupler on the cavity beam-pipes. Both of these couplers are also waveguide couplers. This type of cavity may require bellows on the LHe vessel so that when the cavity is being tuned the on-cell dampers do not get deformed.

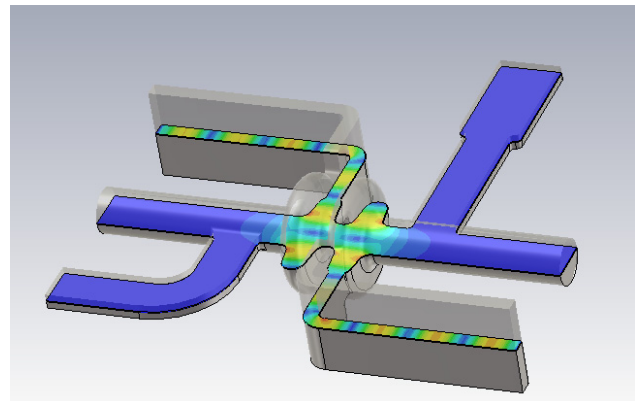

Figure 4: The UK-Jlab-TechX LHC crab cavity concept utilising on cell damping. The plot shows the relative electric field magnitude of the SOM. Simulated in CST-Microwave Studio.

There is also another on-cell damping scheme proposed for the LHC upgrade Phase I by KEK that utilises coaxial dampers located on the cavity wall that penetrate into the cavity originally designed for SuperKEKB [8], shown in Figure 5. In this scheme the coaxial dampers are placed along the electric node of the crabbing/operating mode where there are no surface currents. For strong coupling to the LOM the inner conductor stretches to the other wall of the cavity. The cut-off frequency of the TE₁₁ mode in the coaxial line is made higher than the crabbing mode and in addition a notch filter is added to avoid coupling to the crabbing mode. This damping scheme has an external Q for the LOM of 25. This scheme also uses cross shaped waveguide dampers to damp the SOM and higher order modes (HOMs). Although these couplers are placed in the same polarisation of the crabbing mode they are placed at locations where they do not cut the surface currents hence avoiding coupling to or perturbing the crabbing mode.

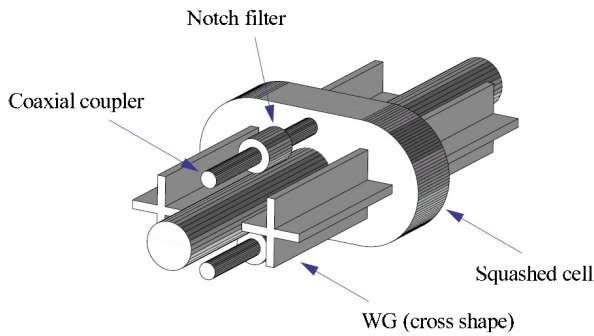

Figure 5: The KEK LHC crab cavity concept.

Coax-Coax Beam-pipe Damping

The KEK-B crab cavity used a long hollow coaxial beam-pipe to extract the LOM from the cavity to an external load. This scheme while effect was very difficult to implement and accurately align. In order to reduce the alignment problems it is proposed to e-beam weld the hollow coaxial inner conductor to the beam-pipe close to the cavity in order to shorten the coax length. In order to remove the power from the hollow inner conductor a 2nd coaxial line is capacitively coupled to the inner conductor at a right angle, shown in figure 6. As this 2nd coaxial line is at 90 degrees to the beam-pipe it can be aligned such that it will couple to the LOM and SOM but not the operating mode, as the tip of the coupler is placed at the electric node. This also allows the LOM and SOM to be damped to external Q's below 100. Connecting the coax to the beam-pipe, however, poses several manufacturing and processing questions that require further study.

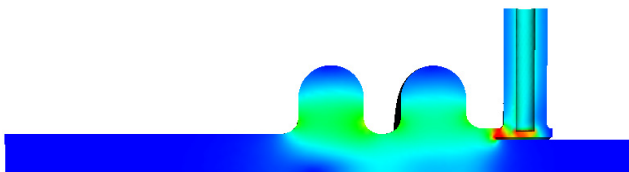

Figure 6: The SLAC coax-coax damping scheme proposed for LHC. The plot shows the relative electric field magnitude for the SOM simulated in Omega-3P.

Such a scheme is proposed as one of the options for the LHC luminosity upgrade Phase I [9]. In this design the cavity has a racetrack cross-section and hence the coupler needs to be accurately aligned to the cavity polarisation.

A variant of this cavity scheme also is able to damp the other mode in the crabbing passband. This is often a major problem in crab cavities as the passband of crab cavities is often very narrowband and the phase stability requirements are tight. In this scheme a very long beam-pipe, half wavelength long, is used to separate the two cells. This means the cavity operates in the 0 mode as opposed to the pi mode. The large separation allows the use of a standard coaxial coupler to be placed into the iris. As the fields of the o and pi modes are very different in

this region we can preferentially couple to the unwanted mode.

MULTIFACTOR

In accelerating cavities, experience has lead to the elliptical shape which suppresses multipactor. However for deflecting cavities the multipacting trajectories are very different and these shapes do not suppress multipactor in dipole modes.

All of the 800 MHz elliptical cavities proposed for the LHC luminosity upgrade have shown signs of multipactor in simulations, including CST-Particle Studio, VORPAL and Track-3P [10]. In all cases this is a two point low order multipactor on either side of the electric node azimuthally on the central iris where the electric field is weak, shown in Figure 7. In this region we have the maximum magnetic field which causes the electrons to loop back and forth in a semi-circle around the electric node. A similar type of multipactor was found in the KEK-B 509 MHz cavities [11]. This is similar to the multipactor often found in Quarter wave resonators at the peak magnetic field.

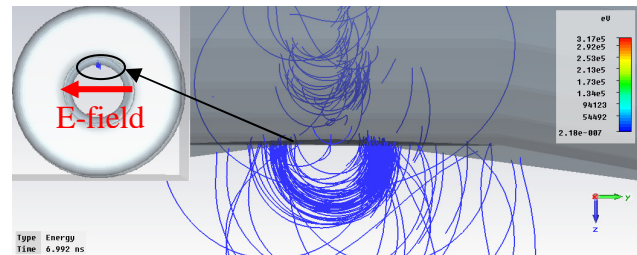

Figure 7: Multipacting trajectories in the LHC crab cavity, modelled in CST- Particle Studio.

Simulations using CST-Particle Studio have shown that the voltage at which this multipactor band occurs is determined by the peak magnetic field in the iris. Multipacting is found to always occur at the same peak magnetic field value and is related to the cyclotron resonant frequency of the electrons. Simulations in CST-Particle Studio have shown that in order to avoid multipactor is necessary to minimise the ratio of peak magnetic field to transverse kick. This can be achieved by using a small iris radius or by optimising the cavity shape in the iris region.

In the high frequency cavities such as the ILC and FNAL 3.9 GHz cavities there was no evidence of this multipactor as a cyclotron frequency that high would require a much higher magnetic field beyond the limit of most SRF cavities.

It is well known that in waveguides, grooves can alter the behaviour of multipactor and suppress certain bands. Simulations using Track 3P at SLAC has shown evidence that placing a groove on the cavity wall around the electric mode can significantly reduce the multipactor in these cavities [10]. The manufacture and processing of this groove in the region of highest surface currents is potentially problematic.

COMPACT CAVITIES

As the crab cavities operate in the fundamental dipole mode they are approximately 30% larger than an accelerating cavity of the same frequency. In addition deflecting and crabbing cavities are often required in locations where there is limited space, such as the interaction region of a collider or in a stack of beam separators in a light source. Reducing the transverse size of the cavity would greatly ease the installation and design of crab cavities and hence a number of exotic compact cavity shapes are under investigation. For example for the LHC luminosity upgrade the preferred operating frequency is 400 MHz of maximum luminosity however the space will only allow a 800 MHz elliptical cavity hence a compact solution is required for Phase II in order to utilise a 400 MHz cavity. The increase in luminosity is between 12% and 43% depending on β^* . Most of these designs are based on the use of a coaxial cavity rather than a pillbox/elliptical type cavity. Another type of compact crab cavity utilises the radial electric field variation of an accelerating mode near the wall.

Four Rod Cavity

Although there have been no SRF compact crab cavities installed in an accelerator there has been successful operation of a compact normal conducting deflecting cavity in CEBAF for the separation of electron beams [12]. This cavity is based upon a parallel bar transmission line enclosed in a stainless steel outer can, where the bars are parallel to both the beam and each other. In order to produce the radial variation of the longitudinal electric field, required for a deflecting field, there is a gap in the centre of the transmission line formed by using four rods attached to the outer can. The capacitive gap between the rods makes the cavity slightly shorter than a half wavelength longitudinally. It is also possible to use a quarter wave version with two bars and a capacitive gap between the bars and the outer can. These cavities have very small transverse dimensions. As most of the electric energy is contained in the centre of the cavity this design has a very high R/Q.

For the LHC luminosity upgrade Phase II an SRF version of this cavity is proposed by the Cockcroft Institute and TJNAF [7]. In order to make the cavity suitable for an SRF construction the inner rods of the cavity must be made thicker to reduce microphonics in the cavity, without reducing the crabbing field. This is performed by using conical rods where the rods are thick near the outer can connections and thin at the tips, shown in Figure 8. In addition as this cavity is for the LHC the spacing between the rods must be increased to allow clearance for the larger LHC beam. As most of the losses occur on the rods the outer can could be made from low RRR Niobium while the rods are made from high RRR Niobium.

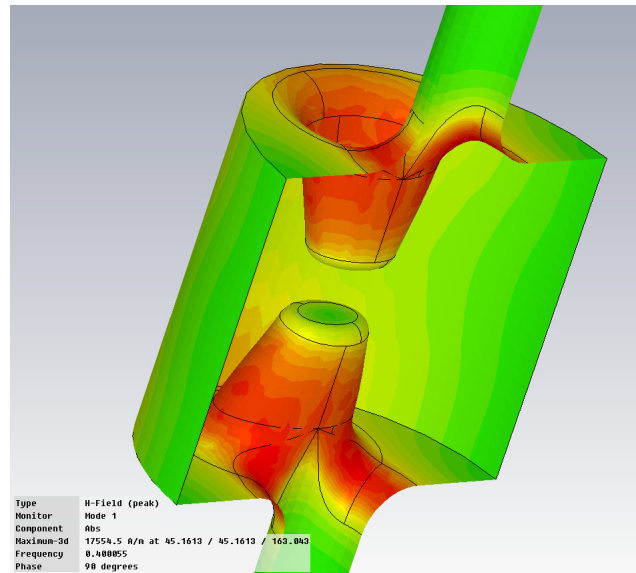

Figure 8: The 4-rod crab cavity design, proposed for the LHC luminosity upgrade, showing the relative magnetic field magnitude simulated in CST- Microwave Studio.

In this cavity the rods provide a natural polarisation as we use a TEM type mode which can only have one polarisation, hence there is no SOM. However the separation between the crabbing mode and a accelerating type mode (similar to the LOM) becomes much closer together as the operating/crabbing mode is a TEM mode supported between the two rods, and the LOM is a TEM mode supported between the inner rods and the outer cans. These modes can be separated with careful optimisation of the capacitive gap between the rods. In order to damp this LOM-like mode we can use either a waveguide or a coaxial line attached to the outer can at the field null of the crabbing mode. The coupling to this mode can be enhanced by using a squashed outer can profile.

Parallel Bar Cavity

Another compact crab cavity based on parallel bar transmission lines is the parallel bar crab cavity designed at TJNAF [13], shown in Figure 9. This design again utilises a pair of parallel bars however this time the bars are parallel to the direction of the beam. As the bars are terminated in a short rather than a capacitive gap, the two rods must be a half wavelength long. A half wave cavity of this design hence has a crabbing field at the centre of the cavity. In addition as the beam-pipe is not in a location of high surface currents this design has a very low surface magnetic field. The peak surface fields can be reduced by tapering the rods near the centre where the electric field is highest. Another possible improvement can be made by bowing the rods such that they are close at the centre and far apart at the connections to the outer can.



Figure 9: The parallel bar crab cavity concept.

A simple multiple cell version has also been proposed by adding a periodic longitudinal array of rods in the outer can. An analytical model of this cavity has been developed that is found to give excellent agreement with simulations due to its simple geometry. Again this cavity does not have a SOM or LOM but does have a degenerate accelerating mode.

Half-wave Resonator

A SLAC design aiming at a half-wave resonator (HWR), typically referred to as quarter-wave resonator (QWR) for the accelerating mode, is proposed for the LHC upgrade Phase II [10]. This design is different from accelerating QWRs as the cavity mode is not a TEM mode but the TE₁₁ mode of the coaxial line. This gives the appearance of a half-wave resonator as there is a quarter wavelength down one side and a quarter wavelength back up the other side, as can be seen in Figure 10. The cell profile is optimised to minimise the electric and magnetic fields. In order to break the symmetry between the operating mode and the SOM, the cell shape is squashed, with the shorter axis in the horizontal plane making the SOM 40 MHz lower in frequency.

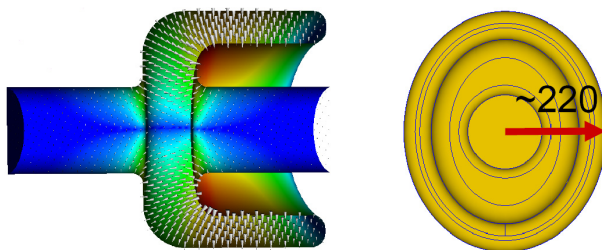

Figure 10: The HWR crab cavity design proposed by SLAC for the LHC Luminosity upgrade.

The SOM and LOM are damped by adding a coaxial probe to the wall at the electric mode of the crabbing mode, and are able to achieve damping to external Q's in

07 Cavity design

the region of 100. This coupler avoids coupling to the crabbing mode via symmetry so again tight tolerances are required. This design would require 3-4 cavities per beam in the LHC due to its low transverse kick.

A similar design is under fabrication for use in RHIC to improve the losses at transition and collision energy operated at TM₀₁₀ mode. It maybe possible to drive this structure when installed in the deflecting mode to probe several issues related to hadron colliders.

Monopole Cavities

It has also been proposed a monopole cavity could be used for crabbing applications. A conventional pill-box structure with offset beam-pipes close to the cavity equator can utilize the kick from the magnetic field of this mode. At the cavity walls the magnetic field is at a maximum and the electric field is zero. However the beam cannot travel along the wall so it has to propagate slightly away from the wall, hence there is a finite longitudinal electric field which will lead to beam-loading and HOM excitation.

A multi-cell version of this was originally proposed as an exotic alternative for the ILC crab cavity but was considered to be less optimal than the 3.9 GHz elliptical design. There is also a BNL proposal to use this type of cavity for the LHC [14], shown in Figure 11. In the BNL scheme the cavity profile would be altered to obtain a maximum magnetic field at the position of the beam-pipes, optimising the kick. The BNL scheme has however not been simulated and is just a concept at present.

The advantage of this scheme is there is no lower order mode and the peak surface fields are much smaller. Also as the beam travels close to the wall the transverse space issues become simpler. Although the concept is conceptually simple and HOM damping relatively simpler compared to the other designs, the large offsets in the cavity may lead to higher order cavity modes to couple to the beam very strongly which is not desired. Additionally, the non-zero longitudinal electric field needs to be compensated. Multipacting needs careful to be evaluated in such a configuration.

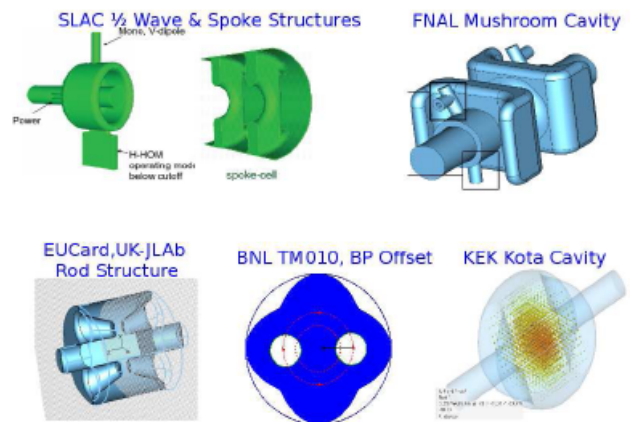

Figure 11: All the compact crab cavity shapes proposed for the LHC luminosity upgrade.

A KEK proposal to use a similar pill-box type structure but with beam-pipes mounted transversely to the cavity as opposed to the nominal pill-box [14], also shown in Figure 11. In a pillbox cavity, if the beam traverses the cavity transversely the beam will experience a kick from both the electric and magnetic fields however they will cancel each other out, as can be seen by Panofsky-Wenzel theorem as there is no transverse varying electric field in the direction of beam propagation. In this configuration the transverse electric field is used to deflect the bunch and special nose cones are required to shield the magnetic field, this also creates a transverse varying longitudinal electric field. The simple shape means the cavity is much easier to process and clean. The cavity also has no lower order mode which will additionally make the damping scheme simpler.

Mushroom Cavity

A similar design to the HWR is the FNAL mushroom type cavity which uses the typical concept of the elliptical cavities but with dramatic bends to reduce the transverse size [14], shown in Figure 11. This is similar to the folded-waveguide concept often used in TWT design. This scheme uses a hollow beam-pipe coaxial line on both beam-pipes for damping the LOM or coax-to-coax couplers for the LOM and HOMs. This structure is also prone to heavy multipacting near the bend regions which need detailed study and a similar structure is under testing but at higher frequencies.

Spoke Resonator

A spoke structure operating in the deflecting mode is also proposed by SLAC as a possible candidate for a compact LHC crab cavity design [14], shown in Figure 11. This design is very similar to the spoke resonators used as accelerating cavities. A minimum iris radius of 60 mm is required for effective cell-to-cell coupling. This structure although mechanically stable has strong multipacting issues and kick gradients are typically smaller than the elliptical counter parts.

CONCLUSION

There are a number of novel cavity concepts for utilisation as crab cavities in accelerators. The designs primarily address the concerns of LOM and SOM damping or cavity transverse size.

The new damping shapes all use either couplers attached directly to the cavity or the use of hollow coaxial beam-pipes. Both of these design concepts bring with them problems in cavity manufacturing and processing which will require further investigation. ANL have constructed a single cell prototype of the on-cell damper which may address some of these issues.

The compact designs are based on TEM mode cavities, folded waveguide or monopole type cavities. These designs are all novel but much can be adapted from the construction of low-beta cavities.

The fact that each accelerator requires a very small numbers of these cavities, and that they are not completely essential components (a collider will still collide albeit at a lower luminosity) allows the designers to attempt brave new concepts that would not be considered for accelerating cavities.

There are also a number of normal conducting shape developments in crab cavities which are not covered in this paper. Specifically there is the H-type deflector developed by FZJ and IHEP [15], and the TE_{11n} deflector proposed by Paramonov [16].

ACKNOWLEDGEMENTS

The author would like to thank all of the Scientists and Engineers involved in the work described here. The author would particularly like to thank Peter McIntosh from STFC, Zenghai Li of SLAC and Haipeng Wang of TJNAF for discussions on the new crab cavity shape developments.

REFERENCES

- [1] R. B. Palmer, Energy scaling, crab crossing and the pair problem SLAC-PUB-4707, 1988
- [2] T. Abe et al, Compensation of the crossing angle with crab cavities at KEKB, MOZAKI01, PAC07, Albuquerque
- [3] W. Bauer et al, RF tests on deflecting cavities for a superconducting particle accelerator, IEEE Transactions on Nuclear Science, 1973
- [4] C. Adolphsen et al, Design of the ILC Crab cavity System, EUROTeV-Report-2007-010
- [5] G. Burt, Analysis of Damping Requirements for Dipole Wake-Fields in RF Crab Cavities, IEEE Trans. Nuc. Sci
- [6] J. Shi, Superconducting RF Deflecting cavity design and prototype for short X-ray pulse generation, EPAC 08
- [7] B. Hall, G. Burt et al, Novel Geometries for the LHC Crab Cavity, TU5PFP040, PAC 09, Vancouver
- [8] K. Akai and Y. Morita, New design of crab cavity for SuperKEKB. PAC 2005
- [9] L. Xiao et al, 800 MHz Crab Cavity conceptual design for the LHC upgrade, SLAC-PAB-13648, 2009
- [10] Z. Li, L. Xiao, A compact alternative crab cavity design at 400 MHz for the LHC upgrade, W5PFP047, PAC 09
- [11] Y. Morita et al, Multipacting in the Crab Cavity,
- [12] C. Leemann & G. Yao "A highly effective Deflecting structure" 1990 Linear Accelerator conference, Albuquerque, New Mexico
- [13] J. R. Delayen and H. Wang, A new compact TEM-type deflecting and crabbing RF structure, PRST-AB 12 062002 (2009)
- [14] I. Ben-zvi et al. LHC Crab Cavities, CARE Workshop 08, CERN Geneva, Dec 2008
- [15] Yu. Senechev, Novel H-type RF deflector, PRST-AB, 9, 012001, 2006
- [16] V. Paramonov, S. Korepanov, effective Standing-wave RF structures for charged-particle deflection, THP034, LINAC 2006